

CATALOGUE DC SWISS SA

КАТАЛОГ DC SWISS SA



Каталог Catalogue

RU-EN-ID TC.1



RU-EN-ID TC.1





Q-TAP



CORONA GEMÄSS
180741 C11815
LITHIUM-IONEN-PAKETE
180760 C11830



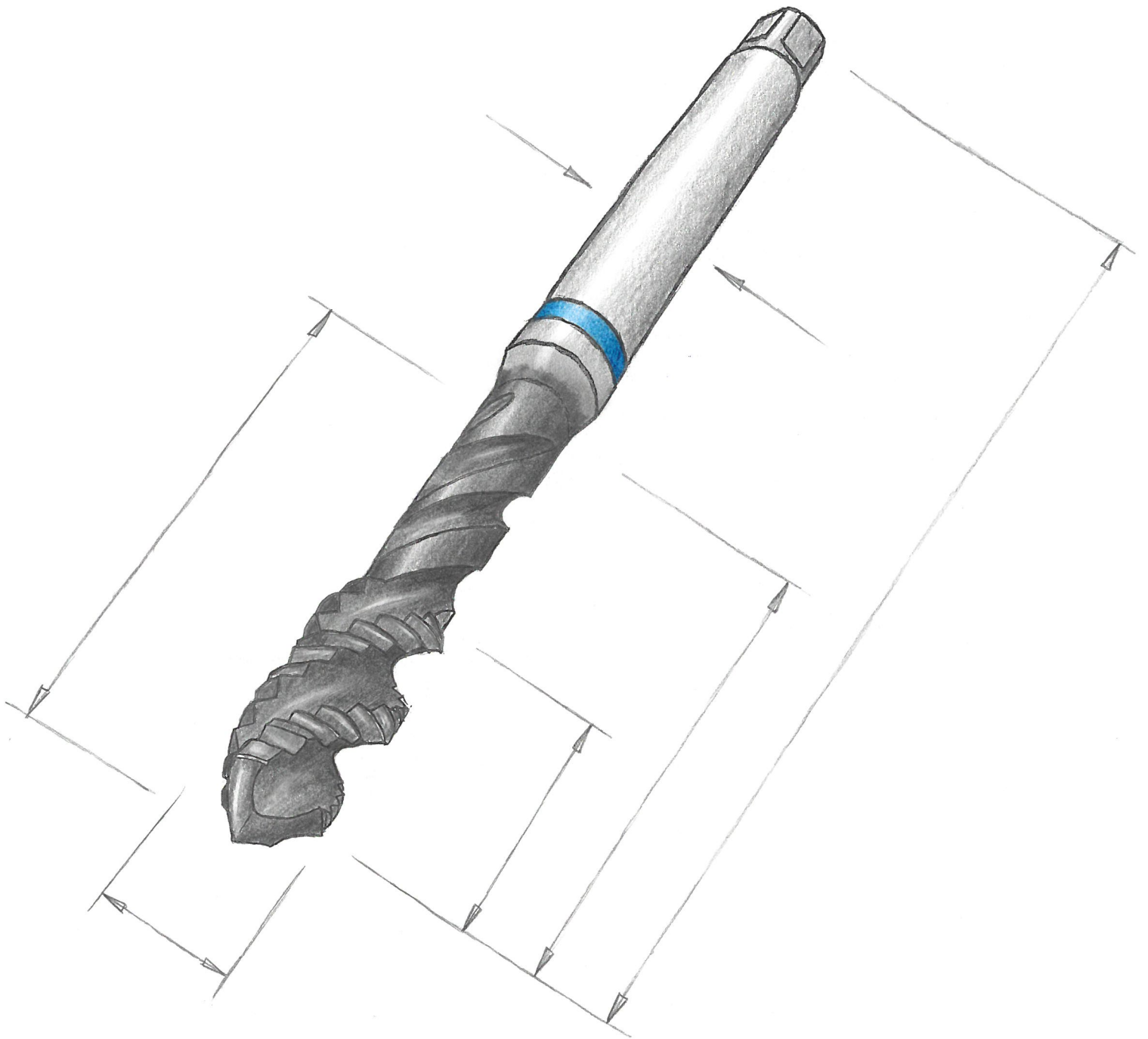



НАЛИЧИЕ ИЗДЕЛИЙ

- ID Складская позиция
- ID Доступно в короткие сроки
- * ID Доступно пока есть на складе

AVAILABILITY OF THE ARTICLES

- ID Stock item
- ID Available at short notice
- * ID Available from stock, while stock lasts



Наш инновационный бизнес находится у себя дома в Бернер-Юра в Швейцарии, идиллически приютившись между холмами и на берегах еще молодой реки Бирс. Именно здесь с 1940 года разрабатываются, производятся и поставляются по всему миру высокопроизводительные резбонарезные инструменты под брендом DC.

С момента основания компании мы сосредоточились на расширении нашего ассортимента метчиков HSSE / HSSE-PM и раскатников для оптимального удовлетворения потребностей наших клиентов и на постоянном развитии новых типов инструментов для новейших технологий и материалов.

В 2000 году мы создали новое производственное подразделение "ONE STEP", оснащенное новейшими производственными технологиями, для разработки и изготовления надежных и мощных твердосплавных резбовых фрез. В то же время наша программа твердосплавного инструмента была значительно развита и расширена, с акцентом на резбовые микрофрезы.

С 2010 года особое внимание уделяется развитию наших микроинструментов. Результатом этого является очень широкая программа "Нано", которая включает в себя микрофрезы, метчики, раскатники, резбовые калибры и контр-калибры в диапазоне диаметров от 0.3 - 2.75 мм. Как компания, аккредитованная согласно ISO 17025:2017, DC Nano Tools SA является специалистом в этой области.

Сегодня наши высокопроизводительные резбонарезные инструменты используются во всем мире и во всех отраслях промышленности, где **качество, производительность и надежность** продукции имеют первостепенное значение.

Если вы не найдете то, что вам нужно в нашем широком ассортименте стандартных изделий, мы можем модифицировать инструменты в соответствии с вашими потребностями или изготовить специальные изделия, основанные на ваших спецификациях и чертежах.

Что касается вопросов, на которые вы не можете найти ответа в нашем каталоге, то мы, конечно же, всегда к вашим услугам.



**"Вначале я искал самые лучшие инструменты,
а потом решил изготовить их сам"**

Даниел Шарпиллоз -1940



Our innovative SME is at home in the Berner Jura in Switzerland, idyllically nestled between hills and on the banks of the still young river called Birs. This is where since 1940 the high-performance threading tools of our brand DC are developed, manufactured and supplied all over the world.

Since the foundation of our company, we have focused on expanding our range of HSSE / HSSE-PM taps and thread formers in order to optimally meet our customers' needs and on constantly developing new tool types for the latest technologies and materials.

In 2000, we created the new "ONE STEP" production division, equipped with the latest production technologies, for the development and manufacture of reliable and powerful solid carbide thread milling cutters. In the meantime, our CAR programme has been greatly developed and expanded, with a focus on thread whirling cutters.

Since 2010, special attention has been paid to the development of our micro tools. The result is our in the meantime really broad "nano" programme, which includes thread whirlers, taps, thread formers, thread gauges and check thread gauges in the diameter range from 0.3 - 2.75 mm. As an ISO 17025:2017 accredited company, DC Nano Tools SA is your specialist in this field.

Today, our high performance threading tools are used worldwide and in all industries where **quality, performance** and **reliability** of the products are paramount.

If you do not find what you need in our wide range of standard products, we can modify tools to suit your needs or manufacture specific special items, based on your specifications and drawings.

For questions, to which you cannot find an answer in our catalogue, we are of course gladly at your entire disposal.



"In the beginning, I was looking for the best tools, then I decided to produce them myself"

Daniel Charpilloz – 1940

DC SWISS ВО ВСЕМ МИРЕ

И ВСЕГДА РЯДОМ С ВАМИ



БЛИЗОСТЬ К КЛИЕНТУ

Вы всегда найдете компетентного сотрудника для контакта, будь то на нашем главном сайте в Швейцарии, в одном из наших филиалов в Германии, Италии и Англии или в одном из наших многочисленных представительств или у диллеров по всему миру.

CUSTOMER PROXIMITY

You will always find a competent contact person, whether at our main site in Switzerland, at one of our subsidiaries in Germany, Italy and England, or at one of our many representatives or resellers worldwide.

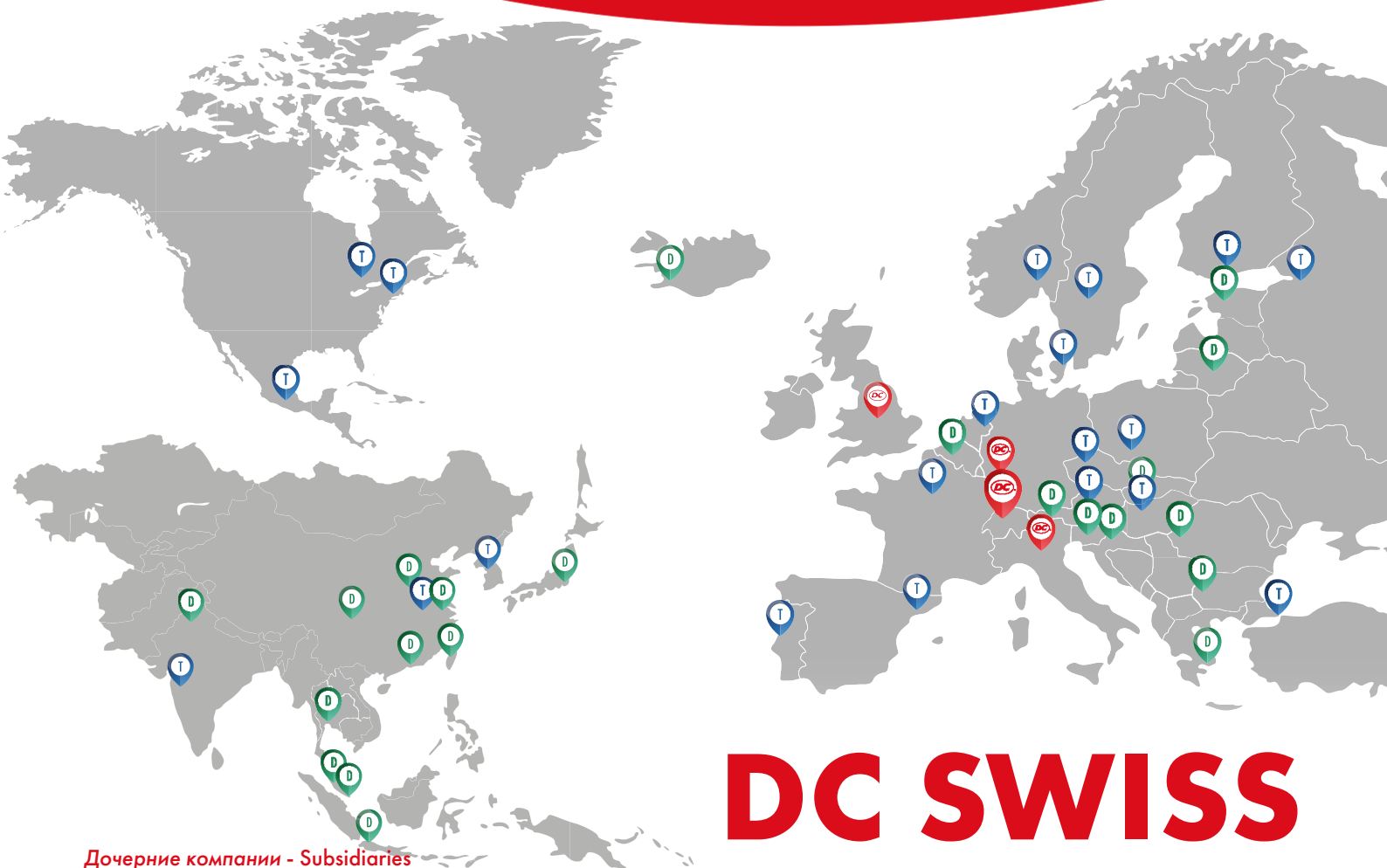

Дочерние компании - Subsidiaries
Технологические партнеры - Technology Partners
Дистрибьюторы - Distributors

Для остальных стран: dcswiss.com/ru/сеть-продаж
For further countries: dcswiss.com/en/sales-network

DC SWISS WORLDWIDE

AND ALWAYS CLOSE TO YOU

SWISS QUALITY

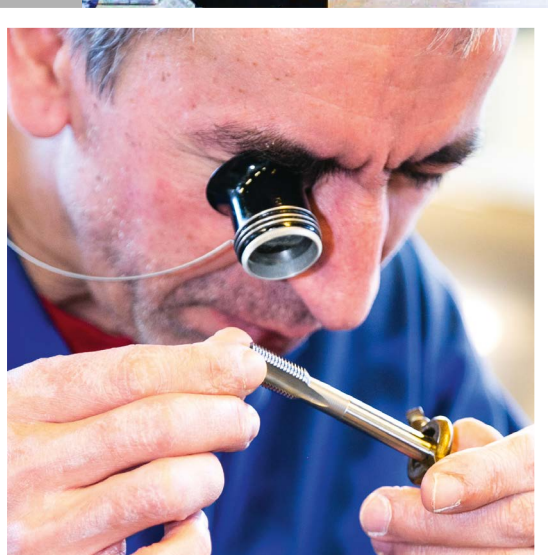

**100 % сделано
компанией DC SWISS -**

гарантировано начиная от разработки инструмента до его производства и вплоть до конечного контроля, благодаря нашим ноу-хау и компетентности во всей области производства резьбонарезных инструментов.

100 % made by DC SWISS - guaranteed from the development of the tool to its production and straight through to the end control, thanks to our know-how and competencies in the whole field of threading tool manufacturing.

НАШИ ЦЕННОСТИ

ПРОИЗВОДИТЕЛЬНОСТЬ

Мы прилагаем все усилия для разработки новых высокопроизводительных резбонарезных инструментов и адаптации производительности наших стандартных инструментов к текущим потребностям наших клиентов. Мы придаем большое значение постоянному соотношению цена / качество как основе доверительных отношений с нашими клиентами.

OUR VALUES

PERFORMANCE

We make every effort to develop new high-performance threading tools and to adapt the performance of our standard tools to the current needs of our customers. We attach great importance to a constant price/performance ratio as the basis for a trusting relationship with our customers.



АВТОМОБИЛЬНАЯ
AUTOMOTIVE

ЧАСОВАЯ
WATCHMAKING

АЭРОКОСМИЧЕСКАЯ
AEROSPACE

МЕДИЦИНСКАЯ
MEDICAL

ИНДИВИДУАЛЬНЫЕ РЕШЕНИЯ
CUSTOMISED SOLUTIONS



НОУ-ХАУ

Ценность нашего ноу-хау заключается в уникальном способе решения проблем и формулирует, реализует и связывает все знания, опыт и способности, накопленные с 1940 года.

KNOW-HOW

The value of our know-how represents in a unique way the solving of problems and articulates, implements and associates the whole knowledge, experiences and competences accumulated since 1940.

НАДЕЖНОСТЬ

Мы знаем, что прочные отношения могут быть построены только на основе доверия, прозрачности и ежедневных усилий каждого из наших сотрудников по предоставлению нашим клиентам инструментов и услуг отличного качества.

RELIABILITY

We know that lasting relationships can only be built on the basic of confidence, transparency and the daily efforts of each of our employees to provide our customers with tools and services of an excellent quality.



ПРОФИЛЬ КОМПАНИИ

ОБУЧАЮЩАЯ КОМПАНИЯ

DC SWISS SA активно участвует в обучении молодежи и дальнейшем совершенствовании уже опытных специалистов. Как обладатели звания "**обучающая компания**", мы считаем делом чести каждый год обучать новых стажеров.

Для нас важно обеспечить следующее поколение профессионалов и предложить им возможности для развития и дальнейшего обучения в области с высоким потенциалом.



COMPANY PROFILE

TRAINING COMPANY

DC SWISS SA is actively involved in the training of young people and the further education of already experienced professionals. As holder of the "**Training company**" label, it is a matter of honour for us to train new apprentices every year.

It is important to us to ensure the next generation of professionals and to offer them opportunities for development and further training in a field with high potential.



Filière
de formation
POLYMÉCANICIEN

Мы также являемся участником программы политехнического ученичества - сети из 6 компаний, целью которой является обучение стажёров -политехников.

We are also a member of the polymechanic apprenticeship programme; a network of 6 companies whose aim is to train polymechanic apprentices.



FCC Полимеханик - Polymechanic FCC

FCC Производственный механик - Production mechanic FCC

FCC Специалист по логистике - Logistics specialist FCC

FCC Коммерческий специалист - Commercial employee FCC

FCC = Федеральный Сертификат Квалификации

FCC = Federal Certificate of Competence



Сокращение выбросов CO2
и повышение энергоэффективности
Reducing our CO2 emissions
and improving our energy efficiency



Мы выступаем за использование переработанных
или **перерабатываемых материалов**
We favour the use of **recycled**
or **recyclable materials**



Сортировка отходов
Sorting our waste

ОХРАНА

ОКРУЖАЮЩЕЙ СРЕДЫ

Мы активно стремимся защищать окружающую среду и климат, сокращать потребление воды и электроэнергии и ограничивать деловые поездки наших сотрудников только самым необходимым. При этом мы очень ответственно используем ресурсы.

PROTECTION OF THE ENVIRONMENT

We are actively committed to protecting the environment and the climate, to reducing our consumption of water and electricity and to limiting the business travel of our employees to the bare essentials. In doing so, we use resources in a highly responsible manner.



Знаете ли вы что DC Swiss AG
заключила соглашение с энергетическим
агентством по экономике и Швейцарской
Конфедерацией?

Did you know that DC SWISS SA
has concluded an agreement with the
Energy Agency for the Economy and the
Swiss Confederation?

A close-up photograph of a silver-colored metal drill bit with a blue band near the handle and a black cutting edge. The background is a blurred array of similar drill bits.

НАРЕЗАНИЕ РЕЗЬБЫ
THREAD CUTTING

A close-up photograph of a silver-colored metal tool with a threaded section and a pointed tip. The background is a blurred array of similar tools.

ОБРАЗОВАНИЕ РАСКАТНИКАМИ
THREAD FORMING

A photograph of a large, complex aircraft engine with a blue and white color scheme, mounted on a stand.

АЭРОКОСМИЧЕСКАЯ
AEROSPACE

A close-up photograph of a silver-colored metal tool with a complex, multi-fluted cutting edge. The background is a blurred array of similar tools.

ФРЕЗЕРОВАНИЕ РЕЗЬБЫ
THREAD MILLING

A photograph of a car body on an assembly line, with a red robotic arm positioned above it.

АВТОМОБИЛЬНАЯ
AUTOMOTIVE

A photograph of a medical device, possibly a surgical instrument or diagnostic equipment, in a clinical setting.

МЕДИЦИНСКАЯ
MEDICAL

A photograph of a complex, multi-faceted metal mechanical part with various holes and features.

ИНДИВИДУАЛЬНЫЕ РЕШЕНИЯ
CUSTOMISED SOLUTIONS

**ЭНЕРГЕТИЧЕСКАЯ
POWER GENERATION**



**ЧАСОВАЯ
WATCHMAKING**



**ОБЩЕЕ МАШИНОСТРОЕНИЕ
GENERAL ENGINEERING**



**ФРЕЗЕРОВАНИЕ РЕЗЬБЫ МИКРОФРЕЗАМИ
THREAD WHIRLING**



**РЕЗЬБОВЫЕ КАЛИБРЫ
THREAD GAUGES**



**РЕЗЬБОНАРЕЗНЫЕ ПАТРОНЫ
TAPPING CHUCKS**



**ПЛАШКИ
DIES**



НАШ ОПЫТ

КАЛИБРОВОЧНЫЙ И МЕТРОЛОГИЧЕСКИЙ СЕРВИС

DC SWISS имеет метрологическую лабораторию, которая аккредитована швейцарской службой аккредитации в качестве лаборатории для калибровки длин.

Компания DC SWISS может предложить услуги по калибровке и метрологии винтовых соединений.

Сертификат-это письменное подтверждение качества метрологического оборудования предприятия. DC NANO TOOLS SA (SCS аккредитация 0143), входящая в группу DC SWISS Group, может проверять и калибровать резьбовые калибры-пробки, а также резьбовые калибры-кольца в соответствии с международным стандартом ISO 17025.

Наши инструменты являются результатом многочисленных исследований. Мы проектируем их, используя все знания, которые мы приобрели за многие годы, всегда проверяя их до пределов возможного. Мы делимся с вами всеми этими знаниями в форме наших услуг. Наша цель состоит в том, чтобы обеспечить наиболее подходящее решение в каждом конкретном случае, начиная с технико-экономического обоснования и заканчивая массовым производством.

Мы являемся экспертами во всех аспектах процесса нарезания винтовой резьбы и можем предложить вам наш комплексный опыт от проектирования, механической обработки и метрологического контроля до различных этапов создания винтовых соединений.

Опыт проектирования

Каждый дизайн уникален, но часто существует несколько решений. Мы можем посоветовать вам, какой тип крепления винта выбрать, например, регулируемые, самоблокирующиеся или высококачественные винты. На этапе проектирования мы можем помочь вашим проектировщикам определить и решить наиболее эффективные варианты крепления винтов с точки зрения размеров, практичности, производственных затрат и сборки.

Опыт механической обработки

Каждый инструмент требует специального программирования, включающего множество параметров. Мы можем помочь вам получить лучшее от ваших машин и инструментов, чтобы достичь максимальной производительности с помощью персонализированного программирования. Мы можем предоставить вам поддержку на этапе проверки и измерения, так что вы можете быть уверены в том, что произвели резьбу винта, которую вы ожидали. И если инструмент нужно подгонять, то мы можем сделать это так, что он будет отвечать всем вашим требованиям. Часто конкретный подход к подгонке позволяет решить проблему, вызванную сложной геометрией или необычным позиционированием.

Метрологическая экспертиза

Мы поставляем большое количество измерительных приборов, а также советы по их использованию и проверке, чтобы обеспечить постоянное достижение требуемого качества. Существуют и другие более конкретные измерения, такие как измерения концентричности и сертификация. Мы можем помочь вам в настройке контрольных процедур. Эта услуга доступна для диаметров шага от 0.1 до 3.0 мм и наружных диаметров от 0.1 до 3.5 мм. Не рискуйте - воспользуйтесь опытом компании DC NANOTOOLS SA для калибровки ваших измерительных инструментов.

Обучение

В нашем прикладном центре и нашей лаборатории мы распространяем полную информацию и рекомендации по передовой практике для всех наших клиентов в области проектирования, производства и использования винтовых креплений. Мы можем обеспечить по требованию обучение по конкретным предметам, таким как безопасные крепления.

OUR EXPERTISE

CALIBRATION & METROLOGY SERVICE

DC SWISS has a metrology lab that is accredited by the Swiss Accreditation Service as a laboratory for calibrating lengths.

DC SWISS is able to offer a calibration and metrology service for screw connections.

A certificate is written confirmation of the quality of a company's metrological equipment. DC NANO TOOLS SA (SCS accreditation 0143), a member of the DC SWISS Group, can inspect and calibrate thread plug gauges as well as thread ring gauges in accordance with the ISO 17025 international standard.

Our tools are the result of numerous studies. We design them using all the knowledge we have acquired over many years, always testing them to their utmost limits. We share all this knowledge with you in the form of our services. Our aim is to provide the most appropriate solution in each case, from feasibility study right through to mass production.

We are experts in all aspects of the process of screw threading, and are able to offer you our assembly expertise from design, machining and metrological inspection through the various stages of creating screw connections.

Design expertise

Each design is unique, but there are often multiple solutions. We can advise you on which type of screw fixing to choose, for example adjustable, self-locking or high-quality screws. During the design phase, we can help your designers to identify and decide the best-performing screw fixing in terms of dimensions, practicality, production costs and assembly.

Machining expertise

Each tool calls for special programming involving numerous parameters. We can help you to get the best out of your machines and tools in order to achieve maximum performance via personalised programming. We can provide you with support in the inspection and measurement phase, so you can be sure of having produced the screw thread you were expecting. And if a tool needs to be customised, we can do this so that it meets all your requirements. Often, a particular approach to fitting makes it possible to resolve a problem caused by complex geometry or unusual positioning.

Metrological expertise

We supply a large number of measuring gauges and also advice on how to use and inspect them in order to ensure the required quality is consistently achieved. Other more specific measures are available, such as concentricity and certification measures. We can assist you in setting up control procedures. This service is available for pitch diameters of 0.1 to 3.0 mm, and external diameters of 0.1 to 3.5 mm. Don't take the risk – benefit from the expertise of DC NANO TOOLS SA to calibrate your measuring tools.

Training

In our application centre and our laboratory, we distribute full information and advice on best practice to all our customers in the design, manufacture and use of screw fixings. We can provide on-demand training in specific subjects such as secure fixings.



ПРОФИЛЬ КОМПАНИИ

СЕРТИФИКАТ ISO 9001

Все направления деятельности компании сертифицированы по стандарту ISO 9001 с 2006 года.



COMPANY PROFILE

ISO 9001 CERTIFICATION

All areas of the company have been ISO 9001 certified since 2006.

- ✓ *Постоянное повышение удовлетворенности и лояльности клиентов.*
Continuous improvement of customer satisfaction and loyalty.
- ✓ *Соблюдение стандартов продукции в наших процессах и процедурах и оптимизация наших процессов и процедур.*
Adherence to product standards in our processes and procedures and their optimisation.
- ✓ *Снижение затрат, связанных с качеством (отбраковка, исправления и т. д.).*
Reduction of quality-related costs (rejects, retouching, etc.).
- ✓ *Повышение организационной и структурной эффективности.*
Improvement of organisational and structural efficiency.
- ✓ *Повышенная способность адаптироваться к изменениям.*
Increased ability to adapt to change.
- ✓ *Вовлечение персонала в процесс непрерывного совершенствования.*
Involving staff in the continuous improvement process.

Certificate CH07/0649

The management system of

DC Swiss SA

CP 363,
Grand rue 19
CH - 2735 Malleray



has been assessed and certified as meeting the requirements of

ISO 9001:2015

For the following activities

**Design, development, manufacturing, marketing, sales and distribution
of cutting tools. Expertise in threading technology.**

This certificate is valid from 19 June 2018 until 18 June 2021
and remains valid subject to satisfactory surveillance audits
Recertification audit due before 7 June 2021
Issue 6. Certified since September 2007

Authorised by



SGS Société Générale de Surveillance SA
Technoparkstrasse 1 8005 Zurich Switzerland
t +41 (0)44 445-16-80 f +41 (0)44 445-16-88 www.sgs.com

Page 1 of 1

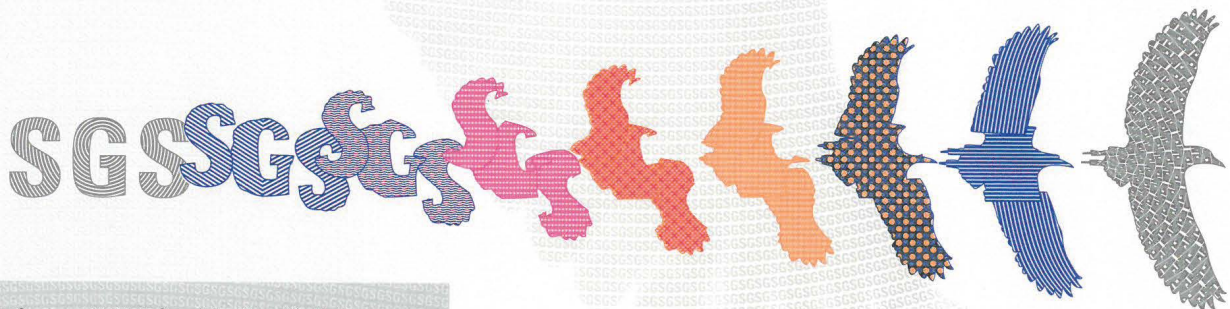

ОБЩИЕ РАЗМЕРЫ В СООТВЕТСТВИИ С ISO / DIN GENERAL DIMENSIONS ACCORDING TO ISO / DIN



N1120-4 ISO 529

Короткий, усиленный хвостовик ISO — Short, reinforced ISO shank



N1220-4 ISO 529

Короткий, утонченный хвостовик ISO — Short, reduced ISO shank



N320-4 DIN 371

Усиленный хвостовик DIN — Reinforced DIN shank



N420-4 DIN 376 / DIN 374

Утонченный хвостовик DIN — Reduced DIN shank



N520-4 NORM DC

Удлиненный машинный метчик с усиленным DIN-хвостовиком; общая длина в соответствии со стандартами DC — Extra long machine tap with reinforced DIN shank; total length as per DC standards



Удлиненный машинный метчик с утонченным DIN-хвостовиком; общая длина в соответствии со стандартами DC — Extra long machine tap with reduced DIN shank; total length as per DC standards

ИЗМЕРЕНИЯ МЕТЧИКА — MEASUREMENTS OF THE TAP

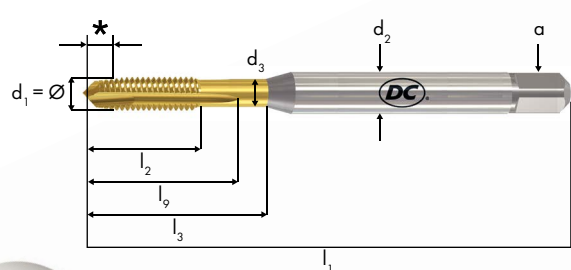







*	Длина заходной части	Chamfer lead length
d₁	Номинальный диаметр резьбы	Nominal thread diameter
d₂	Диаметр хвостовика	Shank diameter
d₃	Диаметр шейки	Neck diameter
l₁	Общая длина	Overall length
l₂	Рабочая часть	Thread length
l₃	Полезная длина	Usable length
l_φ	Длина канавки	Flute length
a	Квадрат	Square
Z	Количество канавок	Number of flutes



Зуб
Lip

Канавка
Flute

ЦЕНТРОВЫЕ КОНУСЫ — CENTER POINTS







	Резьба	Thread
	Полный наружный центровой конус	Full external center point
	Уменьшенный центровой конус	Reduced center point
	Внутренний центровой конус	Internal center point
	Хвостовик	Shank
	Полный наружный центровой конус	Full external center point
	Центровой конус	Centering bevel
	Внутренний центровой конус	Internal center point

Форма центра зависит от диаметра резьбы, типа инструмента и станка, на котором изготавливаются инструменты.

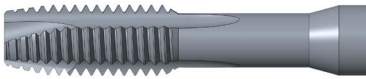
The center shape depends on the thread diameter, the type of tool and the machine on which the tools are manufactured.

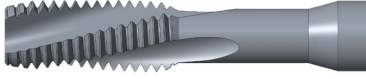
ФОРМЫ КАНАВОК НА МЕТЧИКАХ DC

FLUTE FORMS FOR DC TAPS

	Примеры для правой резьбы	Examples for right-hand threads
	.10 Прямые канавки для сквозных и глухих отверстий в короткостружечных материалах	Straight flutes for through and blind holes in short-chipping materials
	.20 Прямые канавки с подточкой центра для сквозных отверстий в длинностружечных материалах	Straight flutes with spiral point for through holes in long-chipping materials
	.30 Подточка центра для сквозных отверстий в длинностружечных материалах, с глубиной резьбы $\leq 1.5 \times D$; листового металла	Spiral point only for through holes in long-chipping materials, for threading depth $\leq 1.5 \times D$; sheet metal working
	.40 Левые спиральные канавки для сквозных отверстий	Slow left-hand spiral flutes for through holes
	.50 $\leq 27^\circ$ правые спиральные канавки для сквозных и глухих отверстий в короткостружечных материалах $\leq 2.5 \times D$, а также для глухих отверстий в длинностружечных материалах $\leq 1.5 \times D$	$\leq 27^\circ$ slow right-hand spiral flutes for through and blind holes in short-chipping materials $\leq 2.5 \times D$ respectively for blind holes in middle-long and long-chipping materials $\leq 1.5 \times D$
	.60 $> 27^\circ - \leq 40^\circ$ правые спиральные канавки для глухих отверстий в длинностружечных материалах $\leq 2.5 \times D$	$> 27^\circ - \leq 40^\circ$ fast right-hand spiral flutes for blind holes in long-chipping materials $\leq 2.5 \times D$
	.70 $> 40^\circ$ правые спиральные канавки (R45) для глухих отверстий до $3 \times D$ в вязких материалах	$> 40^\circ$ fast right-hand spiral flutes (R45) for blind holes up to $3 \times D$ in tough materials

ФОРМЫ КАНАВОК ДЛЯ СМАЗКИ В РАСКАТНИКАХ DC

LUBRICATION GROOVE FORMS FOR DC THREAD FORMERS



.80

Без канавок для смазки

Without lubrication grooves



.81

С канавками для смазки

With lubrication grooves



.84

С канавками для смазки и
внутренним каналом подвода
СОЖ с боковым 45° выходом
СОЖ (переход на эту новую версию
в процессе)

With lubrication grooves and
internal cooling channel with
lateral 45° lubricant outflow
(conversion to this new version in
progress)

ФОРМЫ ЗАХОДНОЙ ЧАСТИ МЕТЧИКОВ И РАСКАТНИКОВ DC CHAMFER FORMS FOR DC TAPS AND THREAD FORMERS

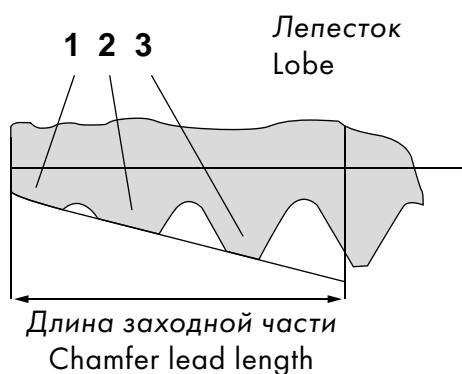

Образование стружки в фаске
Chip formation in the chamfer

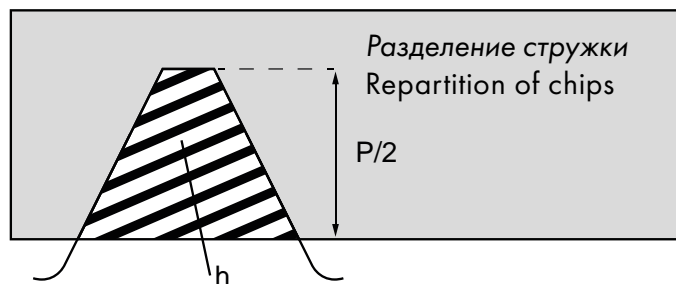

h = толщина стружки
h = Thickness of the chip

Диаметр отверстия под резьбу
Core hole diameter

Форма и длина заходной части метчиков согласно DIN 2197

Chamfer forms and chamfer lead lengths for taps as per DIN 2197

-8		A 8xP	Длина заходной части 6 - 8 ниток; для прямых канавок	Chamfer lead length 6 - 8 threads; for straight flutes
.20 - 4		B 4xP	Длина заходной части 3.5 - 5.5 ниток; для прямых канавок с подточкой центра	Chamfer lead length 3.5 - 5.5 threads; for straight flutes with spiral point
-3		C 2.5xP	Длина заходной части 2 - 3 нитки; для прямых и спиральных канавок	Chamfer lead length 2 - 3 threads; for straight and spiral flutes
-4		D 4xP	Длина заходной части 3.5 - 5 ниток; для прямых и спиральных канавок	Chamfer lead length 3.5 - 5 threads; for straight and spiral flutes
-5		E 1.5xP	Длина заходной части 1.5 - 2 нитки; для прямых и спиральных канавок	Chamfer lead length 1.5 - 2 threads; for straight and spiral flutes

Форма и длина заходной части раскатников согласно DIN 2175

Lead taper forms and lead taper lengths for thread forming taps as per DIN 2175

-3		C 2.5xP	Длина заходной части 2 - 3 нитки	Lead taper length 2 - 3 threads
-5		E 1.5xP	Длина заходной части 1.5 - 2 нитки	Lead taper length 1.5 - 2 threads

ГЕОМЕТРИИ РЕЖУЩЕЙ КРОМКИ DC — DC CUTTING GEOMETRIES

N



Для нормальных материалов
(автоматные стали; структурные, цементуемые; углеродистые стали; легированные < 850 Н/мм²; легко обрабатываемые нержавеющие стали; чугуны с шаровидным графитом и ковкий; латунь с длинной стружкой; сплавы алюминия Si < 10 %)

For normal materials
(free-cutting steels; structural, cementation steels; carbon steels; alloy steels < 850 N/mm²; free machining stainless steels; spheroidal graphite + malleable cast iron; long chip brass; Al alloyed Si < 10 %)

W



Для мягких материалов
(алюминий нелегированный; низколегированный алюминий; термопластики)

For soft materials
(aluminium unalloyed; low-alloyed aluminium; thermoplastics)

Z



Для вязких материалов
(аустенитные нержавеющие стали; ферритные и мартенситные < 850 Н/мм²; чистый титан; никелевые сплавы 1 < 850 Н/мм²; чистая медь)

For tough materials
(rust and acid resistant materials - austenitic stainless steels; ferritic and martensitic < 850 N/mm²; pure titanium; nickel alloys 1 < 850 N/mm²; pure copper)

**ZX
NEW**



Для сплавов алюминиевой бронзы
(AMPCO® 21 / 22)

For ALU-BRONZE-Alloys
(AMPCO® 21 / 22)

H



Для высокопрочных материалов > 850 - < 1'400 Н/мм²
(легированные стали, закаленные стали - высокопрочные легированные стали); **короткостружечная латунь, фосфористая бронза и т.д.); бессвинцовая латунь; дюропластики, стеклопластики**

For high tensile materials > 850 - < 1'400 N/mm²
(alloyed steels, tempered steels - high tensile alloy steels); **short chip brass + phosphor bronze + gun metal; lead-free brass; duroplastics; glass fibre reinforced plastics**

S



Для специальных легированных материалов > 850 - < 1'150 Н/мм²
(легированные стали закаленные; ферритные, мартенситные стали, никелевые сплавы 2)

For special alloyed materials > 850 - < 1'150 N/mm²
(alloy steels hardened / tempered; ferritic, martensitic steels; nickel alloys 2)

**SA AERO
SA.20 / SA.50**



Для специальных легированных материалов > 850 - < 1'150 Н/мм²
(никелевые сплавы, бессвинцовая латунь)

For special alloyed materials > 850 - < 1'150 N/mm²
(nickel alloys 2; lead-free brass)

ГЕОМЕТРИИ РЕЖУЩЕЙ КРОМКИ DC — DC CUTTING GEOMETRIES

SA AERO
SA.90



Для специальных
легированных материалов
> 1'150 - < 1'600 Н/мм²
(никелевые сплавы 3)

For special alloyed materials
> 1'150 - < 1'600 N/mm²
(nickel alloys 3)

TL



Титановые сплавы

For titanium alloys

GG



Для серого чугуна;
алюминиевых отливок с
высоким содержанием Si;
магниевых сплавов

For grey cast iron; aluminium
castings with high Si content;
magnesium alloys

K



Со специальной геометрией
"режущая кромка
стружколома"
(для обычных, легко
обрабатываемых
материалов до 1'150 Н/мм²,
бессвинцовая латунь)

With special "chipbreaker
cutting edge geometry"
(for normal, easily machinable
materials up to 1'150 N/mm²;
lead-free brass)

QTAP
NEW



Универсальный метчик DC
(для обработки широкого
спектра материалов до 1'150
Н/мм², для использования
в резьбовых патронах с
осевой компенсацией и для
синхронного нарезания
резьбы - "Жесткая резьба")

The DC ALLROUNDER
(for machining universal
materials up to 1'150 N/mm²,
for use in tapping chucks with
axial compensation and for
synchronous tapping)

RTS

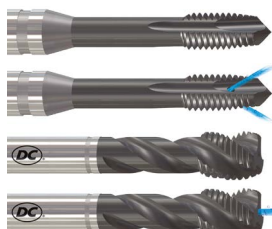

DC Synchro Tap RTS
(для обработки универсальных
материалов до 1'150 Н/мм²,
для синхронного нарезания
резьбы "Жесткое нарезание
резьбы")

DC Synchro tap type RTS
(for machining universal
materials up to 1'150 N/mm²,
for synchronous tapping "Rigid
Tapping")

FS
< Ø 3 mm



Раскатники DC типа FS
(универсальный раскатник
с 4 формообразующими
лепестками для малых размеров
резьбы Ø ≥ 1 - < 3 мм, во всех
деформируемых)

DC Thread formers type FS
(universal thread former with 4
forming lobes for small thread
sizes Ø ≥ 1 - < 3 mm, in all
cold forming materials)

ГЕОМЕТРИИ РЕЖУЩЕЙ КРОМКИ DC — DC CUTTING GEOMETRIES

FPS
≥ Ø 3 mm



Раскатники DC типа FPS
(для Ø ≥ 3 мм, с большими формообразующими лепестками) для обработки материалов с низким коэффициентом удлинения (конструкционные стали, углеродистые стали, легированные стали, длинностружечная латунь, алюминия и др.)

DC Thread formers type FPS
(for Ø ≥ 3 mm, with large forming lobes designed for a progressive flow of materials with low elongation coefficient (structural steels, carbon steels, alloy steels, long chipping brass, aluminium, etc.))

FAS
≥ Ø 3 mm

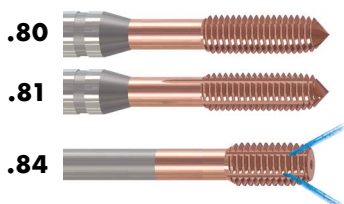

Раскатники DC типа FAS
(для Ø ≥ 3 мм, с заостренными формообразующими лепестками, для материалов с высоким коэффициентом удлинения (нержавеющая сталь, чистая медь и др.))

DC Thread formers type FAS
(for Ø ≥ 3 mm, with pointed forming lobes designed for a fast flow of tough materials with high elongation coefficient (stainless steels, pure copper, etc.))



.21 / .61



Шахматный зуб
(для меньшего тепловыделения)

Interrupted thread
(for less heat generation)



.62



Усеченная резьба
(во избежание заклинивания стружки и поломки зубьев в направляющей части метчика)

Truncated thread
(to avoid chip jamming and tooth breakage in the guiding section of the tap)



.65



Усеченная резьба и внутренний подвод СОЖ с фронтальным выходом

Truncated thread and internal coolant with frontal outflow

ВИДЫ ПОКРЫТИЙ И ОБРАБОТКИ ПОВЕРХНОСТЕЙ ДЛЯ МЕТЧИКОВ И РАСКАТНИКОВ DC – SURFACE TREATMENTS AND COATINGS



V

DC "V" обработка поверхности Обработка паром

Обработка поверхности "V" улучшает трение скольжения и предотвращает холодную сварку (налипание металла)

DC "V" surface treatment Steam tempered

The DC "V" surface treatment improves the sliding friction of the tap and prevents cold welding.



NV

Плазменное азотирование + обработка поверхности "V"

Плазменно-азотированные метчики имеют повышенную поверхностную твердость около 1100 HV и хорошо подходят для обработки абразивных материалов (серого чугуна, литого алюминия с высоким содержанием Si). Они также обладают улучшенными скользящими свойствами благодаря дополнительной обработке поверхности "V".

Plasma nitriding + "V" surface treatment

Plasma-nitrided taps have increased surface hardness, approx. 1100 HV, and are particularly suitable for machining abrasive materials (grey cast iron, cast aluminium with high Si content). They also have improved sliding properties thanks to the additional DC "V" surface treatment.



DLC

Покрытие DLC

Инструменты с DLC-покрытием имеют поверхностную твердость около 2500 HV и особенно подходят для обработки цветных металлов и алюминия с низким содержанием кремния (< 9% Si).

DLC-coating

DLC-coated threading tools have a surface hardness of approx. 2500 HV and are particularly suitable for machining non-ferrous metals and aluminium with a low silicon content (< 9 % Si).



TiN

Покрытие нитридом титана (TiN)

Покрытие из нитрида титана выполнено из твердого металлического материала (ПВД) с твердостью около 2400 HV. Метчики с TiN покрытием особенно подходят для обработки абразивных и налипающих материалов; более высокие скорости резания и улучшенные эксплуатационные характеристики.

Titanium-nitride coating (TiN)

The titanium nitride coating is of a hard metal material (PVD) with a hardness of approximately 2400 HV. TiN-coated taps are particularly suitable for working abrasive and cold-welding type materials; higher cutting speeds and improved performance.



TiCN

Покрытие карбонитридом титана TiCN

TiCN-покрытие с твердостью около 3000 HV даже тверже, чем TiN покрытие, для еще более высоких скоростей резания.

Titanium-carbonitride coating (TiCN)

The TiCN-coating with a hardness of approx. 3000 HV is even harder than the TiN-coating, for even higher cutting speeds.

ВИДЫ ПОКРЫТИЙ И ОБРАБОТКИ ПОВЕРХНОСТЕЙ ДЛЯ МЕТЧИКОВ И РАСКАТНИКОВ DC — SURFACE TREATMENTS AND COATINGS



VS

DC износостойкое покрытие "VS" общего назначения

Специальная обработка для метчиков, специально предназначенных для использования по нержавеющей стали группы "Z" с эмульсией; по особым сплавам группы "S"; и материалам, легированным титаном группы "TL".

DC "VS" wear-protective coating for general use

A special treatment for taps specifically intended for use in Inox with taps of the performance class "Z" with emulsion; in special alloys with taps of the performance class "S"; in titanium alloyed materials with taps of the performance class "TL".



VX

DC износостойкое покрытие "VX" для нержавеющей сталей и никелевых сплавов

Особая обработка поверхности, для метчиков группы "Z", оптимально адаптирована для обработки с эмульсией нержавеющей сталей и никелевых сплавов.

DC "VX" wear-protective coating for stainless steels and nickel alloys

Specific surface treatment, especially suitable for taps in performance class "Z", optimally adapted for machining with emulsion of stainless steels and nickel alloys.

Внимание

Наши стандартные покрытия позволяют выполнять широкий спектр работ. Для конкретных применений в очень специфических материалах мы будем рады предложить вам наиболее подходящее покрытие. Срок поставки и цена по запросу.

Notice

Our standard coatings allow a wide range of materials to be performed. For specific applications in very specific materials, we will be pleased to offer you the most suitable coating. Delivery time and price on request.

NEW

AERO



MJ UNJC - UNJF

S320VS-4



S370VX-3



MJ UNJC - UNJF

SA320-4



SA350-3



SA390-3



MJ UNJC - UNJF

TL351VS-3



ZX



Для АЛЮМИНИЕВЫХ БРОНЗ (AMPCO® 21/22)
For ALU-BRONZE-Alloys (AMPCO® 21/22)

M

ZX320-4

ZX420-4



QTAP



округ Колумбия Алларундер
DC Allrounder

M - MF - UNC UNF - G

Q320VS-4 Q420VS-4



Q323VS-4 Q423VS-4

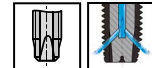

Q360VS-3 Q460VS-3



Q363VS-3 Q463VS-3



РАСШИРЕННАЯ ТАБЛИЦА ПРИМЕНЕНИЯ DC ENLARGED DC APPLICATION CHART

*** 17** **Закалённые легированные стали**
Alloy steels tempered

> 44 - ≤ 54 HRC

*** 18** **Закалённые легированные стали**
Alloy steels hardened

> 54 - ≤ 63 HRC

64 **Латунь бессвинцовая (ECOBASS®)**
Lead free brass (ECOBASS®)

CuZn21Si3P
(ECOBASS®)
CuZn35
CuZn42

* См. нашу программу резьбонарезные фрезы DC-VHM и резбовых микрофрез VHM по каталогу DC TM.1.
* See our programme DC solid carbide thread milling cutters and solid carbide thread whirl cutters as per DC catalogue TM.1.

NEW

RTS



M

7GX

RTS362VS-3

RTS462VS-3



VS

NP



M

NP110-1 NP210-1



NP110-2 -3 NP210-2 -3



H.TC



MF - UNC - UNF

H320TC-4 H420TC-4



TiCN

H350TC-3 H450TC-3



TiCN

ПО ЗАКАЗУ

- Для специфического использования в соответствии с требованиями заказчика:
DC машинные метчики тип MEGA
(Ø 42 - 164 mm)
- Твердосплавные метчики DC для увеличения срока службы и повышения безопасности процесса в конкретных применениях.

ON REQUEST

- For specific applications according to customer requirements:
DC machine taps type MEGA
(Ø 42 - 164 mm)
- DC solid carbide machine taps for higher tool-life and improved process security in specific applications.

ТЕХНИЧЕСКИЕ УЛУЧШЕНИЯ: ПЕРЕХОД НА НОВУЮ ВЕРСИЮ В ПРОЦЕССЕ ПОДГОТОВКИ

TECHNICAL IMPROVEMENTS: CHANGE TO NEW VERSION IN PROGRESS

**ВНУТРЕННИЙ ПОДВОД СОЖ С РАДИАЛЬНЫМ ВЫХОДОМ, НОВЫЙ 45°
INTERNAL COOLANT WITH RADIAL OUTFLOW, NEW 45°**



M

RTS323VS-4 RTS423VS-4

RTS523VS-4 RTS623VS-4

FPS384VS-3 FPS484VS-3

FPS584VS-3 FPS684VS-3

FAS384VS-3 FAS484VS-3

FAS584VS-3 FAS684VS-3



**С НОВОЙ ТЕХНОЛОГИЕЙ ОБРАБОТКИ РЕЖУЩИХ КРОМОК
WITH NEW CONDITIONING OF THE CUTTING EDGES**



**M - MF - UNC - UNF
G - EG UNC - EG UNF**

Z370VS-3 Z470VS-3

M

Z373VS-3 Z473VS-3



**M - MF - UNC - UNF
EG M - EG UNC - EG UNF**

SA320-4 SA420-4

SA350-3 SA450-3

**M - MF - UNC - UNF
EG M - EG UNF**

SA390-3



M

TL320VS-4 TL420VS-4

**M - MF - UNC - UNF
EG M - EG UNC - EG UNF**

TL351VS-3 TL451VS-3

MJ - UNJC - UNJF

S370VX-3 S470VX-3

СКОРО В ПРОГРАММЕ:

Усовершенствованные метчики H.20TC-4 / H.50TC-4
- новое покрытие VH для увеличения срока
службы инструмента до 50%, для материалов по
группам 15 и 16 нашей таблицы применения.

COMING SOON:

Reworked taps H.20TC-4 / H.50TC-3 - new VH
coating to increase tool life by up to 50 %, for
materials according to groups 15 and 16 of our
application chart.

**МЕТЧИКИ NANO, РАСКАТНИКИ, РЕЗЬБОВЫЕ КАЛИБРЫ
NANO TAPS, THREAD FORMERS, THREAD GAUGES**

**M / MF / UNC / UNF
S / SF / SL**

Ø 0.3 - Ø 2.74 mm

DZ04



DZ14



DN01



DN02



TAN

TAZ

FA/CFA

CMS



КОДИРОВКА – CODIFICATION



Пример - Example

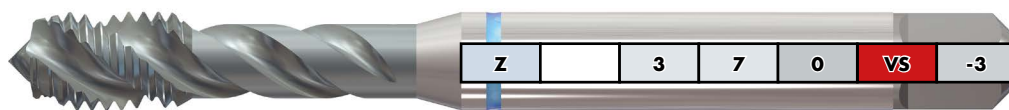

Нормальные материалы	Normal materials		N
Мягкие материалы	Soft materials		W
Вязкие материалы	Tough materials		Z
Алюминиевые бронзы	Alu-bronze alloys		ZX
Материалы с высоким пределом прочности	High tensile materials		H
Специальные сплавы	Special alloys		S
Специальные сплавы (Аэро)	Special alloys (Aero)		SA
Титановые сплавы (Аэро)	Titanium alloys (Aero)		TL
Чугун и алюминиевое литье	Cast iron and aluminium casting		GG
Универсальный метчик	Allrounder		QTAP
Скоростное нарезание резьбы	Rigid Tapping		RTS
Серия "К" для глубоких резьб	Swarf breaker		K
Метчики МЕГА	MEGA tap sizes		MA
Специальное исполнение	Special execution	3	
Короткий усиленный хвостовик по DIN	DIN short - reinforced shank		1
Короткий утонченный хвостовик по DIN	DIN short - reduced shank		2
Длинный усиленный хвостовик по DIN	DIN long - reinforced shank		3
Длинный утонченный хвостовик по DIN	DIN long - reduced shank		4
Сверхдлинный усиленный хвостовик по DIN	DIN extra-long - reinforced shank		5
Сверхдлинный утонченный хвостовик по DIN	DIN extra-long - reduced shank		6
Стандарт DC	DC standards		9
Короткий усиленный хвостовик по ISO	ISO short - reinforced shank		11
Короткий утонченный хвостовик по ISO	ISO short - reduced shank		12
Прямые канавки	Straight flutes		1
Прямые канавки с подточкой центра	Straight flutes with spiral point		2
Подточка центра	Spiral point		3
Левые спиральные канавки < 27°	< 27° left-hand slow spiral flutes		4
Правые спиральные канавки < 27°	< 27° right-hand slow spiral flutes		5
Правые спиральные канавки > 27°	> 27° right-hand fast spiral flutes		6
Правые спиральные канавки > 40°	> 40° right-hand fast spiral flutes		7
10° правые спиральные канавки, подточка центра	10° right-hand slow spiral flutes, spiral point		9
Стандартный	Standard		0
Шахматный метчик	Interrupted thread		1
С увеличенным стружечным пространством	Truncated thread		2
Внутренний подвод охлаждающей жидкости	Internal coolant		3
Шахматный метчик с внутренним подводом СОЖ	Interrupted thread, internal coolant		4
С ув. стружечным пространством и подводом СОЖ	Truncated thread, internal coolant		5
Обработка поверхности "V"	"V" surface treatment		V
DC "VS" износостойкое покрытие общего назначения	VS wear-protective coating, general		VS
DC "VX" износостойкое покрытие для нержавеющей стали	VX coating for stainless steels and Nickel alloys		VX
Покрытие нитридом титана (TiN)	Titanium-nitride coating (TiN)		TN
Покрытие карбонитридом титана (TiCN)	Titanium carbonitride coating (TiCN)		TG
Плазменное азотирование + "V" обработка поверхности	Plasma nitriding + "V" surface treatment		NV
Покрытие DLC	DLC-coating		DL
Предварительный метчик	Taper tap		-1
Второй метчик	Second tap		-2
Чистовой метчик (заходная часть 2 - 3 нитки)	Bottoming tap / 2 - 3 chamfered threads		-3
Заходная часть 3.5 - 5.5 ниток, подточка центра	3.5 - 5.5 chamfered threads, spiral point		-4
Заходная часть 1.5 - 2 нитки	1.5 - 2 chamfered threads		-5
Заходная часть 6 - 8 ниток	6 - 8 chamfered threads		-8
Комплектные метчики	Thread taps set		-S

ПИКТОГРАММЫ — PICTOGRAPHS









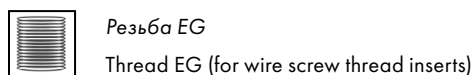
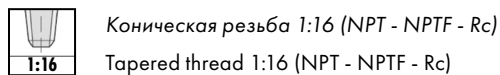
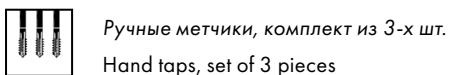
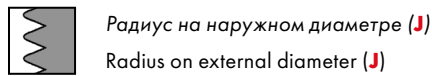
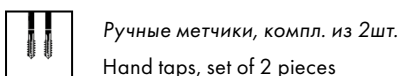
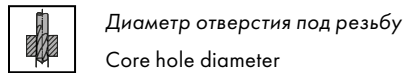
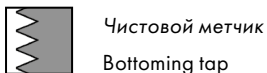
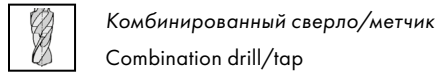
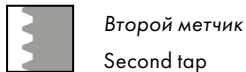
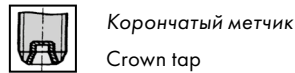
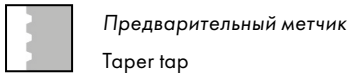
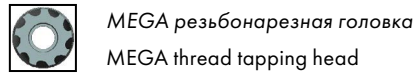
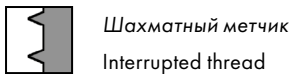
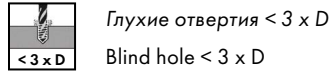
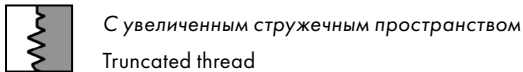
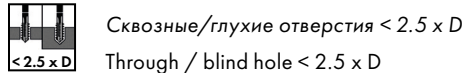
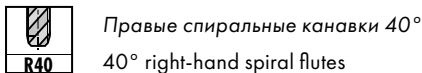
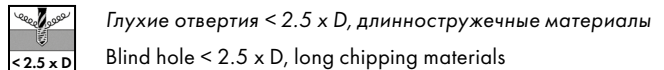
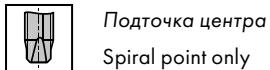
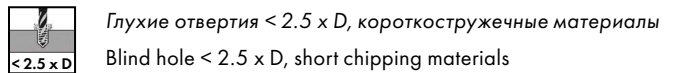
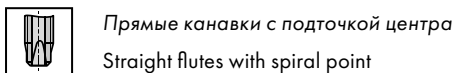
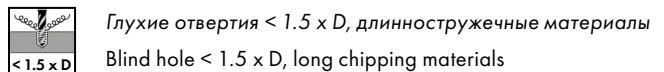
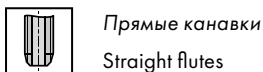
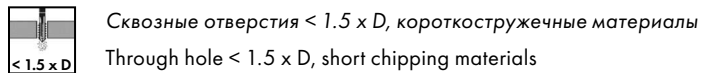
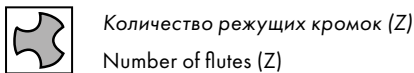
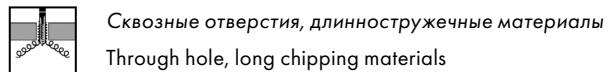
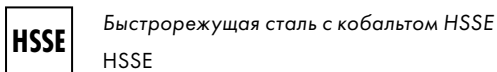
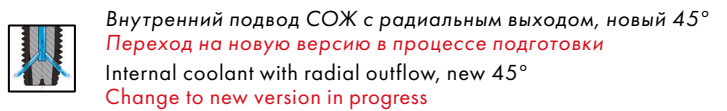
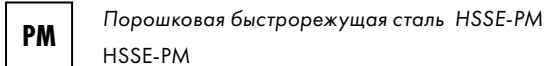
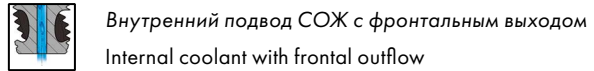
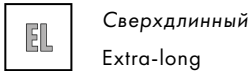
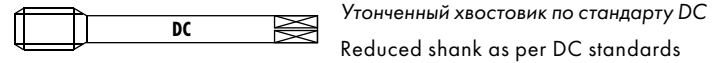
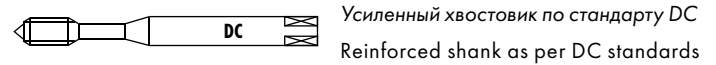











Для групп материалов согласно таблице .
For material groups as per application chart

12	
1.0037	Si37-2 (S235JR)
1.0050	St50-2 (E295)
1.0060	St60-2 (E335)
1.5919	15CrNi6
1.7131	16MnCr5

22	
1.4301	X5CrNi18-10
1.4406	X2CrNiMoN17-12-2
1.4435	X2CrNiMo18-14-3
1.4541	X6CrNiTi18-10
1.4571	X6CrNiMoTi17-12-2



ПИКТОГРАММЫ — PICTOGRAPHS

	Левая резьба Left-hand thread	●	Складская позиция Stock item
	Заходная часть 3.5 - 5.5 нитки, форма B 3.5 - 5.5 chamfered threads, lead form B	●	Доступно в короткие сроки Available at short notice
	Заходная часть 2 - 3 нитки, форма C 2 - 3 chamfered threads, lead form C	*	Доступно пока есть на складе Available from stock, while stock lasts
	Заходная часть 1.5 - 2 нитки, форма E 1.5 - 2 chamfered threads, lead form E		
	Класс точности ISO 2 6H Tolerance class ISO 2 6H		
	Класс точности ISO 2 6H + 0.1 mm Tolerance class ISO 2 6H + 0.1 mm		
	Класс точности ISO 3 6G Tolerance class ISO 3 6G		
	Обработка поверхности "V" DC "V" surface treatment		
	DC "VS" износостойкое покрытие общего назначения DC "VS" wear-protective coating for general use		
	DC "VX" износостойкое покрытие для нержавеющей сталей и сплавов на основе никеля. DC "VX" wear-protective coating for stainless steels and Nickel alloys		
	Покрытие нитридом титана Titanium-nitride coating		
	Покрытие карбонитридом титана Titanium-carbonitride coating		
	Плазменное азотирование + "V" обработка поверхности Plasma nitriding + "V" surface treatment		
	Покрытие DLC DLC-coating		
	Покрытие HADRDLUBE Hardlube-coating		
	Элементная стружка Swarf fragments / consistant chips		
	Для скоростного нарезания For Rigid Tapping		
	Для классического нарезания резьбы For Classic Tapping		

ГРУППЫ ПРИМЕНЕНИЯ

Примеры для групп применения

Ссылка: GOST

11	Автоматные стали
1.0711	A11
1.0715	A15X
1.0718	A20
1.0726	A30
1.0737	A35

12	Конструкционные стали
1.0037	Cr1nc
1.0050	Cr5nc
1.0060	Cr6nc
1.5919	12XH2A
1.7131	18XГ

13	Углеродистые стали
1.0503	45
1.0535	50
1.0601	60
1.1545	Y10A
1.2067	9X2

14	Легированные стали < 850 Н/мм ²
1.2363	X6BФ
1.3551	ШХ10
1.7218	38ХС
1.7220	35ХМ
1.7225	38ХМ

15	Легированные стали > 850 - < 1150 Н/мм ²
1.3553	ШХ15СГ
1.6580	3Х3М3Ф
1.7220	35ХМ
1.7225	38ХМ
1.8507	38Х2МЮА

16	Высокопрочные легированные стали ≤ 44 HRC
1.6582	38Х2Н2МА
1.7225	38ХМ
1.7228	38ХВ
1.8515	40ХН

17	Закалённые легированные стали > 44 - ≤ 54 HRC
> 44 - ≤ 54 HRC	

18	Закалённые легированные стали > 54 - ≤ 63 HRC
> 54 - ≤ 63 HRC	

21	Легко обрабатываемые нержавеющие стали
1.4005	08Х13
1.4104	12Х13
1.4305	14Х17Н2

22	Аустенитные нержавеющие стали
1.4301	08Х18Н10Т
1.4406	03Х16Н15М3
1.4435	03Х17Н14М3
1.4541	12Х18Н10Т
1.4571	10Х17Н13М2Т

23	Ферритные и мартенситные < 850 Н/мм ²
1.4112	14Х17Н2
1.4540	18Х11МНФБ
1.4582	40Х10С2М
1.4762	15Х28
1.4922	20Х12ВНМФЛ

24	Ферритные и мартенситные > 850 - < 1150 Н/мм ²
1.4057	20Х17Н2
1.4125	95Х18
1.4542	18Х15Н3М-Ш
1.4548	55Х20Г9АН4
1.4748	20Х20Н14С2

31	Серый чугун
0.6015	C15
0.6020	C20
0.6025	C25
0.6030	C30

32	Высокопрочный чугун, ковкий чугун
0.7040	B440
0.7043	B450
0.7050	B460
0.7060	B470
0.7080	B480

41	Титан чистый
3.7024	BT1-00
3.7034	BT1-0
3.7055	BT1-1
3.7065	BT1-2

42	Титановые сплавы
3.7124	BT23
3.7164	BT5-1
3.7174	BT6

51	Никелевые сплавы 1 ≤ 850 Н/мм ²
1.3912	36Н
2.4360	НМц2
2.4816	НМц5
1.4876	ХН32Т

52	Никелевые сплавы 2 > 850 - ≤ 1150 Н/мм ²
2.4375	ХН77ТЮР
2.4631	ХН67МВТЮ
2.4668	ХН75МВТЮ

53	Никелевые сплавы 3 > 1150 - ≤ 1600 Н/мм ²
2.4631	ХН35ВТЮ
2.4668	ХН70ВМТЮ

61	Медь чистая
2.0060	М1

62	Латунь короткостружечная, бронза фосфористая, пушечная бронза
2.0401	ЛЦ40С
2.0402	ЛС59-1
2.1030	БрОФ8-0.3
2.1096	БрОФ7-0.2

63	Латунь длинностружечная
2.0240	Л63
2.0265	Л70
2.0321	Л90

64	Латунь бессвинцовая
CuZn21Si3P	(ECoBRASS®)
CuZn35	
CuZn42	

71	Алюминий чистый
3.0205	A98
3.0255	A99

72	Легированный алюминий Si < 1.5 %
3.1255	D16
3.1355	D18
3.2315	D1
3.3206	B95
3.4345	AMr5

73	Легированный алюминий Si > 1.5 % - < 10 %
3.2161	AK7
3.2162	AK9
3.2341	AL6
3.2371	AK7ч

74	Легированный алюминий Si > 10 %, магниевые сплавы
3.2381	AK10су
3.2382	AK12
3.2581	AK12MMrH
3.2583	ML5

81	Термопластики
Делрин	
Тефлон	
Нейлон	

82	Дюропластики
Бакелит	
Новопан	

83	Армированные композитные материалы
Армированные стеклопластики	
Армированные дюро- и термопластики	

91	Желтое золото
2N18	
Au585AgCu205	
3N18	
Au917AgCu44	

92	Красное золото
4N18	
5N18	
Au585CuAg325	
Au750AgCu	
Au917Cu83	

93	Белое золото
Au750PdCu125	
Au750PdCu150	
Au585PdCu150	
Au925Pd75	

94	Серебро
Ag999	
Ag800Cu	
Ag925Cu	

APPLICATION GROUPS

Examples for application groups

Reference:
AISI/ASTM/UNS

11	Free-cutting steels
1.0711	1212
1.0715	1213
1.0718	12L13
1.0726	1140
1.0737	12L14

12	Structural, cementation steels
1.0037	1015
1.0050	A570 Gr.50
1.0060	A572 Gr.55
1.5919	4617
1.7131	5115

13	Carbon steels
1.0503	1045
1.0535	1055
1.0601	1060
1.1545	W110
1.2067	L 3

14	Alloy steels < 850 N/mm ²
1.2363	A2
1.3551	M50
1.7218	4130
1.7220	4135
1.7225	4140

15	Alloy steels hard./temp. > 850 - < 1150 N/mm ²
1.3553	-
1.6580	4340
1.7220	4135
1.7225	4140
1.8507	A355CLD (K23510)

16	High tensile alloy steels ≤ 44 HRC
EN-GJS-1200-2	
1.6582	4340
1.7225	4140
1.7228	4150
1.8515	-

17	Alloy steels tempered > 44 - ≤ 54 HRC
> 44 - ≤ 54 HRC	

18	Alloy steels hardened > 54 - ≤ 63 HRC
> 54 - ≤ 63 HRC	

21	Free machining stainless steels
1.4005	416
1.4104	430F
1.4305	303

22	Austenitic stainless steels
1.4301	304
1.4406	316LN
1.4435	316L
1.4541	321
1.4571	316Ti

23	Ferritic and martensitic < 850 N/mm ²
1.4112	440B
1.4540	XM12
1.4582	-
1.4762	446
1.4821	4922

24	Ferritic and martensitic > 850 - < 1150 N/mm ²
1.4057	431
1.4125	440C
1.4542	630 (17-4PH)
1.4748	-

31	Cast iron
0.6015	A48-25B
0.6020	A48-30B
0.6025	A48-35B
0.6030	A48-45B

32	Spheroidal graphite + malleable cast iron
0.7040	65-45-12
0.7043	60-40-18
0.7050	80-55-06
0.7060	70-60-03
0.7080	120-90-02

41	Pure titanium
3.7024	Gr.1
3.7034	Gr.2
3.7055	Gr.3
3.7065	Gr.4

42	Titanium alloys
3.7124	Alloy 230
	F-1295
3.7164	Gr.5
3.7174	-

51	Nickel alloys 1 ≤ 850 N/mm ²
1.3912	K93600
2.4360	N04400
2.4816	N06600
1.4876	N08800

52	Nickel alloys 2 > 850 - ≤ 1150 N/mm ²
2.4375	N05500 (B865)
2.4631	N07080 (B637)
2.4668	N07718 (B637)

53	Nickel alloys 3 > 1150 - ≤ 1600 N/mm ²
2.4631	N07080 (B637)
2.4668	N07718 (B637)

61	Pure copper (electrolytic copper)
2.0060	C11000

62	Short chip brass, phosphor-bronze, gun metal
2.0401	C38500
2.0402	C37800
2.1030	C52100
2.1096	-

63	Long chip brass
2.0240	C23000
2.0265	C26000
2.0321	C27200

64	Lead free brass
CuZn21Si3P (ECOBRESS®)	
CuZn35	
CuZn42	

71	Al unalloyed
3.0205	1200
3.0255	1050A

72	Al alloyed Si < 1.5 %
3.1255	2014
3.1355	2024
3.2315	6082
3.3206	6060
3.4345	7022

73	Al alloyed Si > 1.5 % - < 10 %
3.2161	327
3.2162	-
3.2341	-
3.2371	356

74	Al alloyed Si > 10 %, Mg-alloys
3.2381	A360
3.2382	-
3.2581	A413
3.2583	413.1

81	Thermoplastics
Delrin (POM)	
Teflon	
Nylon	

82	Duroplastics
Bakelit	
Novopan	

83	Glass fibre reinforced plastics
Glass fibre reinforced, Thermo and Duroplastics	

91	Yellow gold
2N18	
Au585AgCu205	
3N18	
Au917AgCu44	

92	Red gold
4N18	
5N18	
Au585CuAg325	
Au750AgCu	
Au917Cu83	

93	White gold
Au750PdCu125	
Au750PdCu150	
Au585PdCu150	
Au925Pd75	

94	Silver
Ag999	
Ag800Cu	
Ag925Cu	

ТАБЛИЦА ПРИМЕНЕНИЯ — APPLICATION CHART

Нарезание резьбы Thread cutting

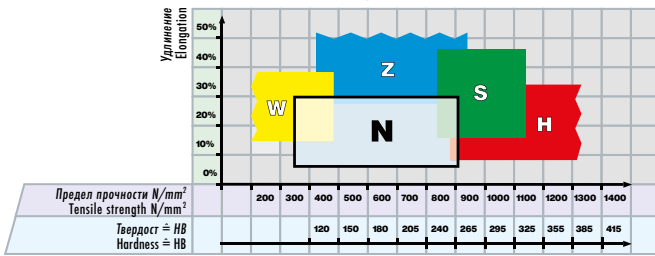

Нарезание резьбы Thread cutting

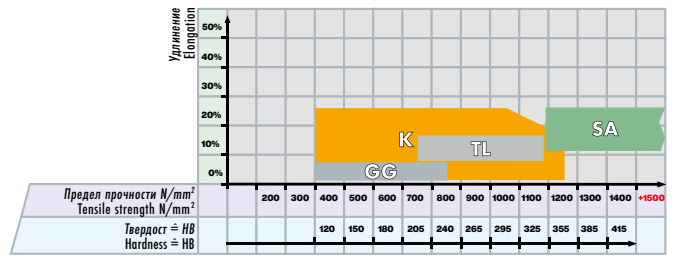

Нарезание резьбы и скоростное Thread cutting classic and rigid

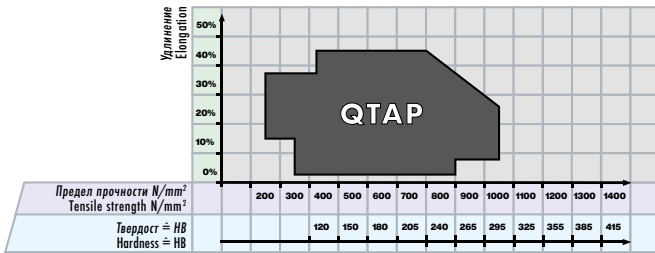

Скоростное нарезание резьбы Rigid Tapping

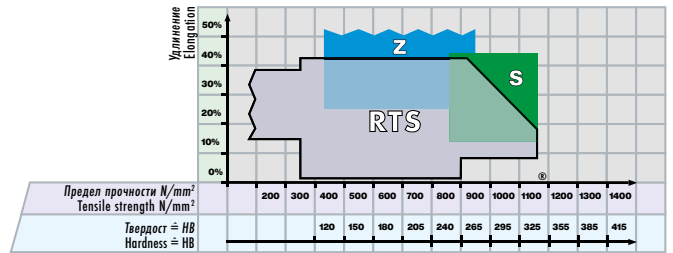

DC Классификация материалов

DC Material classification

Группы материалов Material groups	Обозначение материалов	Material designation	Твердость Hardness (HB)	Предел прочности Tensile strength Rm (N/mm ²)	Удлинение Elongation A (%)
10 Стали Steels	11 Легко обрабатываемые стали	Free-cutting steels	< 200	< 700	< 10
	12 Структурные, цементуемые стали	Structural, cementation steels	< 200	< 700	< 30
	13 Углеродистые стали	Carbon steels	< 300	< 1000	< 20
	14 Легированные стали < 850 N/mm ²	Alloy steels < 850 N/mm ²	< 250	< 850	< 30
	15 Легированные стали закал./отп. > 850 - < 1150 N/mm ²	Alloy steels hard. / temp. > 850 - < 1150 N/mm ²	> 250	> 850	< 30
	16 Высокопрочные легированные стали ≤ 44 HRC	High tensile alloy steels ≤ 44 HRC	> 250	> 850	< 12
	17 Закалённые легированные стали > 44 - ≤ 54 HRC	Alloy steels tempered > 44 - ≤ 54 HRC	> 410	> 1400	< 2
	18 Закалённые легированные стали > 54 - ≤ 63 HRC	Alloy steels hardened > 54 - ≤ 63 HRC	> 560	> 1980	< 2
20 Нержавеющие стали Stainless steels	21 Легко обрабатываемые нержавеющие стали	Free machining stainless steels	< 250	< 850	< 25
	22 Аустенитные нержавеющие стали	Austenitic stainless steels	< 250	< 850	> 20
	23 Ферритные и мартенситные < 850 N/mm ²	Ferritic and martensitic < 850 N/mm ²	< 250	< 850	> 20
	24 Ферритные и мартенситные > 850 - < 1150 N/mm ²	Ferritic and martensitic > 850 - < 1150 N/mm ²	> 250	> 850	> 15
30 Чугун Cast iron	31 Чугун	Cast iron	< 250	< 850	< 10
	32 Высокопрочные и ковкий чугун	Spheroidal graphite + malleable cast iron	< 250	< 850	> 10
40 Титан Titanium	41 Чистый титан	Pure titanium	< 250	< 850	> 20
	42 Титановые сплавы	Titanium alloys	> 250	> 850	< 20
50 Никель Nickel	51 Никелевые сплавы 1 ≤ 850 N/mm ²	Nickel alloys 1 ≤ 850 N/mm ²	< 250	< 850	> 25
	52 Никелевые сплавы 2 > 850 - ≤ 1150 N/mm ²	Nickel alloys 2 > 850 - ≤ 1150 N/mm ²	> 250	> 850	< 25
	53 Никелевые сплавы 3 > 1150 - ≤ 1600 N/mm ²	Nickel alloys 3 > 1150 - ≤ 1600 N/mm ²	> 340	> 1150	< 20
60 Медь Copper	61 Медь чистая (электротехническая)	Pure copper (electrolytic copper)	< 120	< 400	> 12
	62 Короткостружечная латунь, фосфористая бронза	Short chip brass, phosphor bronze, gun metal	< 200	< 700	< 12
	63 Длинностружечная латунь	Long chip brass	< 200	< 700	> 12
	64 Безсвинцовая латунь	Lead free brass	< 220	< 700	> 15
70 Алюминий Магний Aluminium Magnesium	71 Алюминий чистый	Al unalloyed	< 100	< 350	> 15
	72 Алюминиевые сплавы Si < 1.5 %	Al alloyed Si < 1.5 %	< 150	< 500	> 15
	73 Алюминиевые сплавы Si > 1.5 % - < 10 %	Al alloyed Si > 1.5 % - < 10 %	< 120	< 400	< 15
	74 Алюминиевые сплавы Si > 10 %, магниевые сплавы	Al alloyed Si > 10 %, Mg-alloys	< 120	< 400	< 10
80 Пластики Plastic compounds	81 Термопластики	Thermoplastics	-	-	-
	82 Дюропластики	Duroplastics	-	-	-
	83 Пластики армированные стекловолокном	Glass fibre reinforced plastics	-	-	-
90 Драгоценные металлы Precious metals	91 Желтое золото	Yellow gold	-	-	-
	92 Красное золото	Red gold	-	-	-
	93 Белое золото	White gold	-	-	-
	94 Серебро	Silver	-	-	-

НАРЕЗАНИЕ РЕЗЬБЫ — CLASSIC THREAD CUTTING



Со страницы:
From page:

MJ / M
MF
UNC / UNC / UNC(J)
UNF / UNF / UNF(J)
UNEF / UN / UNS
G / Rp / Rc / W / SV
NPT / NPTF
PG / TR
EG M / EG UNC / EG UNF

N
Нормальные материалы
Normal materials

	60	62	60	64	64	72	72	74	60	74	74
	125	124	125	125		124		131	131	131	
	154	154	154	154				156	156	156	
	176	176	176	176				178	178	178	
	198	198						199	199		
	204	205	205	205				206	206	206	
	220										
	222	222									
		226	226					227	227		

	N.10	N.20	N.20V	N.20TN	N.20TC	N.50	N.50V	N.60	N.60V	N.60TN	N.60TC

W
Мягкие материалы
Soft materials

	86	86	87	87
			207	207

	W.20	W.20DL	W.60	W.60DL

V_c (m/min)
< Ø 20 mm Общие указания Guide Line
Стандартный Standard +V / +NV
С покрытием Coated TN / TC / DL / VS

11	10 - 15	25 - 35										11
12	10 - 15	25 - 35										12
13	8 - 12	16 - 24										13
14	8 - 12	16 - 24										14
15	3 - 5	6 - 12										15
16	3 - 5	3 - 5										16
17	2 - 4											17
18												18
21	10 - 15	20 - 30										21
22	3 - 6	6 - 12										22
23	3 - 6	6 - 12										23
24		4 - 8										24
31	10 - 15	20 - 30										31
32	10 - 15	20 - 30										32
41	4 - 8	4 - 8										41
42	3 - 5	3 - 5										42
51		6 - 12										51
52	4 - 8	4 - 8										52
53	2 - 4											53
61	8 - 12	12 - 16										61
62	20 - 30	30 - 40										62
63	16 - 24											63
64	16 - 24											64
71	10 - 15	20 - 40										71
72	20 - 30	20 - 40										72
73	10 - 15	20 - 30										73
74	10 - 15	20 - 30										74
81	20 - 30	30 - 50										81
82	8 - 16	16 - 24										82
83		8 - 16										83
91	20 - 30											91
92		12 - 16										92
93		4 - 8										93
94		16 - 24										94

E Допустимо с эмульсией
Suitable with emulsion

A Оптимально с воздухом
Optimal with air

A Допустимо с воздухом
Suitable with air

НАРЕЗАНИЕ РЕЗЬБЫ И СКОРОСТНОЕ НАРЕЗАНИЕ РЕЗЬБЫ С ЧПУ CLASSIC THREAD CUTTING AND RIGID TAPPING



Со страницы:
From page:

MJ / M
MF
UNJC / UNC / UNC(J)
UNJF / UNF / UNF(J)
UNEF / UN / UNS
G / Rp / Rc / W / SV
NPT / NPTF
PG / TR
EG M / EG UNC / EG UNF

K Серия "K" для глубоких резьб Swarf breaker	
104	105
142	



K.13TC K.13VS



QTAP Универсальный метчик Allrounder			
61	106	61	107
143	143	144	144
167	167	168	168
192	192	193	193
210	210	211	211



Q.20VS Q.23VS Q.60VS Q.63VS



Vc (m/min) Guide Line				
	Ø 5 - 10.9 mm	Ø 11 - 18.9 mm	Ø 19 - 31.9 mm	Ø 32 - 42 mm

	Ø 5 - 10.9 mm	Ø 11 - 18.9 mm	Ø 19 - 31.9 mm	Ø 32 - 42 mm
11	30 - 40	20 - 30	20 - 30	20 - 30
12	30 - 40	20 - 30	20 - 30	20 - 30
13	30 - 40	20 - 30	20 - 30	20 - 30
14	20 - 30	15 - 25	15 - 25	15 - 25
15	15 - 20	10 - 15	8 - 12	5 - 8
16	8 - 12	5 - 8	5 - 8	5 - 8
17				
18				
21				
22				
23				
24				
31	30 - 40	30 - 40	30 - 40	30 - 40
32	30 - 40	20 - 30	20 - 30	20 - 30
41				
42				
51				
52				
53				
61				
62	30 - 40	30 - 40	30 - 40	30 - 40
63	30 - 40	30 - 40	30 - 40	30 - 40
64	30 - 40	20 - 30	20 - 30	20 - 30
71				
72				
73				
74	30 - 40	30 - 40	30 - 40	30 - 40
81				
82				
83	30 - 40	30 - 40	30 - 40	30 - 40
91				
92				
93				
94				

Vc (m/min) Guide Line	
	Ø 2.8 - 20 mm

	Ø 2.8 - 20 mm				
20 - 40					11
20 - 40					12
16 - 24					13
16 - 24					14
6 - 12					15
					16
					17
					18
20 - 40					21
6 - 12					22
6 - 12					23
4 - 8					24
20 - 40					31
20 - 40					32
					41
					42
6 - 12					51
4 - 8					52
					53
12 - 16					61
25 - 35					62
20 - 40					63
20 - 40					64
20 - 40					71
20 - 40					72
20 - 40					73
20 - 40					74
20 - 40					81
16 - 24					82
8 - 16					83
20 - 40					91
12 - 16					92
					93
12 - 16					94

E Допустимо с эмульсией
Suitable with emulsion

A Оптимально с воздухом
Optimal with air

A Допустимо с воздухом
Suitable with air

ОБРАЗОВАНИЕ РЕЗЬБЫ РАСКАТНИКАМИ — RIGID TAPPING

Со страницы:
From page:

MJ / M
MF
UNJC / UNC / UNC(J)
UNJF / UNF / UNF(J)
UNEF / UN / UNS
G / Rp / Rc / W / SV
NPT / NPTF
PG / TR
EG M / EG UNC / EG UNF

RTS

Скоростное нарезание резьбы
Synchro

Z

Вязкие материалы
Tough materials

S

Специальные сплавы
Special alloys

Vc
(m/min)
Guide Line





Ø 2 - 2.8 mm	Ø 2.8 - 20 mm
--------------	---------------



108	108	109	109
145		145	
169		169	
194		194	
		212	



90	90
134	
160	
182	
209	
231	

46	On request
48	
50	









RTS.20VS	RTS.23VS	RTS.60VS RTS.62VS	RTS.65VS
			







Z.70VS	Z.73VS
	

S.70VX	S.73VX
	





	Vc (m/min) Guide Line		RTS				Z		S		
	Ø 2 - 2.8 mm	Ø 2.8 - 20 mm	RTS.20VS	RTS.23VS	RTS.60VS RTS.62VS	RTS.65VS	Z.70VS	Z.73VS	S.70VX	S.73VX	
11	12 - 20	20 - 40	OE	OE	OE	OE	OE	OE			11
12	12 - 20	20 - 40	OE	OE	OE	OE	OE	OE			12
13	12 - 20	16 - 24	OE	OE	OE	OE	OE	OE			13
14	12 - 20	16 - 24	OE	OE	OE	OE	OE	OE			14
15	5 - 10	6 - 12	OE	OE	OE	OE	OE	OE	OE	OE	15
16											16
17											17
18											18
21	12 - 20	20 - 40	OE	OE	OE	OE	OE	OE			21
22	4 - 10	6 - 12	OE	OE	OE	OE	OE	OE	OE	OE	22
23	4 - 10	6 - 12	OE	OE	OE	OE	OE	OE	OE	OE	23
24	4 - 8	4 - 8	OE	OE	OE	OE	OE	OE	OE	OE	24
31	12 - 20	20 - 40	OE A	OE	OE A	OE	OE	OE			31
32	12 - 20	20 - 40	OE	OE	OE	OE	OE	OE			32
41											41
42											42
51	4 - 10	6 - 12	OE	OE	OE	OE	OE	OE	OE	OE	51
52		4 - 8									52
53											53
61	10 - 16	10 - 20	OE	OE	OE	OE	OE	OE			61
62											62
63	12 - 20	20 - 40	OE	OE	OE	OE					63
64	12 - 20	20 - 40	OE	OE	OE	OE					64
71	12 - 20	30 - 50	OE	OE	OE	OE					71
72	12 - 20	30 - 50	OE	OE	OE	OE					72
73	12 - 20	20 - 40	OE	OE	OE	OE					73
74	12 - 20	20 - 40	OE A	OE	OE A	OE					74
81	12 - 20	30 - 50	OE A	OE	OE A	OE					81
82	12 - 20	16 - 24	OE	OE	OE	OE					82
83	4 - 10	8 - 16	OE A	OE	OE A	OE					83
91	12 - 20	20 - 40	OE	OE	OE	OE					91
92	6 - 12	12 - 16	OE	OE	OE	OE					92
93											93
94	6 - 12	12 - 16	OE	OE	OE	OE					94

РУБРИКАТОР — REGISTER

	<p><i>Нарезание резьбы</i> Classic thread cutting</p>		<p><i>Классическое и синхронное нарезание резьбы</i> Classic thread cutting and Rigid Tapping</p>
<p>MJ S 46 SA 46/47 TL 47</p> <p>UNJC S 48 SA 48/49 TL 49</p> <p>UNJF S 50 SA 50/51 TL 51</p> <p>M N 60/62-85/114-115/118 NP 116-117 W 86-87 Z 88-91 ZX 93 H 94-97 S 98-99 SA 99-101 TL 100-101 GG 102-103</p> <p>MF N 124-133/146-148 Z 134-135 H 136-137 S 138 SA 139-141 TL 140-141</p> <p>UNC, UNC(J) N 154-157/170-171 Z 158-160 H 161-162 S 163-164 SA 165-166 TL 165</p> <p>UNF, UNF(J), UNEF, UN, UNS N 176-179/196-199 Z 180-182 H 184-185 S 186 SA 188-190 TL 188-189</p> <p>G (BSP), Rp, Rc, W, SV Schaublin N 204-206/213-217 W 207 H 207 GG 207 Z 208-209</p> <p>NPT, NPTF, PG, TR N 220-223</p> <p>EG M, EG UNC, EG UNF N 226-227/230/233 Z 231/234 S 234 SA 228-229/232/234-235 TL 228/232/235</p>		<p>M K 104-105 Q 61/106-107</p> <p>MF K 142 Q 143-144</p> <p>UNC, UNF Q 167-168 / 192-193</p> <p>G (BSP) Q 210-211</p>	
			<p><i>Синхронное нарезание резьбы</i> Rigid Tapping</p>
		<p>M RTS 108-112 Z.70/Z.73 90-91</p> <p>MF RTS 145 Z.70 134-135</p> <p>UNC, UNC(J) RTS 169 Z.70 160</p> <p>UNF, UNF(J) RTS 194 Z.70 182</p> <p>G (BSP) RTS 212 Z.70 209</p> <p>EG UNC, EG UNF Z 231/234</p>	
			<p><i>Раскатники</i> Thread forming</p>
	<p><i>Корончатые метчики</i> Crown taps</p>	<p>M FS 254-255 FPS 256-258 FAS 259-261</p> <p>MF FPS 262 FAS 262</p> <p>UNC FS 263 FPS 263 FAS 263</p> <p>UNF FS 264 FPS 264 FAS 264</p>	
<p>M, MF, UN, G (BSP) N 237-239</p>			
	<p><i>Комбинированные сверла/метчики</i> Combination drill/taps</p>	<p>G (BSP) FPS 265 FAS 265</p>	
<p>M, MF, UNC, G (BSP), PG N 242-243</p>			

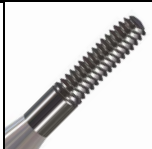
	<p>Плашки Dies</p>		<p>Патроны для синхронного нарезания SRT Tapping chucks SRT</p>												
<p>M N 272/286/288/289 Z 273/286 Z.LL 273</p> <p>MF N 274-276/287/288 Z 274-275</p> <p>UNC N 277</p> <p>UNF, UNEF, UN, UNS N 278-279</p> <p>G (BSP), R (DIN EN 10226, ISO 7-1) N 280/282/289 Z 281 MS 281</p> <p>NPT, NPTF, PG, TR N 283-284</p> <p>W N 285/289</p>	<table border="0"> <tr> <td>HSK</td> <td>306</td> <td>BT40</td> <td>306</td> </tr> <tr> <td>SK40/SK50</td> <td>307</td> <td>DIN 1835 B</td> <td>308-309</td> </tr> </table>	HSK	306	BT40	306	SK40/SK50	307	DIN 1835 B	308-309	 <p>Вставки Inserts</p>	<table border="0"> <tr> <td>S</td> <td>310</td> <td>SC</td> <td>311</td> </tr> </table>	S	310	SC	311
HSK	306	BT40	306												
SK40/SK50	307	DIN 1835 B	308-309												
S	310	SC	311												
	<p>Резьбовые калибры Thread gauges</p>		<p>Принадлежности Accessories</p>												
<p>M D 294-295</p> <p>MF D 296-299</p> <p>UNC D 300</p> <p>UNF, UNEF D 301</p> <p>G (BSP), PG D 302</p> <p>NPT, NPTF D 303</p> <p>EG M, EG UNC, EG UNF D 304</p>	<p>Твердосплавные центровочные сверла Solide carbide spotting drills</p> <p>C315VS 318</p> <p>Твердосплавные сверла Solide carbide twist drills</p> <table border="0"> <tr> <td>FZ315VS</td> <td>319</td> <td>F313VS</td> <td>320</td> </tr> <tr> <td>F285VS</td> <td>320</td> <td>F286VS</td> <td>320</td> </tr> </table> <p>Плашкодержатели Die stocks</p> <p>D5810 322</p> <p>Воротки для метчиков Tap wrenches</p> <p>D5820 322</p> <p>Удлинитель для метчиков Tap extension sleeves</p> <table border="0"> <tr> <td>D5830</td> <td>323</td> <td>D5840</td> <td>323</td> </tr> </table>	FZ315VS	319	F313VS	320	F285VS	320	F286VS	320	D5830	323	D5840	323		
FZ315VS	319	F313VS	320												
F285VS	320	F286VS	320												
D5830	323	D5840	323												
															
<p>Техническая информация Условия поставки и оплаты</p>	<p>Техническая информация Условия поставки и оплаты</p> <p>Дальнейшая информация доступна на www.dcswiss.com</p>														

РУБРИКАТОР — REGISTER

	Машинные метчики nano Machine taps nano		Машинные раскатники nano Machine thread formers nano	
M TAN 338 TAZ 339 CMS 340 MF TAN 341 TAZ 342 CMS 343 UNC TAN 344 TAZ 345 CMS 346 UNF TAN 347 TAZ 348 CMS 349 S TAN 350 TAZ 351 CMS 352 SF TAN 353 TAZ 354 CMS 355 SL TAN 356 TAZ 357 CMS 358		M FA80 363 FA83 363 CFA80 370 CFA83 370 MF FA80 364 FA83 364 UNC FA80 365 FA83 365 CFA80 371 CFA83 371 UNF FA80 366 FA83 366 CFA80 372 CFA83 372 S FA80 367 FA83 367 CFA80 373 CFA83 373 SF FA80 368 FA83 368 SL FA80 369 FA83 369		
	Резьбовые калибры nano Thread gauges nano			
M DN01 382 DN02 382 DZ04 383 DZ14 383 DN04 384 DN14 384 MF DN01 385 DN02 385 DZ04 386 DZ14 386 DN04 387 DN14 387 UNC, UNF DN01 388 DN02 388 DZ04 389 DZ14 389 DN04 390 DN14 390 S NIHS, S NIHS NT DN01 391-392 DN02 391-392 DZ04 393 DZ14 393 DN04 394 DN14 394 SF NIHS, SF NIHS NT DN01 395 DN02 395 DZ04 396 DZ14 396 DN04 397 DN14 397 *SL DN01 398 DN02 398	*SL: только без сертификата SCS *SL: only available without certificate SCS		Контр-калибры nano Контр-калибры износа nano Калибрующие резьбовые пробки Plug check gauges nano Master plug gauges WEAR nano Calibration thread plug gauges nano	
 <p>Все nano резьбовые калибры-пробки сертифицированы SCS, а платный сертификат доступен по заказу. All nano thread plug gauges are SCS-certified and the paid certificate is available on request.</p>  <p>Все nano резьбовые калибры-кольца имеют сертификат соответствия, установленный с помощью SCS сертифицированных контр-калибров. Платный сертификат доступен по заказу. All nano ring gauges have a certificate of measurement, established with SCS certified plug check gauges. The paid certificate is available on request.</p>			M RN05-1 399 RN15-1 399 RN05-2 400 RN15-2 400 RN05-3 401 RN15-3 401 MF RN05-1 402 RN15-1 402 RN05-2 403 RN15-2 403 RN05-3 404 RN15-3 404 UNC, UNF RN05-1 405 RN15-1 405 RN05-2 406 RN15-2 406 S NIHS, S NIHS NT RN05-1 407 RN15-1 407 RN05-2 408 RN15-2 408 SF NIHS, SF NIHS NT RN05-1 409 RN15-1 409 RN05-2 410 RN15-2 410 S NIHS EN00 411	
			SCS сертификат прилагается. SCS certificate included.	

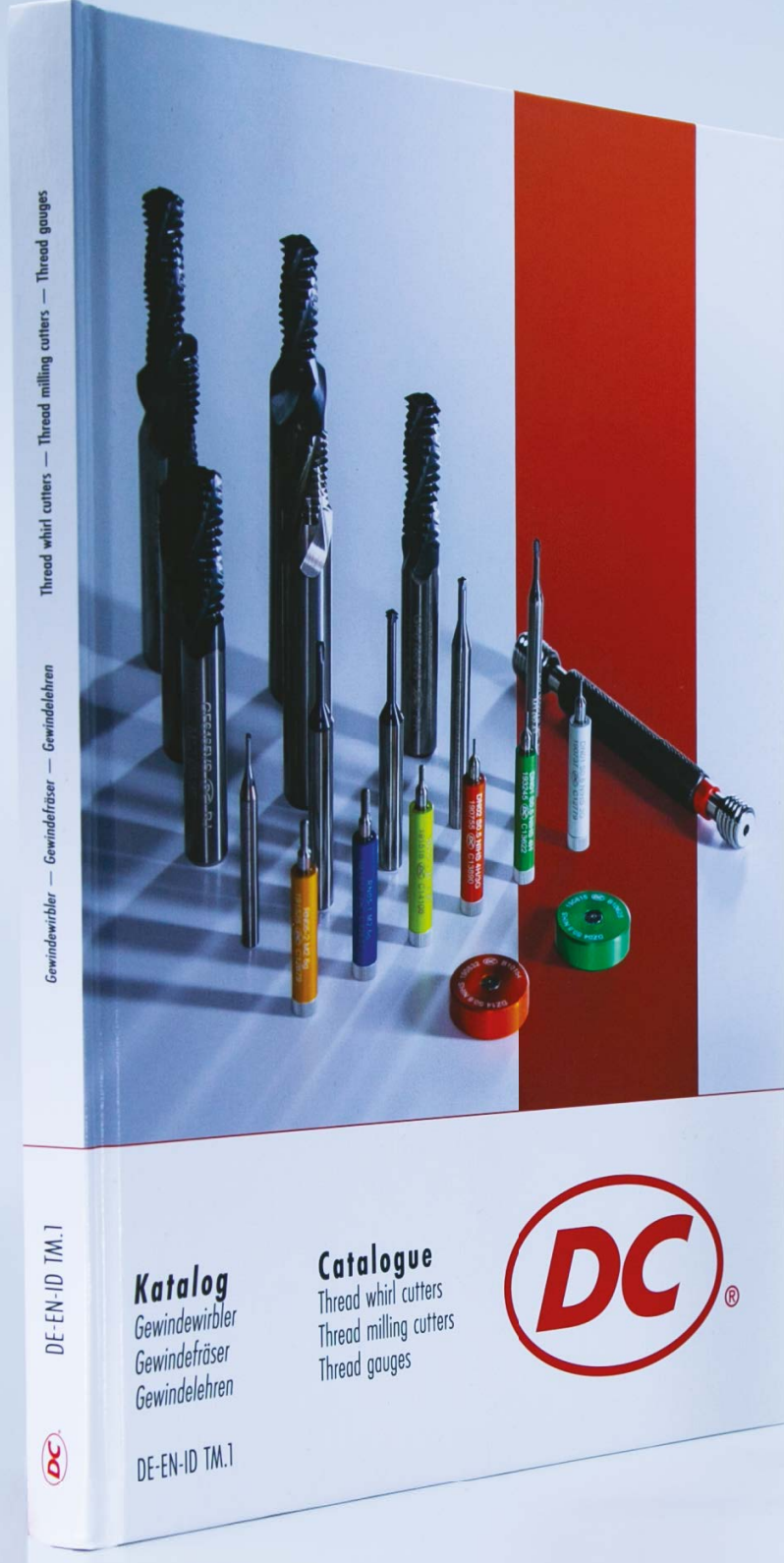













**ДЛЯ ТВЕРДОСПЛАВНЫХ РЕЗЬБОВЫХ ФРЕЗ
И РЕЗЬБОВЫХ МИКРО ФРЕЗ, ПОЖАЛУЙСТА,
ОБРАТИТЕСЬ К НАШЕМУ
КАТАЛОГУ ТМ!**

**FOR SOLID CARBIDE THREAD MILLING CUTTERS AND
THREAD WHIRL CUTTERS PLEASE ASK FOR OUR
CATALOGUE TM!**

MJ, UNJC, UNJF

Указатель — Машинные метчики MJ ISO 5855, UNJC / UNJF ISO 3161/ASME B1.15
 Directory — Machine taps MJ ISO 5855, UNJC / UNJF ISO 3161/ASME B1.15

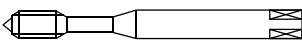
				S		SA	
Характеристики Characteristics				 VS	 R45 VX		 R15
				 NEW	 NEW	 NEW	 NEW
Типы отверстий Hole type							
				S320VS-4	S370VX-3	SA320-4	SA350-3
MJ 4H6H /4H5H	ISO 5855	Длинный по DIN DIN long	DIN 371	46	46	47	47
UNJC 3B	ISO 3161/ASME B1.15	Длинный по DIN DIN long	DIN 371	48	48	49	49
UNJF 3B	ISO 3161/ASME B1.15	Длинный по DIN DIN long	DIN 371	50	50	51	51



Composites
GWi3067VX



Super alloys
SA390-3



Titanium alloys
TL351VS-3

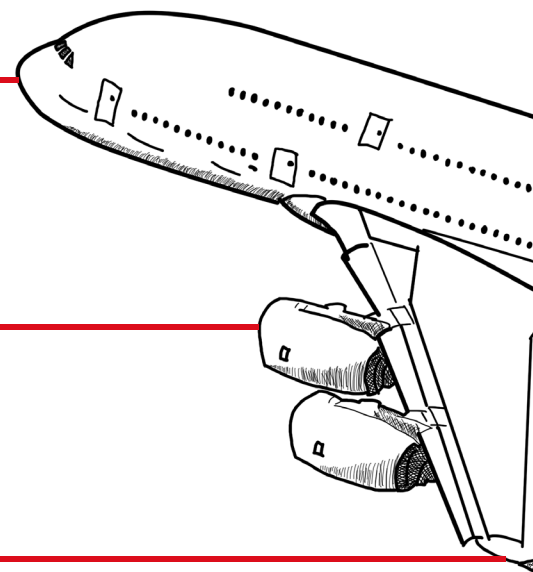

MJ, UNJC, UNJF

Указатель — Машинные метчики MJ ISO 5855, UNJC / UNJF ISO 3161/ASME B1.15
 Directory — Machine taps MJ ISO 5855, UNJC / UNJF ISO 3161/ASME B1.15

SA	TL
 R10	 R15  VS
 NEW	 NEW
	
SA390-3	TL351VS-3
46	47
48	49
50	51

Aluminium alloys
W360DL-3

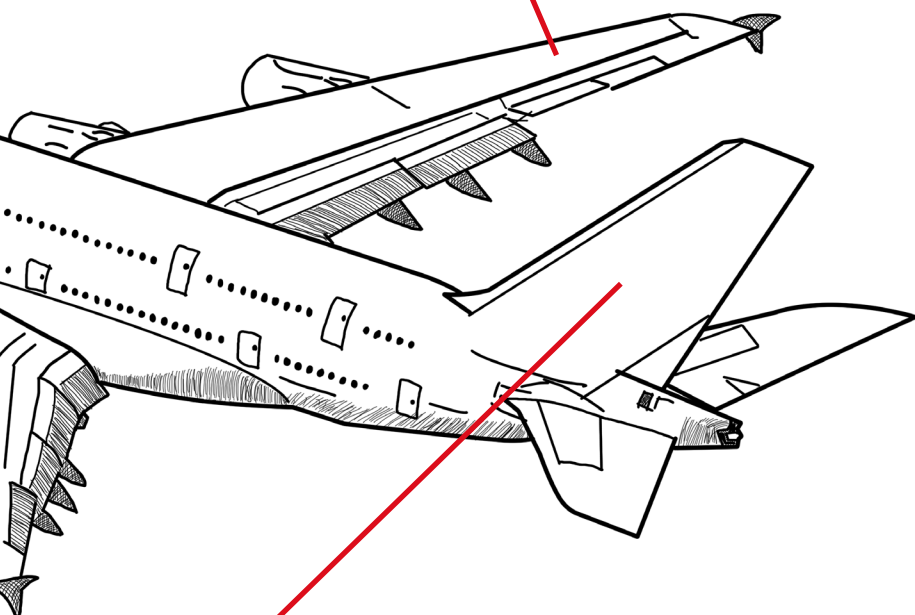

Glass fibre reinforced plastics
H350TC-3



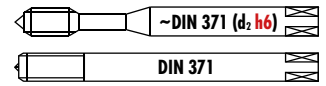
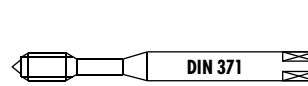

										S320VS-4	S370VX-3	SA390-3
S320VS-4												
S370VX-3												
<h1>aero</h1>												
SA390-3												
$\emptyset d_1$ MJ	P mm	l_1 mm	l_2 mm	l_3 mm	d_2 mm	a mm			ID			
3	0.5	56	12	18	3.5	2.7	3	2.55	● 198966			
4	0.7	63	14	21	4.5	3.4	3	3.4	● 198967			
5	0.8	70	15	25	6	4.9	3	4.3	● 198968			
6	1	80	17	30	6	4.9	3	5.1	● 198969			
8	1	90	20	35	8	6.2	3	7.1	● 198970			
8	1.25	90	20	35	8	6.2	3	6.9	● 198971			
10	1.25	100	22	39	10	8	3	8.9	● 198972			
10	1.5	100	22	39	10	8	3	8.6	● 198973			
$\emptyset d_1$ MJ	P mm	l_1 mm	l_2 mm	l_3 mm	d_2 h6 mm	a mm			ID			
3	0.5	56	5.5	18	3.5(h9)	2.7	3	2.55	● 198974			
4	0.7	63	7.5	21	4.5(h9)	3.4	3	3.4	● 198975			
5	0.8	70	9	25	6	4.9	3	4.3	● 198976			
6	1	80	11	30	6	4.9	3	5.1	● 198977			
8	1	90	12.5	35	8	6.2	3	7.1	● 198978			
8	1.25	90	12.5	35	8	6.2	3	6.9	● 198979			
10	1.25	100	14	39	10	8	3	8.9	● 198980			
10	1.5	100	14	39	10	8	3	8.6	● 198981			
$\emptyset d_1$ MJ	P mm	l_1 mm	l_2 mm	d_2 mm	a mm			ID				
3	0.5	56	12	3.5	2.7	3	2.55	● 199006				
4	0.7	63	14	4.5	3.4	3	3.4	● 199007				
5	0.8	70	15	6	4.9	3	4.3	● 199008				
6	1	80	20	6	4.9	3	5.1	● 199009				
8	1	90	25	8	6.2	3	7.1	● 199010				
8	1.25	90	25	8	6.2	3	6.9	● 199011				
10	1.25	100	30	10	8	3	8.9	● 199012				
10	1.5	100	30	10	8	3	8.6	● 199013				

≤MJ5x0.8 = **4H6H**

aero

SA320-4



15 16 52 64

SA350-3



15 16 52 64

TL351VS-3



41 42

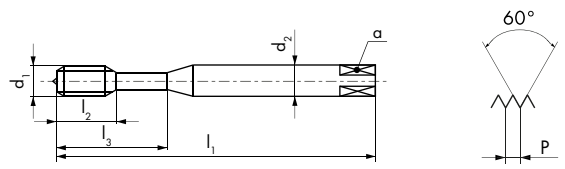



SA320-4

SA350-3

TL351VS-3



$\emptyset d_1$ MJ	P mm	l_1 mm	l_2 mm	l_3 mm	d_2 mm	a mm			ID	ID	ID
3	0.5	56	12		3.5	2.7	3	2.55	● 198990	● 198998	● 198982
4	0.7	63	14		4.5	3.4	3	3.4	● 198991	● 198999	● 198983
5	0.8	70	15		6	4.9	3	4.3	● 198992	● 199000	● 198984
6	1	80	15	23	6	4.9	3	5.1	● 198993	● 199001	● 198985
8	1	90	18	29	8	6.2	3	7.1	● 198994	● 199002	● 198986
8	1.25	90	18	29	8	6.2	3	6.9	● 198995	● 199003	● 198987
10	1.25	100	20	33	10	8	3	8.9	● 198996	● 199004	● 198988
10	1.5	100	20	33	10	8	3	8.6	● 198997	● 199005	● 198989

$\leq MJ5 \times 0.8 =$ **4H6H**

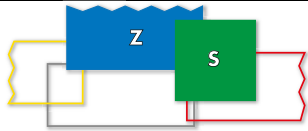
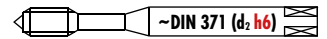
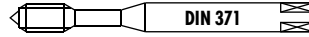

S320VS-4

S370VX-3



aero

SA390-3

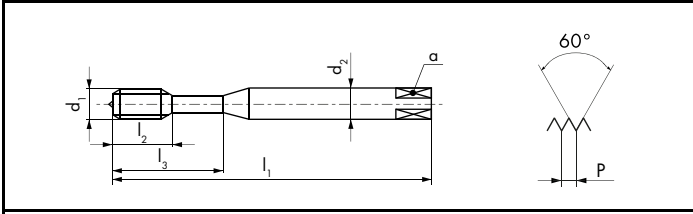
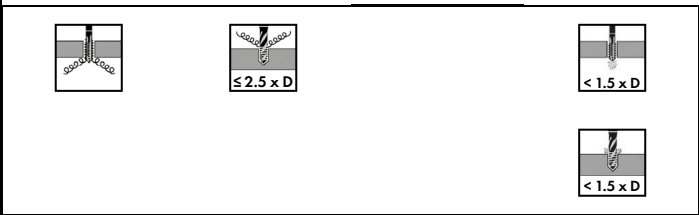

B 4 x P **C** 2.5 x P **C** 2.5 x P

3B **3B** **3B**

Ø" d ₁ UNJC	P TPI	d ₁ mm	l ₁ mm	l ₂ mm	l ₃ mm	d ₂ mm	a mm		
6	32	3.5	56	13	20	4	3	3	2.8
8	32	4.16	63	14	21	4.5	3.4	3	3.45
10	24	4.82	70	15	25	6	4.9	3	3.9
1/4	20	6.35	80	17	30	7	5.5	3	5.2

ID
● 199014
● 199015
● 199016
● 199017

Ø" d ₁ UNJC	P TPI	d ₁ mm	l ₁ mm	l ₂ mm	l ₃ mm	d ₂ h6 mm	a mm		
6	32	3.5	56	6.5	20	4 (h9)	3	3	2.8
8	32	4.16	63	7.5	21	4.5(h9)	3.4	3	3.45
10	24	4.82	70	9	25	6	4.9	3	3.9
1/4	20	6.35	80	11	30	6	4.9	3	5.2

ID
● 199018
● 199019
● 199020
● 199021

Ø" d ₁ UNJC	P TPI	d ₁ mm	l ₁ mm	l ₂ mm	d ₂ mm	a mm		
6	32	3.5	56	13	4	3	3	2.8
8	32	4.16	63	14	4.5	3.4	3	3.45
10	24	4.82	70	15	6	4.9	3	3.9
1/4	20	6.35	80	20	7	5.5	3	5.2

ID
● 199034
● 199035
● 199036
● 199037

aero

SA320-4



15 16 52 64

SA350-3



15 16 52 64

TL351VS-3





41 42

SA320-4

SA350-3

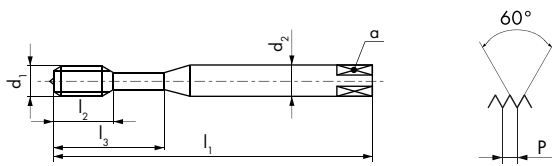
TL351VS-3



Ø" d ₁ UNJC	P TPI	d ₁ mm	l ₁ mm	l ₂ mm	l ₃ mm	d ₂ mm	a mm		
6	32	3.5	56	13		4	3	3	2.8
8	32	4.16	63	14		4.5	3.4	3	3.45
10	24	4.82	70	15		6	4.9	3	3.9
1/4	20	6.35	80	15	23	7	5.5	3	5.2

ID	ID	ID
● 199026	● 199030	● 199022
● 199027	● 199031	● 199023
● 199028	● 199032	● 199024
● 199029	● 199033	● 199025

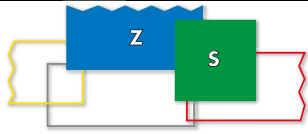
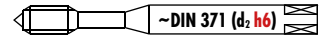
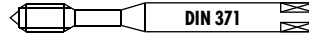

S320VS-4



S370VX-3



aero

SA390-3



S320VS-4

S370VX-3

SA390-3

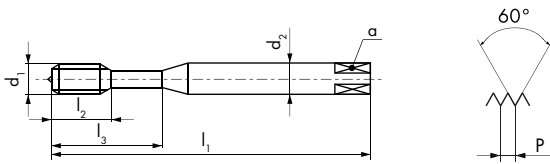

Ø" d ₁ UNJF	P TPI	d ₁ mm	l ₁ mm	l ₂ mm	l ₃ mm	d ₂ mm	a mm		
10	32	4.82	70	15	25	6	4.9	3	4.1
1/4	28	6.35	80	17	30	7	5.5	3	5.55
5/16	24	7.93	90	20	35	8	6.2	3	7
3/8	24	9.52	100	22	39	10	8	3	8.6

ID

- 199038
- 199039
- 199040
- 199041

Ø" d ₁ UNJF	P TPI	d ₁ mm	l ₁ mm	l ₂ mm	l ₃ mm	d ₂ h ₆ mm	a mm		
10	32	4.82	70	9	25	6	4.9	3	4.1
1/4	28	6.35	80	11	30	6	4.9	3	5.55
5/16	24	7.93	90	12.5	35	8	6.2	3	7
3/8	24	9.52	100	14	39	10	8	3	8.6

ID

- 197707
- 197708
- 197709
- 197710

Ø" d ₁ UNJF	P TPI	d ₁ mm	l ₁ mm	l ₂ mm	d ₂ mm	a mm		
10	32	4.82	70	15	6	4.9	3	4.1
1/4	28	6.35	80	20	7	5.5	3	5.55
5/16	24	7.93	90	25	8	6.2	3	7
3/8	24	9.52	100	30	10	8	3	8.6







ID

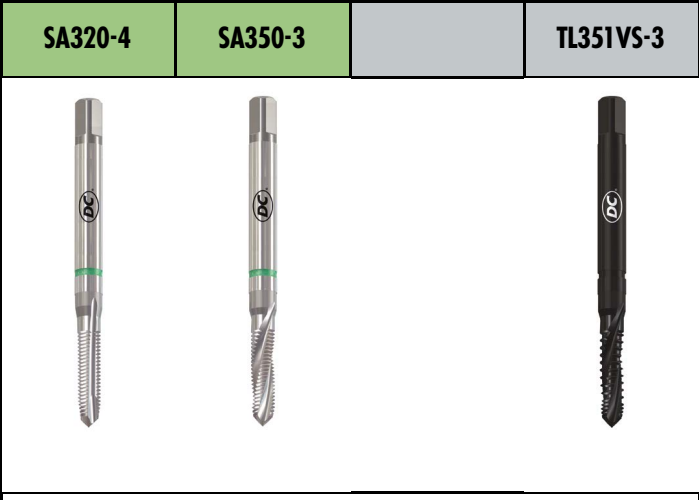



- 199049
- 199050
- 199051
- 199052

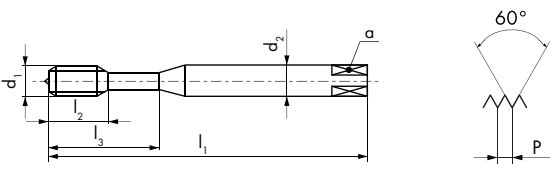

aero

SA320-4  15 16 52 64	SA350-3  15 16 52 64		TL351VS-3
---	---	--	------------------



TL351VS-3  R15  VS 41 42		 < 1.5 x D	 < 2 x D  < 2 x D
--	---	---	--

	 B 4 x P	 C 2.5 x P	 C 2.5 x P
	3B	3B	3B























\emptyset " d_1 UNJF	P TPI	d_1 mm	l_1 mm	l_2 mm	l_3 mm	d_2 mm	a mm			ID	ID	ID
10	32	4.82	70	15		6	4.9	3	4.1	● 174976	● 188175	● 199042
1/4	28	6.35	80	15	23	7	5.5	3	5.55	● 175993	● 199046	● 199043
5/16	24	7.93	90	18	29	8	6.2	3	7	● 175995	● 199047	● 199044
3/8	24	9.52	100	20	33	10	8	3	8.6	● 175997	● 199048	● 199045

		N						
Характеристики Characteristics								
Типы отверстий Hole type								
		N310-3	N320-3 N320-4	N320V-3 N320V-4	N320TN-3/-4 N320TC-3/-4	N321-3 N321-4	N330-3 N330-4	N330V-3 N330V-4
Длинный по DIN DIN long	DIN 371	60 / 62	62 / 64	60 / 64	64	70	70	70
Особо длинный Extra-long	DC							
Короткий по ISO ISO short	ISO 529							
Короткий по DIN DIN short	DIN 352							
Класс точности Tolerance	ISO 2 6H	60 / 62	62 / 64	60 / 64	64	70	70	70
Увеличенный Oversize	ISO 3 6G		68	68				
Увеличенный Oversize	7G		68					
Увеличенный Oversize	+ 0.10 mm + 0.20 mm		68					
Повышенный класс точности Fine tolerance	ISO 1 4H		66					
Левая резьба LH Left-hand thread	ISO 2 6H	62	66	66				
		N410-3	N420-4	N420V-4	N420TN-4 N420TC-4	N421-4	N430-4	N430V-4
Длинный по DIN DIN long	DIN 376	63	65	65	65	71	71	71
Особо длинный Extra-long	DC							
Короткий по ISO ISO short	ISO 529							
Короткий по DIN DIN short	DIN 352							
Класс точности Tolerance	ISO 2 6H	63	65	65	65	71	71	71
Увеличенный Oversize	ISO 3 6G		69	69				
Увеличенный Oversize	7G		69					
Увеличенный Oversize	+ 0.10 mm + 0.20 mm		69 / 71					
Повышенный класс точности Fine tolerance	ISO 1 4H		67					
Левая резьба LH Left-hand thread	ISO 2 6H	63	67	67				







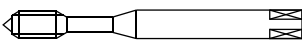
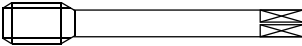























Указатель — Машинные метчики ISO DIN 13
 Directory — Machine taps ISO DIN 13











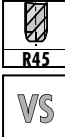
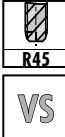

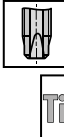
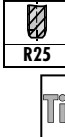

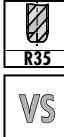



N								
 R15	 R40	 R40	 R40	 R40	 V	 R40	 R40	 V
 V		 V	TiN TiCN	 E 1.5xP	 R40	 R40	 V	 V
N350-3 N350V-3	N360-3	N360V-3	N360TN-3 N360TC-3	N360-5 N360V-5	N361-3	N362V-3	N520-4	N520V-4
72	74	60 / 74	74	80	80	80	82	82
72	74	60 / 74	74	80	80	80	82	82
	76	76						
	78	78						
	78	78						
	78							
	76	76						
N450-3 N450V-3	N460-3	N460V-3	N460TN-3 N460TC-3	N460-5 N460V-5	N461-3	N462V-3	N620-4	N620V-4
73	75	75	75	81	81	81	83	83
73	75	75	75	81	81	81	83	83
	77	77						
	79	79						
	79	79						
	79							
	77	77						

		N								
Характеристики Characteristics		 TiN	 R40	 R40	 V	 R40	 TiN		 R40	
										
Типы отверстий Hole type										
		N520TN-4	N560-3	N560V-3	N560TN-3	N1120-4	N1160-3	N1110 -1 -2 -3 -S		
Длинный по DIN DIN long	DIN 371									
Особо длинный Extra-long	DC	82	84	84	84					
Короткий по ISO ISO short	ISO 529					118	118	60 / 114		
Короткий по DIN DIN short	DIN 352									
Класс точности Tolerance	ISO 2 6H	82	84	84	84	118	118	60 / 114		
Увеличенный Oversize	ISO 3 6G									
Увеличенный Oversize	7G									
Увеличенный Oversize	+ 0.10 mm + 0.20 mm									
Повышенный класс точности Fine tolerance	ISO 1 4H									
Левая резьба LH Left-hand thread	ISO 2 6H									
		N620TN-4	N660-3	N660V-3	N660TN-3	N1220-4	N1260-3	N1210 -1 -2 -3 -S		
Длинный по DIN DIN long	DIN 376									
Особо длинный Extra-long	DC	83	85	85	85					
Короткий по ISO ISO short	ISO 529					118	118	60 / 115		
Короткий по DIN DIN short	DIN 352									
Класс точности Tolerance	ISO 2 6H	83	85	85	85	118	118	60 / 115		
Увеличенный Oversize	ISO 3 6G									
Увеличенный Oversize	7G									
Увеличенный Oversize	+ 0.10 mm + 0.20 mm									
Повышенный класс точности Fine tolerance	ISO 1 4H									
Левая резьба LH Left-hand thread	ISO 2 6H									



Указатель — Машинные и ручные метчики ISO DIN 13
 Directory — Machine and hand taps ISO DIN 13



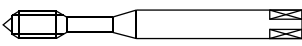
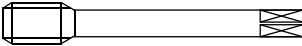



























N	W				Z			
 		 DLC	 R40	 R40 DLC	 V	 VS	 R40 V	 R40 VS
								
								
NP110-S -1 -2 -3 -S	W320-3 W320-4	W320DL-3 W320DL-4	W360-3	W360DL-3	Z320V-3 Z320V-4	Z320VS-4	Z360V-3 Z362V-3	Z360VS-3 Z362VS-3
	86	86	87	87	88	88	89	90
116								
116	86	86	87	87	88	88	89	90
NP210-S -1 -2 -3 -S	W420-4	W420DL-4	W460-3	W460DL-3	Z420V-4	Z420VS-4	Z462V-3	Z462VS-3
	86	86	87	87	88	88	89	91
117								
117	86	86	87	87	88	88	89	91

	Z		ZX	H		S	
Характеристики Characteristics							
							
Типы отверстий Hole type							
	Z370VS-3	Z373VS-3	ZX320-4	H320-4 H320TC-4	H350-3 H350TC-3	S320VS-4	S360VS-3
Длинный по DIN DIN long	DIN 371						
Особо длинный Extra-long	DC						
Короткий по ISO ISO short	ISO 529						
Короткий по DIN DIN short	DIN 352						
Класс точности Tolerance	ISO 2 6H						
Увеличенный Oversize	ISO 3 6G						
Увеличенный Oversize	7G						
Увеличенный Oversize	+ 0.10 mm + 0.20 mm						
Повышенный класс точности Fine tolerance	ISO 1 4H						
Левая резьба LH Left-hand thread	ISO 2 6H						
	Z470VS-3	Z473VS-3	ZX420-4	H420-4 H420TC-4	H450-3 H450TC-3	S420VS-4	S460VS-3
Длинный по DIN DIN long	DIN 376						
Особо длинный Extra-long	DC						
Короткий по ISO ISO short	ISO 529						
Короткий по DIN DIN short	DIN 352						
Класс точности Tolerance	ISO 2 6H						
Увеличенный Oversize	ISO 3 6G						
Увеличенный Oversize	7G						
Увеличенный Oversize	+ 0.10 mm + 0.20 mm						
Повышенный класс точности Fine tolerance	ISO 1 4H						
Левая резьба LH Left-hand thread	ISO 2 6H						





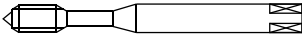





















Указатель — Машинные метчики ISO DIN 13
Directory — Machine taps ISO DIN 13

SA			TL		GG			
SA320-4	SA350-3	SA390-3	TL320VS-4	TL351VS-3	GG350NV-3	GG350TC-3	GG353TC-3	GG550NV-3
100	100	99	100	100	102	102	102	102
								102
100	100	99	100	100	102	102	102	102
100	100	99	100	100				
SA420-4	SA450-3		TL420VS-4	TL451VS-3	GG450NV-3	GG450TC-3	GG453TC-3	GG650NV-3
101	101		101	101	103	103	103	103
								103
101	101		101	101	103	103	103	103
101	101		101	101				













	K			QTAP			
Характеристики Characteristics							
							
							
				NEW	NEW	NEW	NEW
Типы отверстий Hole type							
	K313TC-3			Q320VS-4	Q323VS-4	Q360VS-3	Q363VS-3
Длинный по DIN DIN long	DIN 371			61 / 106	106	61 / 107	107
Особо длинный Extra-long	DC						
Короткий по ISO ISO short	ISO 529						
Короткий по DIN DIN short	DIN 352						
Класс точности Tolerance	ISO 2 6H	104		61 / 106	106	61 / 107	107
Увеличенный Oversize	ISO 3 6G						
Увеличенный Oversize	7G						
Увеличенный Oversize	+ 0.10 mm + 0.20 mm						
Повышенный класс точности Fine tolerance	ISO 1 4H						
Левая резьба LH Left-hand thread	ISO 2 6H						
	K413TC-3	K613TC-3	K613VS-3	Q420VS-4	Q423VS-4	Q460VS-3	Q463VS-3
Длинный по DIN DIN long	DIN 376	104		106	106	107	107
Особо длинный Extra-long	DC		105				
Короткий по ISO ISO short	ISO 529						
Короткий по DIN DIN short	DIN 352						
Класс точности Tolerance	ISO 2 6H	104	105	106	106	107	107
Увеличенный Oversize	ISO 3 6G						
Увеличенный Oversize	7G						
Увеличенный Oversize	+ 0.10 mm + 0.20 mm						
Повышенный класс точности Fine tolerance	ISO 1 4H						
Левая резьба LH Left-hand thread	ISO 2 6H						



Указатель — Машинные метчики ISO DIN 13
Directory — Machine taps ISO DIN 13









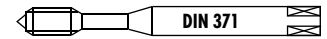





RTS							
 VS	 VS	 R40 VS	 R40 VS	 R40 E 1.5xP VS	 R40 E 1.5xP VS	 VS	 R40 VS
							
							
RTS320VS-4	RTS323VS-4	RTS360VS-3 RTS362VS-3	RTS365VS-3	RTS362VS-5	RTS365VS-5	RTS523VS-4	RTS565VS-3
108	108	109	109	111	111	112	112
108	108	109	109	111	111	112	112
		110					
		110					
RTS420VS-4	RTS423VS-4	RTS462VS-3	RTS465VS-3			RTS623VS-4	RTS665VS-3
108	108	109	109			112	112
108	108	109	109			112	112
		110					
		110					











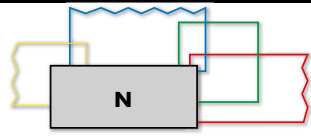



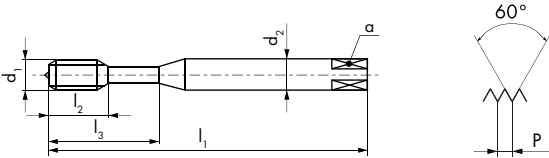



Наборы метчиков
Tap assortments

BOXSET	D5855	D5860	D5891
<p>D5855  ISO 2 6H N1110-S M3, M4, M5, M6, M8, M10, N1210-S M12</p> <p>D5860  ISO 2 6H N1110-S M3, M4, M5, M6, M8, M10, N1210-S M12  HSS FO DIN 338 D2.5, 3.3, 4.2, 5.0, FO DIN 338 6.8, 8.5, 10.2</p> <p>D5891  ISO 2 6H N310-3 M3, M4, M5, M6, M8, M10, N410-3 M12</p>			
<p>No D5855 / D5860 / D5891</p>	<p>ID</p>	<p>ID</p>	<p>ID</p>
<p>M3 - M12</p>	<p>● 118728</p>	<p>● 118733</p>	<p>● 170922</p>
<p>BOXSET</p>	<p>D5892</p>		
<p>D5892   ISO 2 6H N320V-4 M3, M4, M5, M6, M8, M10</p>			
<p>No D5892</p>	<p>ID</p>		
<p>M3 - M10</p>	<p>● 170921</p>		
<p>BOXSET</p>	<p>D5896</p>		
<p>D5896  R40  ISO 2 6H N360V-3 M3, M4, M5, M6, M8, M10  V <2.5 x D</p>			
<p>No D5896</p>	<p>ID</p>		
<p>M3 - M10</p>	<p>● 167599</p>		

Наборы метчиков — QTAP
Tap assortments — QTAP



BOXSET	D5893
<p>Q320VS-4</p>      <p>M3, M4, M5 M6, M8, M10</p>	  <p>NEW</p>
No D5893	ID
M3 - M10	● 197104
BOXSET	D5897
<p>Q360VS-3</p>      <p>M3, M4, M5 M6, M8, M10</p>	  <p>NEW</p>
No D5897	ID
M3 - M10	● 197105

										N310-3	N310-3 LH	N320-3
										N310-3  31 62 73 74 91	 LH 31 62 73 74 91	 62 63 64 72 73 74 81 91
			  	  								
Ø d ₁ M	P mm	l ₁ mm	l ₂ mm	l ₃ mm	d ₂ mm	a mm			ID	ID	ID	
1	0.25	40	5.5		2.5	2.1	3	0.75	● 150167			
1.1	0.25	40	5.5		2.5	2.1	3	0.85	● 174745			
1.2	0.25	40	5.5		2.5	2.1	3	0.95	● 150168			
1.4	0.3	40	7		2.5	2.1	3	1.1	● 150169			
1.5	0.3	40	7		2.5	2.1	3	1.2	● 174752			
1.6	0.35	40	8		2.5	2.1	3	1.25	● 174753			
1.7	0.35	40	8		2.5	2.1	3	1.35	● 174754			
1.8	0.35	40	8		2.5	2.1	3	1.45	● 174755			
2	0.4	45	8		2.8	2.1	3	1.6	● 101439	● 111460		
2.2	0.45	45	9		2.8	2.1	3	1.75	● 174756			
2.3	0.4	45	9		2.8	2.1	3	1.9	● 174757			
2.5	0.45	50	10		2.8	2.1	3	2.05	● 101440	● 111461		
2.6	0.45	50	10		2.8	2.1	3	2.15	● 101441			
3	0.5	56	12	18	3.5	2.7	3	2.5	● 101442	● 111462		
3.5	0.6	56	13	20	4	3	3	2.9	● 101443			
4	0.7	63	14	21	4.5	3.4	3	3.3	● 101444	● 111464		
5	0.8	70	15	25	6	4.9	* 3	4.2	● 101445	● 111465	* 101465	
6	1	80	17	30	6	4.9	* 3	5	● 101446	● 111466	* 101466	
8	1.25	90	20	35	8	6.2	3	6.8	● 101447			
10	1.5	100	22	39	10	8	3	8.5	● 101438			
*N320-3 =  2										 ≤ M1.5		

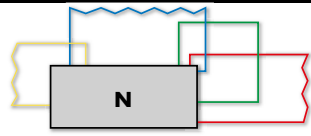



N410-3  **31** **62** **73** **74** **91**



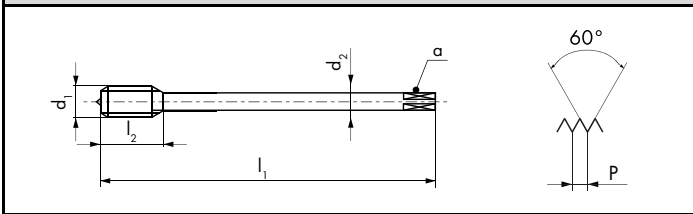







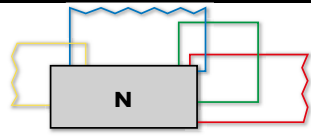

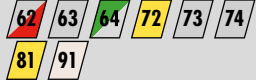

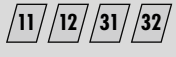



N410-3 LH  **LH** **31** **62** **73** **74** **91**

N410-3	N410-3 LH		
--------	-----------	--	--

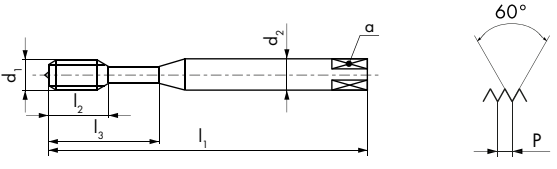





C **2.5 x P** **ISO 2 6H**

$\emptyset d_1$ M	P mm	l_1 mm	l_2 mm	d_2 mm	a mm			ID	ID
3	0.5	56	12	2.2	1.8	3	2.5	● 101897	
4	0.7	63	14	2.8	2.1	3	3.3	● 101924	
5	0.8	70	15	3.5	2.7	3	4.2	● 101942	
6	1	80	17	4.5	3.4	3	5	● 101953	
7	1	80	17	5.5	4.3	3	6	● 142645	● 111491
8	1.25	90	20	6	4.9	3	6.8	● 101958	● 111492
10	1.5	100	22	7	5.5	3	8.5	● 101866	● 111478
12	1.75	110	24	9	7	3	10.2	● 101870	● 111479
14	2	110	28	11	9	3	12	● 101874	● 111480
16	2	110	30	12	9	3	14	● 101880	● 111481
18	2.5	125	33	14	11	3	15.5	● 101883	● 111482
20	2.5	140	36	16	12	3	17.5	● 101885	● 125530
22	2.5	140	36	18	14.5	3	19.5	★ 101888	
24	3	160	39	18	14.5	4	21	● 101891	● 111485
27	3	160	42	20	16	4	24	● 101895	● 111486
30	3.5	180	45	22	18	4	26.5	● 101901	● 111487
33	3.5	180	48	25	20	4	29.5	★ 101907	
36	4	200	51	28	22	4	32	● 101915	● 111488
39	4	200	55	32	24	4	35	● 101922	
42	4.5	200	55	32	24	4	37.5	● 101932	
48	5	250	63	36	29	4	43	● 111489	
56	5.5	280	71	45	35	5	50.5	● 111447	

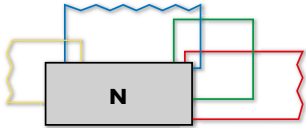
										N320-4	N320V-4	N320TN-4	N320TC-4				
																	
N320-4																	
N320V-4	 V																
N320TN-4	 TiN																
N320TC-4	 TiCN																
																	
Ø d ₁ M	P mm	l ₁ mm	l ₂ mm	l ₃ mm	d ₂ mm	a mm			ID	ID	ID	ID					
* 1	0.25	40	5.5		2.5	2.1	2	0.75	● 111467								
* 1.1	0.25	40	5.5		2.5	2.1	2	0.85	● 111468								
* 1.2	0.25	40	5.5		2.5	2.1	2	0.95	● 111469								
* 1.4	0.3	40	7		2.5	2.1	2	1.1	● 111470								
* 1.5	0.3	40	7		2.5	2.1	2	1.2	● 111471								
* 1.6	0.35	40	8		2.5	2.1	2	1.25	● 101454								
* 1.7	0.35	40	8		2.5	2.1	2	1.35	● 101455								
* 1.8	0.35	40	8		2.5	2.1	2	1.45	● 101456								
* 2	0.4	45	8		2.8	2.1	2	1.6	● 101458	● 101536	● 101528	● 152900					
* 2.2	0.45	45	9		2.8	2.1	2	1.75	● 101459								
* 2.3	0.4	45	9		2.8	2.1	2	1.9	● 101460								
2.5	0.45	50	10		2.8	2.1	3	2.05	● 101483	● 101545	● 101530	● 101522					
2.6	0.45	50	10		2.8	2.1	3	2.15	● 101484								
3	0.5	56	12	18	3.5	2.7	3	2.5	● 101485	● 101546	● 101531	● 101523					
3.5	0.6	56	13	20	4	3	3	2.9	● 101491	● 101547							
4	0.7	63	14	21	4.5	3.4	3	3.3	● 101495	● 101548	● 101532	● 101524					
5	0.8	70	15	25	6	4.9	3	4.2	● 101499	● 101549	● 101533	● 101525					
6	1	80	17	30	6	4.9	3	5	● 101503	● 101550	● 101534	● 101526					
8	1.25	90	20	35	8	6.2	3	6.8	● 101506	● 101551	● 101535	● 101527					
10	1.5	100	22	39	10	8	3	8.5	● 101481	● 101544	● 101529	● 101521					
*N320-3 / N320V-3 N320TN-3 / N320TC-3 																	







									N420-4	N420V-4	N420TN-4	N420TC-4
N420-4												
N420V-4		V										
N420TN-4		TiN										
N420TC-4		TiCN										
$\emptyset d_1$ M	P mm	l_1 mm	l_2 mm	d_2 mm	a mm				ID	ID	ID	ID
3	0.5	56	12	2.2	1.8	3	2.5	● 102119	● 143418			
4	0.7	63	14	2.8	2.1	3	3.3	● 102146	● 102279			
5	0.8	70	15	3.5	2.7	3	4.2	● 102171	● 102280	● 146297		
6	1	80	17	4.5	3.4	3	5	● 102182	● 102282	● 147439		
7	1	80	17	5.5	4.3	3	6	● 102189	● 144713			
8	1.25	90	20	6	4.9	3	6.8	● 102195	● 102285	● 102251	● 102233	
9	1.25	90	20	7	5.5	3	7.8	● 102202				
10	1.5	100	22	7	5.5	3	8.5	● 102061	● 102263	● 102240	● 102228	
11	1.5	100	19	8	6.2	3	9.5	● 162770				
12	1.75	110	24	9	7	3	10.2	● 102072	● 102265	● 102243	● 102229	
14	2	110	28	11	9	3	12	● 102081	● 102267	● 102245		
16	2	110	30	12	9	3	14	● 102090	● 102269	● 102247	● 102231	
18	2.5	125	33	14	11	3	15.5	● 102097	● 102271			
20	2.5	140	36	16	12	3	17.5	● 102101	● 102273	● 102248	● 102232	
22	2.5	140	36	18	14.5	3	19.5	● 102106	● 102275			
24	3	160	39	18	14.5	4	21	● 102110	● 102278	● 144220	● 163736	
27	3	160	42	20	16	4	24	● 102117	● 143856			
30	3.5	180	45	22	18	4	26.5	● 102124	● 105124			
33	3.5	180	48	25	20	4	29.5	● 102130	● 146968			
36	4	200	51	28	22	4	32	● 102137	● 143430			
39	4	200	55	32	24	4	35	● 102144	● 158724			
42	4.5	200	55	32	24	4	37.5	● 102158	● 143107			
45	4.5	220	59	36	29	4	40.5	● 110225	● 159565			
48	5	250	63	36	29	4	43	● 110226	● 157517			
56	5.5	280	71	45	35	5	50.5	● 110229	● 158178			

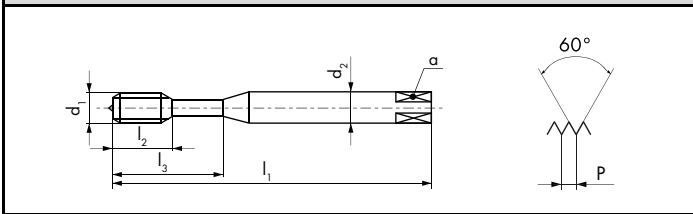
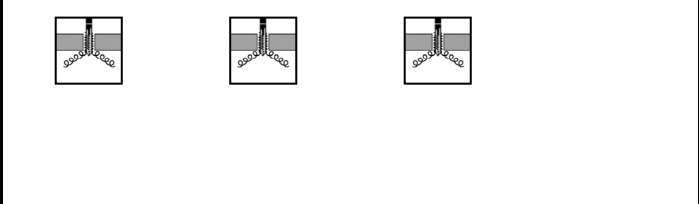



N320-4			62 63 64 72 73 74 81 91
N320-4 LH		LH	62 63 64 72 73 74 81 91
N320V-4 LH		V LH	11 12 31 32

N320-4	N320-4 LH	N320V-4 LH	
--------	-----------	------------	--



		
		

Ø d ₁ M	P mm	l ₁ mm	l ₂ mm	l ₃ mm	d ₂ mm	a mm			ID	ID	ID
* 2	0.4	45	8		2.8	2.1	2	1.6	● 162503	● 111472	● 162771
2.5	0.45	50	10		2.8	2.1	3	2.05	● 159345		
3	0.5	56	12	18	3.5	2.7	3	2.5	● 101487	● 111473	● 162772
4	0.7	63	14	21	4.5	3.4	3	3.3	● 101493	● 111474	● 162773
5	0.8	70	15	25	6	4.9	3	4.2	● 101497	● 111475	● 162774
6	1	80	17	30	6	4.9	3	5	● 101501	● 111476	● 162775
10	1.5	100	22	39	10	8	3	8.5	★ 146484		

*N320-3 / N320V-3 

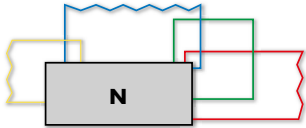

N420-4			62 63 64 72 73 74 81 91
N420-4 LH		LH	62 63 64 72 73 74 81 91
N420V-4 LH		V LH	11 12 31 32

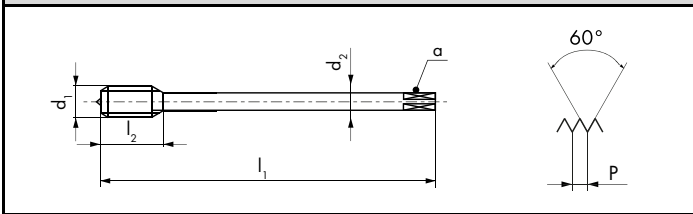
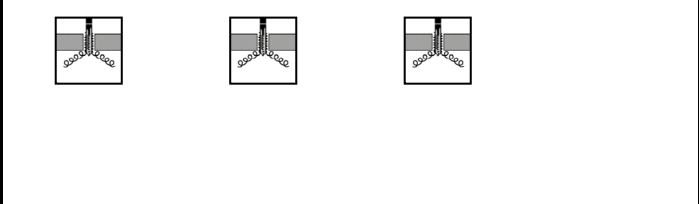









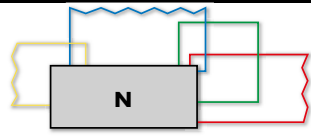









ISO 1 4H	ISO 2 6H	ISO 2 6H

$\emptyset d_1$ M	P mm	l_1 mm	l_2 mm	d_2 mm	a mm		
8	1.25	90	20	6	4.9	3	^6.8
10	1.5	100	22	7	5.5	3	8.5
12	1.75	110	24	9	7	3	10.2
14	2	110	28	11	9	3	12
16	2	110	30	12	9	3	14
20	2.5	140	36	16	12	3	17.5
24	3	160	39	18	14.5	4	21

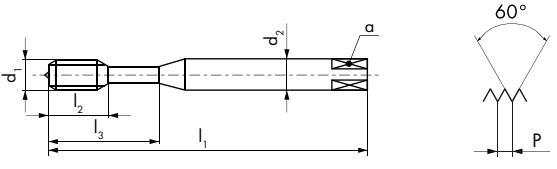
ID	ID	ID
● 102193	● 102198	● 142621
● 102059	● 102064	● 143287
● 102070	● 102040	● 146583
	● 102084	● 146563
	● 102093	● 143108
	● 102103	● 145579
	● 111493	● 145578

Δ ISO 1 4H = 6.70





									N320-4	N320V-4	N320-4	N320-4			
															
N320-4															
N320V-4															
															
															
Ø d ₁ M	P mm	l ₁ mm	l ₂ mm	l ₃ mm	d ₂ mm	a mm			ID	6H + mm	ID	6H + mm	ID	6H + mm	ID
* 2	0.4	45	8		2.8	2.1	2	1.6	● 101457	0.019	● 143584	0.019			
2.5	0.45	50	10		2.8	2.1	3	2.05	● 101482	0.020	● 150522	0.020			
3	0.5	56	12	18	3.5	2.7	3	2.5	● 101486	0.020	● 143116	0.020	● 101489	0.036	● 101488
3.5	0.6	56	13	20	4	3	3	2.95	● 101490	0.021					
4	0.7	63	14	21	4.5	3.4	3	3.35	● 101494	0.022	● 143087	0.022	● 101496	0.041	● 111522
5	0.8	70	15	25	6	4.9	3	4.25	● 101498	0.024	● 143088	0.024	● 101500	0.044	● 111523
6	1	80	17	30	6	4.9	3	5	● 101502	0.026	● 143089	0.026	● 101504	0.050	● 111524
8	1.25	90	20	35	8	6.2	3	6.8	● 101505	0.028	● 143604	0.028			

*N320-3 / N320V-3

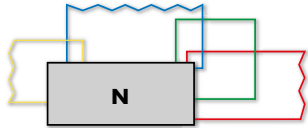





								N420-4	N420V-4	N420-4	N420-4			
N420-4		62	63	64	72	73	74							
N420V-4		81	91											
		11	12	31	32									
$\emptyset d_1$ M	P mm	l_1 mm	l_2 mm	d_2 mm	a mm			ID	6H + mm	ID	6H + mm	ID	6H + mm	ID
8	1.25	90	20	6	4.9	3	6.8	● 102194	0.028	● 145246	0.028	● 102199	0.052	● 102196
10	1.5	100	22	7	5.5	3	8.5	● 102060	0.032	● 143726	0.032	● 102065	0.060	● 102062
12	1.75	110	24	9	7	3	10.3	● 102071	0.034	● 145655	0.034	● 102076	0.066	● 102073
16	2	110	30	12	9	3	14	● 135531	0.038	● 162795	0.038	● 102094	0.072	● 102091



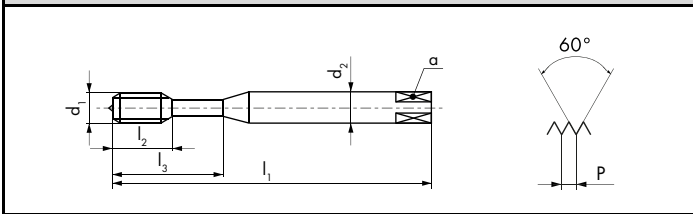
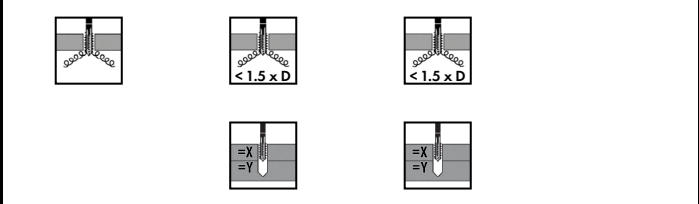

N321-4			61 62 63 64 71 72 73 74 81 91
N330-4			63 72
N330V-4			11 12

N321-4	N330-4	N330V-4	
--------	--------	---------	--





		
B 4 x P	B 4 x P	B 4 x P
ISO 2 6H	ISO 2 6H	ISO 2 6H

$\varnothing d_1$ M	P mm	l_1 mm	l_2 mm	l_3 mm	d_2 mm	a mm		
* 1	0.25	40	5.5		2.5	2.1	2	0.75
* 1.1	0.25	40	5.5		2.5	2.1	2	0.85
* 1.2	0.25	40	5.5		2.5	2.1	2	0.95
* 1.4	0.3	40	7		2.5	2.1	2	1.1
* 1.6	0.35	40	8		2.5	2.1	2	1.25
* 2	0.4	45	8		2.8	2.1	2	1.6
2.5	0.45	50	10		2.8	2.1	* 3	2.05
3	0.5	56	12	18	3.5	2.7	* 3	2.5
3.5	0.6	56	13	20	4	3	2	2.9
4	0.7	63	14	21	4.5	3.4	3	3.3
5	0.8	70	15	25	6	4.9	3	4.2
6	1	80	17	30	6	4.9	3	5

ID	ID	ID
	● 101558	
	★ 101559	
	● 101560	
	● 101561	
	● 101562	● 151246
● 101552	● 105125	● 101572
● 101553	● 101565	● 101573
● 101555	● 101567	● 101574
	● 101568	
● 101557	● 101569	● 101576
	● 101570	● 101577
	● 101571	● 101578

*N320-3 / N320V-3 / N330V-3 

* N330-4 =  2
* N330V-4 =  2

≤ M1.5 

								N420-4	N421-4	N430-4	N430V-4
N420-4											
N421-4											
N430-4											
N430V-4											
$\emptyset d_1$ M	P mm	l_1 mm	l_2 mm	d_2 mm	a mm			ID	ID	ID	ID
4	0.7	63	14	2.8	2.1	3	3.3		● 102293		
5	0.8	70	15	3.5	2.7	3	4.2		● 102294		
6	1	80	17	4.5	3.4	3	5		● 102295		
8	1.25	90	20	6	4.9	3	6.8	● 102197	● 102296	● 102301	● 102306
10	1.5	100	22	7	5.5	3	8.5	● 102063	● 102286	● 102297	● 102302
12	1.75	110	24	9	7	3	10.2	● 102074	● 102287	● 102298	● 102303
16	2	110	30	12	9	3	14	● 102092	● 102289		

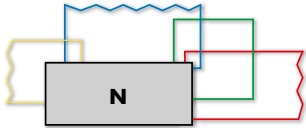

N350-3



62 63 64 72 73 74
81 91

N350V-3

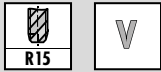



11 12 31 32

N350-3

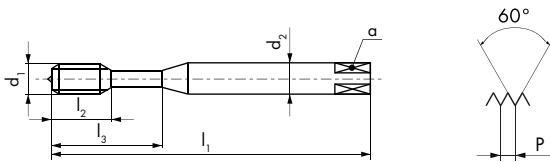
N350V-3



Ø d ₁ M	P mm	l ₁ mm	l ₂ mm	l ₃ mm	d ₂ mm	a mm		
2	0.4	45	8		2.8	2.1	2	1.6
2.3	0.4	45	9		2.8	2.1	2	1.9
2.5	0.45	50	10		2.8	2.1	2	2.05
2.6	0.45	50	10		2.8	2.1	2	2.15
3	0.5	56	12	18	3.5	2.7	2	2.5
3.5	0.6	56	13	20	4	3	2	2.9
4	0.7	63	14	21	4.5	3.4	2	3.3
5	0.8	70	15	25	6	4.9	3	4.2
6	1	80	17	30	6	4.9	3	5
8	1.25	90	20	35	8	6.2	3	6.8
10	1.5	100	22	39	10	8	3	8.5

ID

ID

● 101580	● 101593
● 101581	
● 101582	● 101594
● 101583	
● 101584	● 101595
● 101585	
● 101587	● 101596
● 101589	● 101597
● 101591	● 101598
● 101592	● 146810
● 101579	● 147217

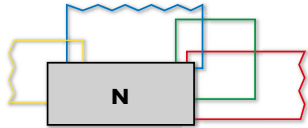

N450-3

R15

62 63 64 72 73 74
81 91

N450V-3

R15

V

11 12 31 32



< 1.5 x D

< 1.5 x D

< 2.5 x D

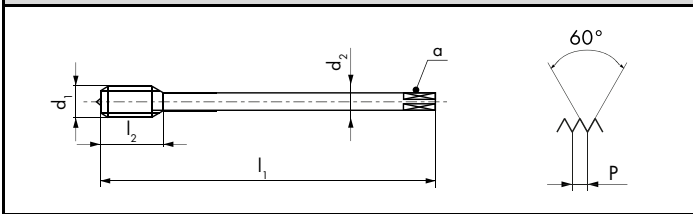



C 2.5 x P

C 2.5 x P

ISO 2 6H

ISO 2 6H

$\emptyset d_1$ M	P mm	l_1 mm	l_2 mm	d_2 mm	a mm			ID	ID
8	1.25	90	20	6	4.9	3	6.8	● 102327	● 102334
10	1.5	100	22	7	5.5	3	8.5	● 102314	● 102329
12	1.75	110	24	9	7	3	10.2	● 102317	● 102330
14	2	110	28	11	9	3	12	● 102319	● 145487
16	2	110	30	12	9	3	14	● 102321	● 102331
20	2.5	140	36	16	12	4	17.5	● 102324	● 102332
24	3	160	39	18	14.5	4	21	● 102325	● 102333

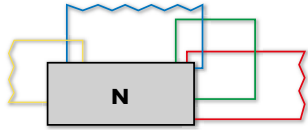

N360-3		63 72 73 74 81 91
N360V-3		11 12 32
N360TN-3		11 12 13 14 32
N360TC-3		11 12 13 14 21 31 32 62 64 73 74 82 83

N360-3	N360V-3	N360TN-3	N360TC-3
--------	---------	----------	----------



--	--	--	--

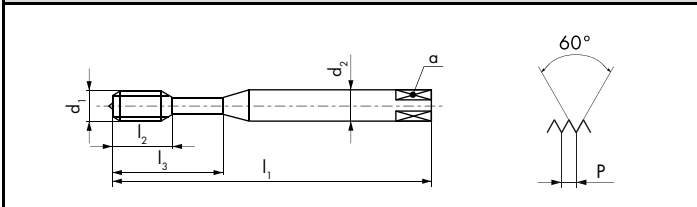

Ø d ₁ M	P mm	l ₁ mm	l ₂ mm	l ₃ mm	d ₂ mm	a mm			ID	ID	ID	ID
2	0.4	45	7		2.8	2.1	2	1.6	● 101618	● 101708	● 101697	● 146842
2.2	0.45	45	8		2.8	2.1	2	1.75	● 101619			
2.3	0.4	45	8		2.8	2.1	2	1.9	● 101620			
2.5	0.45	50	9		2.8	2.1	2	2.05	● 101622	● 101709	● 101698	● 101689
2.6	0.45	50	9		2.8	2.1	2	2.15	● 101623	● 101710		
3	0.5	56	5.5	18	3.5	2.7	3	2.5	● 101626	● 101711	● 101699	● 101690
3.5	0.6	56	6.5	20	4	3	3	2.9	● 101630	● 142625		
4	0.7	63	7.5	21	4.5	3.4	3	3.3	● 101635	● 101713	● 101700	● 101691
4.5	0.75	70	9	25	6	4.9	3	3.75	● 101639			
5	0.8	70	9	25	6	4.9	3	4.2	● 101644	● 101715	● 101701	● 101692
6	1	80	11	30	6	4.9	3	5	● 101652	● 101717	● 101703	● 101693
7	1	80	11	30	7	5.5	3	6	● 101656	● 101718		
8	1.25	90	12.5	35	8	6.2	3	6.8	● 101663	● 101721	● 101705	● 101694
9	1.25	90	12.5	35	9	7	3	7.8	● 101668			
10	1.5	100	14	39	10	8	3	8.5	● 101612	● 101707	● 101696	● 101688

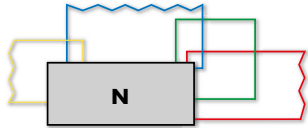

	N460-3	N460V-3	N460TN-3	N460TC-3
N460-3	R40			
	63 72 73 74 81 91			
N460V-3	R40	V		
	11 12 32			
N460TN-3	R40	TiN		
	11 12 13 14 32			
N460TC-3	R40	TiCN		
	11 12 13 14 21 31 32 62 64 73 74 82 83			





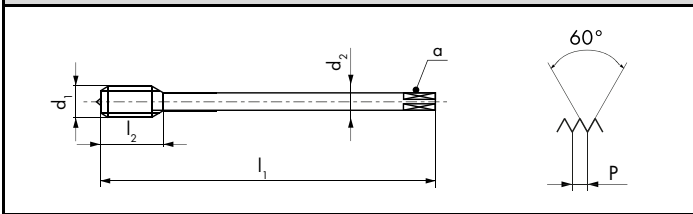



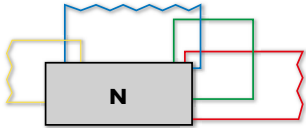

< 2.5 x D	< 2.5 x D	< 2.5 x D	< 2.5 x D
-----------	-----------	-----------	-----------







C 2.5 x P	C 2.5 x P	C 2.5 x P	C 2.5 x P
ISO 2 6H	ISO 2 6H	ISO 2 6H	ISO 2 6H







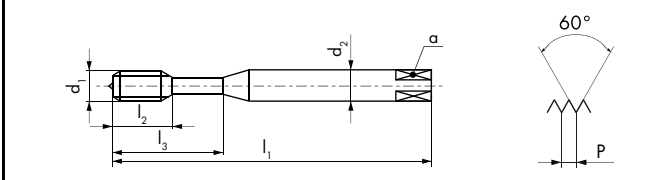

$\emptyset d_1$ M	P mm	l_1 mm	l_2 mm	d_2 mm	a mm			ID	ID	ID	ID
5	0.8	70	9	3.5	2.7	3	4.2	● 102410	● 102489	● 160682	
6	1	80	11	4.5	3.4	3	5	● 102411	● 102491	● 152850	
8	1.25	90	12.5	6	4.9	3	6.8	● 102412	● 102492	● 152849	
10	1.5	100	14	7	5.5	3	8.5	● 102351	● 102461	● 150242	● 158687
12	1.75	110	14	9	7	3	10.2	● 102359	● 102465	● 102449	● 102438
14	2	110	14	11	9	3	12	● 102369	● 102468	● 102451	● 111615
16	2	110	18	12	9	3	14	● 102376	● 102471	● 102453	● 102440
18	2.5	125	21	14	11	3	15.5	● 102383	● 102473		
20	2.5	140	24	16	12	4	17.5	● 102389	● 102475	● 102454	● 143280
22	2.5	140	24	18	14.5	4	19.5	● 102394	● 102477		
24	3	160	27	18	14.5	4	21	● 102398	● 102480	● 143119	● 150018
27	3	160	27	20	16	4	24	● 175423	● 102481		
30	3.5	180	30	22	18	4	26.5	● 150246	● 102482		
33	3.5	180	33	25	20	4	29.5	● 167621	● 102483		
36	4	200	36	28	22	5	32	● 143914	● 102484		
39	4	200	40	32	24	5	35	● 175424	● 102485		
42	4.5	200	40	32	24	5	37.5	● 169122	● 102486		
45	4.5	220	44	36	29	5	40.5		● 102487		
48	5	250	48	36	29	5	43		● 102488		
52	5	250	52	40	32	5	47		● 110228		
56	5.5	280	56	45	35	6	50.5		● 102490		
64	6	315	64	50	39	6	58		● 143805		





N360-3 LH			63 72 73 74 81 91	
N360V-3 LH				11 12 32
N360-3			63 72 73 74 81 91	
N360V-3			11 12 32	

N360-3 LH	N360V-3 LH	N360-3	N360V-3
			
			



Ø d ₁ M	P mm	l ₁ mm	l ₂ mm	l ₃ mm	d ₂ mm	a mm			ID	ID	ID ^{6H} + mm	ID ^{6H} + mm
2	0.4	45	7		2.8	2.1	2	1.6			● 101617 0.019	● 146000 0.019
2.5	0.45	50	9		2.8	2.1	2	2.05			● 101621 0.020	● 143294 0.020
3	0.5	56	5.5	18	3.5	2.7	3	2.5	● 101627	● 146811	● 101625 0.020	● 104816 0.020
3.5	0.6	56	6.5	20	4	3	3	2.95			● 101629 0.021	● 125829 0.021
4	0.7	63	7.5	21	4.5	3.4	3	3.3	● 101637	● 162540	● 101634 0.022	● 104817 0.022
5	0.8	70	9	25	6	4.9	3	4.2	● 101646	● 144003	● 101643 0.024	● 104818 0.024
6	1	80	11	30	6	4.9	3	5	● 101654	● 144004	● 101669 0.026	● 104819 0.026
8	1.25	90	12.5	35	8	6.2	3	6.8	● 101666	● 143925	● 101662 0.028	● 104820 0.028
10	1.5	100	14	39	10	8	3	8.5	● 101615	● 143587	● 101611 0.032	● 104821 0.032

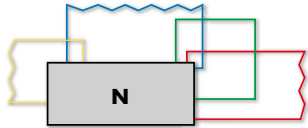

								N460-3 LH	N460V-3 LH	N460-3	N460V-3
<p>N460-3 LH LH 63 72 73 74 81 91</p> <p>N460V-3 LH V LH 11 12 32</p> <p>N460-3 63 72 73 74 81 91</p> <p>N460V-3 V 11 12 32</p>											
$\emptyset d_1$ M	P mm	l_1 mm	l_2 mm	d_2 mm	a mm			ID	ID	ID ^{6H} + mm	ID ^{6H} + mm
12	1.75	110	14	9	7	3	10.2	● 102362	● 146354	● 102358 0.034	● 143602 0.034
14	2	110	14	11	9	3	12			● 102368 0.038	● 144712 0.038
16	2	110	18	12	9	3	14	● 102378	● 143439	● 102375 0.038	● 150197 0.038
20	2.5	140	24	16	12	4	17.5	● 102390	● 146564	● 102388 0.042	● 145420 0.042

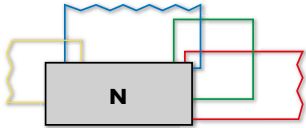

N360-3



63 72 73 74 81 91

N360V-3





11 12 32

N360-3

N360-3

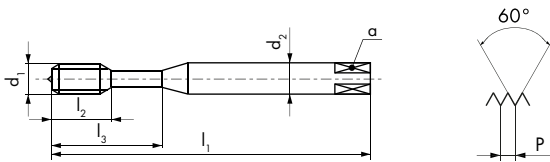
N360V-3





Ø d ₁ M	P mm	l ₁ mm	l ₂ mm	l ₃ mm	d ₂ mm	a mm		 6H
3	0.5	56	5.5	18	3.5	2.7	3	2.5
4	0.7	63	7.5	21	4.5	3.4	3	3.3
5	0.8	70	9	25	6	4.9	3	4.2
6	1	80	11	30	6	4.9	3	5
8	1.25	90	12.5	35	8	6.2	3	^Δ 6.8
10	1.5	100	14	39	10	8	3	8.5

ID	ID 6H + mm	ID 6H + mm
● 101624	● 101628 0.036	● 144311 0.036
● 101633	● 101638 0.041	● 144192 0.041
● 101642	● 101647 0.044	● 143208 0.044
● 101651	● 101655 0.050	● 146709 0.050
● 101661	● 101667 0.052	● 146267 0.052
● 101610	● 101616 0.060	● 142547 0.060

6H
+0.1 mm



6H
+0.1 mm

Ø d ₁ M	P mm	l ₁ mm	l ₂ mm	l ₃ mm	d ₂ mm	a mm		 6H +0.1
3	0.5	56	5.5	18	3.5	2.7	3	2.6
4	0.7	63	7.5	21	4.5	3.4	3	3.4
5	0.8	70	9	25	6	4.9	3	4.3
6	1	80	11	30	6	4.9	3	5.1
8	1.25	90	12.5	35	8	6.2	3	6.9
10	1.5	100	14	39	10	8	3	8.6

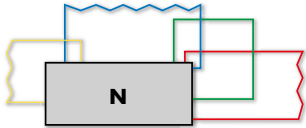

ID	ID
● 160847	
● 101636	● 146513
● 101645	● 146046
● 101653	● 145559
● 101664	● 143415
● 101613	● 124917

^Δ ISO 1 4H = 6.70









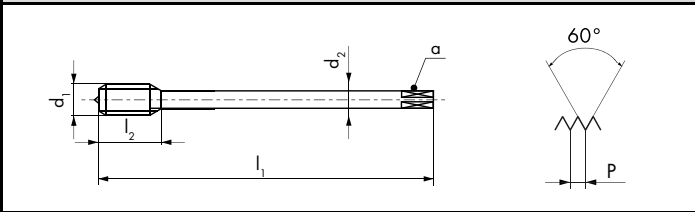

N460-3		63 72 73 74 81 91
N460V-3	 	11 12 32







		
---	---	---



		
		









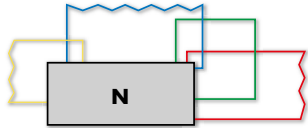

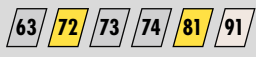



$\emptyset d_1$ M	P mm	l_1 mm	l_2 mm	d_2 mm	a mm		
12	1.75	110	14	9	7	3	10.2
16	2	110	18	12	9	3	14

ID	ID ^{6H} + mm	ID ^{6H} + mm
* 124987	● 102363 0.066	● 142532 0.066
	● 102379 0.072	● 144956 0.072
		





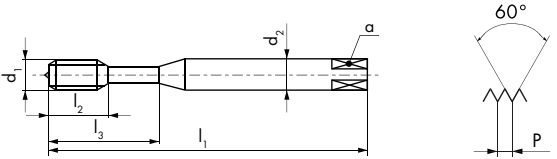
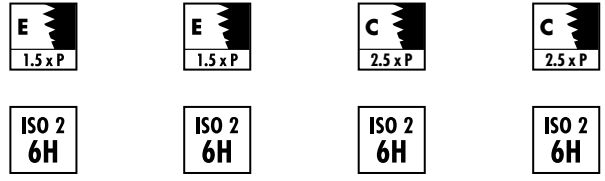



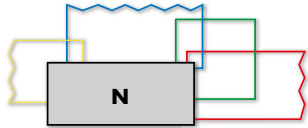





















$\emptyset d_1$ M	P mm	l_1 mm	l_2 mm	d_2 mm	a mm		
12	1.75	110	14	9	7	3	10.3
16	2	110	18	12	9	3	14.1



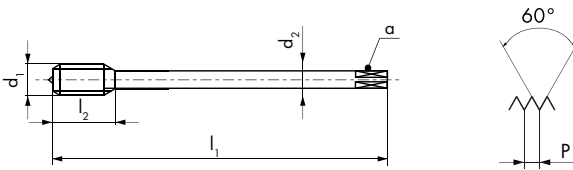







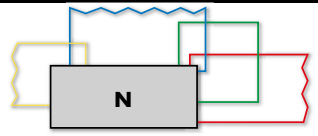

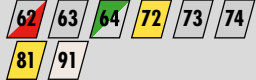



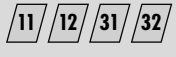





ID	ID
● 102360	● 125044
● 102377	● 145311

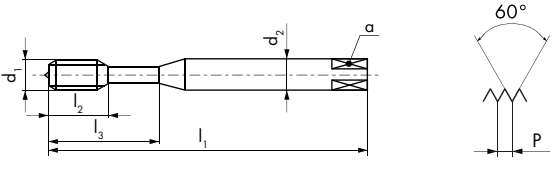

										N360-5	N360V-5	N361-3	N362V-3
<p>N360-5  </p> <p>N360V-5   </p> <p>N361-3   </p> <p>N362V-3    </p>													
													
													
Ø d ₁ M	P mm	l ₁ mm	l ₂ mm	l ₃ mm	d ₂ mm	a mm			ID	ID	ID	ID	
2	0.4	45	7		2.8	2.1	2	1.6	● 158079	● 150058			
3	0.5	56	5.5	18	3.5	2.7	3	2.5	● 104809	● 142646	● 101735		
4	0.7	63	7.5	21	4.5	3.4	3	3.3	● 104810	● 142647	● 101736	● 101741	
5	0.8	70	9	25	6	4.9	3	4.2	● 104811	● 142648	● 101737	● 101742	
6	1	80	11	30	6	4.9	3	5	● 104812	● 142649	● 101738	● 101743	
8	1.25	90	12.5	35	8	6.2	3	6.8	● 104813	● 142650	● 101739	● 101744	
10	1.5	100	14	39	10	8	3	8.5	● 104814	● 124899	● 101734	● 101740	







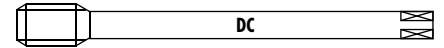

								N460-5	N460V-5	N461-3	N462V-3
<p>N460-5</p>  63 72 73 74 81 91											
<p>N460V-5</p>   11 12 32											
<p>N461-3</p>   61 63 71 72 73 74 81 91											
<p>N462V-3</p>    11 12 32											
											
$\emptyset d_1$ M	P mm	l_1 mm	l_2 mm	d_2 mm	a mm			ID	ID	ID	ID
12	1.75	110	14	9	7	3	10.2	● 104815	● 142651	● 102506	● 102512
14	2	110	14	11	9	3	12				● 102513
16	2	110	18	12	9	3	14				● 102514
18	2.5	125	21	14	11	3	15.5			★ 111614	● 102515
20	2.5	140	24	16	12	4	17.5				● 102516
24	3	160	27	18	14.5	4	21				● 102517
27	3	160	27	20	16	4	24				● 159244
30	3.5	180	30	22	18	4	26.5				● 143090

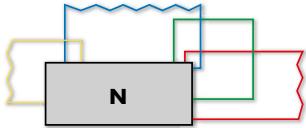
										N520-4	N520V-4	N520TN-4	
N520-4													
N520V-4	 V												
N520TN-4	 TiN												
													
													
Ø d ₁ M	P mm	l ₁ mm	l ₂ mm	l ₃ mm	d ₂ mm	a mm			ID	ID	ID		
2.5	0.45	100	10		2.8	2.1	3	2.05	● 102594	● 142623			
3	0.5	112	12	18	3.5	2.7	3	2.5	● 102595	● 143399	● 162790		
4	0.7	112	14	21	4.5	3.4	3	3.3	● 102596	● 143400	● 146837		
5	0.8	125	15	25	6	4.9	3	4.2	● 102597	● 142654	● 150113		
6	1	125	17	30	6	4.9	3	5	● 102598	● 143137	● 148821		





								N620-4	N620V-4	N620TN-4
N620-4			62 63 64 72 73 74 81 91							
N620V-4		V	11 12 31 32							
N620TN-4		TiN	11 12 13 14 32							
$\emptyset d_1$ M	P mm	l_1 mm	l_2 mm	d_2 mm	a mm			ID	ID	ID
4	0.7	112	14	2.8	2.1	3	3.3	● 102619	● 142582	● 146442
5	0.8	125	15	3.5	2.7	3	4.2	● 102620	● 142657	● 146443
6	1	125	17	4.5	3.4	3	5	● 102621	● 142658	● 144591
8	1.25	140	20	6	4.9	3	6.8	● 102622	● 143401	● 146262
10	1.5	160	22	7	5.5	3	8.5	● 102614	● 142660	● 146849
12	1.75	180	24	9	7	3	10.2	● 102615	● 143127	● 146295
14	2	180	28	11	9	3	12	● 102616	● 151905	
16	2	200	30	12	9	3	14	● 102617	● 143106	● 143574
20	2.5	224	36	16	12	3	17.5	● 102618	● 143596	● 174317







N560-3		63 72 73 74 81 91
N560V-3	 	11 12 32
N560TN-3	 	11 12 13 14 32

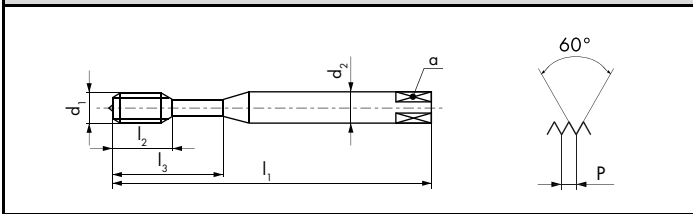

N560-3	N560V-3	N560TN-3	
--------	---------	----------	--



		
---	---	---



		
ISO 2 6H	ISO 2 6H	ISO 2 6H

Ø d ₁ M	P mm	l ₁ mm	l ₂ mm	l ₃ mm	d ₂ mm	a mm			ID	ID	ID
2.5	0.45	100	9		2.8	2.1	2	2.05	● 102600	● 102607	
3	0.5	112	5.5	18	3.5	2.7	3	2.5	● 102601	● 102608	● 142663
4	0.7	112	7.5	21	4.5	3.4	3	3.3	● 102602	● 102609	● 142664
5	0.8	125	9	25	6	4.9	3	4.2	● 102603	● 102610	● 142665
6	1	125	11	30	6	4.9	3	5	● 102604	● 102611	● 142666
8	1.25	140	12.5	35	8	6.2	3	6.8	● 102605	● 102612	● 142667
10	1.5	160	14	39	10	8	3	8.5	● 102599	● 102606	● 142668

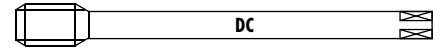

								N660-3	N660V-3	N660TN-3
N660-3										
N660V-3										
N660TN-3										
$\emptyset d_1$ M	P mm	l_1 mm	l_2 mm	d_2 mm	a mm			ID	ID	ID
6	1	125	11	4.5	3.4	3	5	● 162792	● 115657	
8	1.25	140	12.5	6	4.9	3	6.8	● 162793	● 115544	
10	1.5	160	14	7	5.5	3	8.5	● 162794	● 135539	● 173484
12	1.75	180	14	9	7	3	10.2	● 102623	● 102626	● 142669
14	2	180	14	11	9	3	12	● 162253	● 147500	
16	2	200	18	12	9	3	14	● 102624	● 102627	● 142670
20	2.5	224	24	16	12	4	17.5	● 102625	● 102628	● 178003

										W320-4	W420-4	W320DL-4	W420DL-4
W320-4 71 72 81													
W420-4 71 72 81													
W320DL-4 DLC 71 72 73													
W420DL-4 DLC 71 72 73													
$\emptyset d_1$ M	P mm	l_1 mm	l_2 mm	l_3 mm	d_2 mm	a mm				ID	ID	ID	ID
* 2	0.4	45	8		2.8	2.1	2	1.6	● 104612		● 176688		
2.5	0.45	50	10		2.8	2.1	2	2.05	● 104613		● 176689		
3	0.5	56	12	18	3.5	2.7	2	2.5	● 104615		● 176690		
4	0.7	63	14	21	4.5	3.4	2	3.3	● 104617		● 176691		
5	0.8	70	15	25	6	4.9	2	4.2	● 104618		● 176354		
6	1	80	17	30	6	4.9	2	5	● 104619		● 175590		
8	1.25	90	20		6	4.9	2	6.8		● 104636		● 176692	
10	1.5	100	22		7	5.5	2	8.5		● 104632		● 176693	
12	1.75	110	24		9	7	3	10.2		● 104633		● 176694	
16	2	110	30		12	9	3	14		● 104634		● 176695	

*W320-3
 *W320DL-3

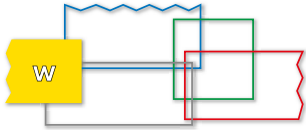
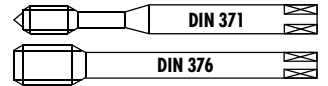

										W360-3	W460-3	W360DL-3	W460DL-3	
<p>W360-3 71 72 81</p> <p>W460-3 71 72 81</p> <p>W360DL-3 71 72 73</p> <p>W460DL-3 71 72 73</p>														
Ø d ₁ M	P mm	l ₁ mm	l ₂ mm	l ₃ mm	d ₂ mm	a mm				ID	ID	ID	ID	
2	0.4	45	7		2.8	2.1	2	1.6	●	104625		●	176719	
2.5	0.45	50	9		2.8	2.1	2	2.05	●	104626		●	176720	
3	0.5	56	5.5	18	3.5	2.7	2	2.5	●	104627		●	176721	
4	0.7	63	7.5	21	4.5	3.4	2	3.3	●	104628		●	176722	
5	0.8	70	9	25	6	4.9	2	4.2	●	104629		●	176723	
6	1	80	11	30	6	4.9	2	5	●	104630		●	176355	
8	1.25	90	12.5	35	8	6.2	2	6.8	●	104631		●	176724	
10	1.5	100	14	39	10	8	2	8.5	●	104624		●	176725	
12	1.75	110	14		9	7	3	10.2			●	104640	●	176726
16	2	110	18		12	9	3	14			●	104641	●	176727

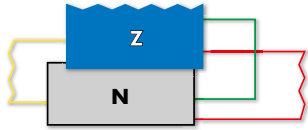

Z320V-4



11 12 13 21 32

Z420V-4



11 12 13 21 32

Z320VS-4



11 12 13 14 21 22
23 32 61 63 94

Z420VS-4



11 12 13 14 21 22
23 32 61 63 94

Z320V-4

Z420V-4

Z320VS-4

Z420VS-4

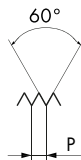
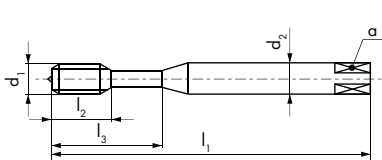

Ø d ₁ M	P mm	l ₁ mm	l ₂ mm	l ₃ mm	d ₂ mm	a mm		
* 1.6	0.35	40	8		2.5	2.1	2	1.25
* 2	0.4	45	8		2.8	2.1	2	1.6
2.5	0.45	50	10		2.8	2.1	3	2.05
2.6	0.45	50	10		2.8	2.1	3	2.15
3	0.5	56	12	18	3.5	2.7	3	2.5
4	0.7	63	14	21	4.5	3.4	3	3.3
5	0.8	70	15	25	6	4.9	3	4.2
6	1	80	17	30	6	4.9	3	5
8	1.25	90	20	35	8	6.2	3	6.8
10	1.5	100	22	39	10	8	3	8.5
12	1.75	110	24		9	7	3	10.2
14	2	110	28		11	9	3	12
16	2	110	30		12	9	3	14
18	2.5	125	33		14	11	4	15.5
20	2.5	140	36		16	12	4	17.5
22	2.5	140	36		18	14.5	4	19.5
24	3	160	39		18	14.5	4	21
30	3.5	180	45		22	18	4	26.5

ID

ID

ID

ID

● 142671

● 111613

● 111455

● 143683

● 142672

● 104669

● 104830

● 104670

● 104831

● 104671

● 104832

● 104672

● 104833

● 104673

● 104834

● 104668

● 104835

● 104723

● 104836

● 142673

● 143684

● 105068

● 111569

● 142674

● 105069

● 111570

● 146003

● 142675

● 150017

● 142676

*Z320V-3



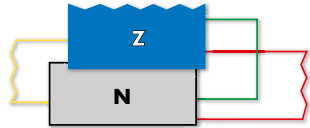
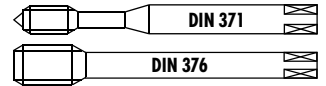

Z360V-3



12 21 32

Z362V-3



12 21 32

Z462V-3



12 21 32

Z360V-3

Z362V-3

Z462V-3

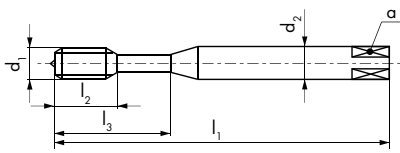

Ø d ₁ M	P mm	l ₁ mm	l ₂ mm	l ₃ mm	d ₂ mm	a mm		
2	0.4	45	7		2.8	2.1	2	1.6
2.5	0.45	50	9		2.8	2.1	2	2.05
2.6	0.45	50	9		2.8	2.1	2	2.15
3	0.5	56	5.5	18	3.5	2.7	3	2.5
3.5	0.6	56	6.5	20	4	3	3	2.9
4	0.7	63	7.5	21	4.5	3.4	3	3.3
5	0.8	70	9	25	6	4.9	3	4.2
6	1	80	11	30	6	4.9	3	5
8	1.25	90	12.5	35	8	6.2	3	6.8
10	1.5	100	14	39	10	8	3	8.5
12	1.75	110	14		9	7	3	10.2
14	2	110	14		11	9	3	12
16	2	110	18		12	9	3	14
18	2.5	125	21		14	11	3	15.5
20	2.5	140	24		16	12	3	17.5
22	2.5	140	24		18	14.5	3	19.5
24	3	160	27		18	14.5	4	21
27	3	160	27		20	16	4	24
30	3.5	180	30		22	18	4	26.5
36	4	200	36		28	22	4	32
42	4.5	200	40		32	24	4	37.5

ID

ID

ID

● 104684

● 104685

● 104686

● 104687

● 104688

● 104689

● 104690

● 104691

● 104692

● 104683

● 104742

● 104743

● 104744

● 104745

● 104746

● 104752

● 104747

● 104748

● 104749

● 104750

● 104751

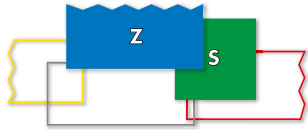

Z362VS-3				12 14 21 22 23 32 61 63
Z370VS-3				14 15 21 22 23 24 51 61
Z373VS-3				94
Z370VS-3				13 14 15 21 22 23 24 51
Z373VS-3				52

Z362VS-3	Z370VS-3	Z370VS-3	Z373VS-3
----------	----------	----------	----------

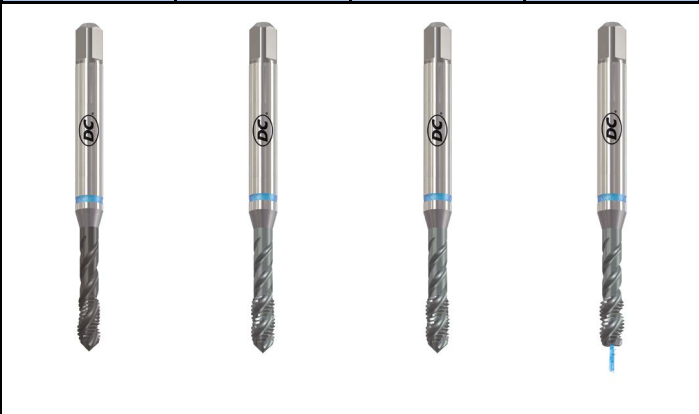

< 2.5 x D	< 3 x D	< 3 x D	< 3 x D
	PM	PM	PM

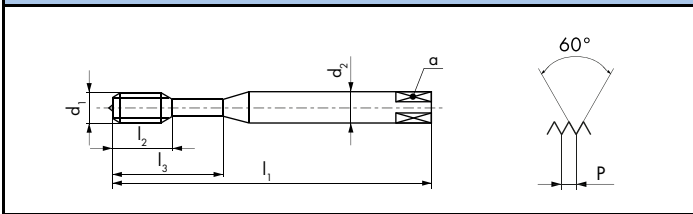

6HX	6HX	4HX	6HX

$\emptyset d_1$ M	P mm	l_1 mm	l_2 mm	l_3 mm	d_2 mm	a mm			ID
* 3	0.5	56	5.5	18	3.5	2.7	3	2.5	● 111504
4	0.7	63	7.5	21	4.5	3.4	3	3.3	● 111505
5	0.8	70	9	25	6	4.9	3	4.2	● 111506
6	1	80	11	30	6	4.9	3	5	● 111507
8	1.25	90	12.5	35	8	6.2	3	6.8	● 111508
10	1.5	100	14	39	10	8	3	8.5	● 111509
*Z360VS-3									

ID	ID	ID
● 162776	● 165324	● 165236
● 162777	● 165325	● 165237
● 162778	● 165326	● 165238
● 162779	● 165327	● 165239
● 162780	● 165328	● 165240
● 162781	● 165438	● 165241

$\emptyset d_1$ M	P mm	l_1 mm	l_2 mm	l_3 mm	d_2 h6 mm	a mm			ID
3	0.5	56	5.5	18	3.5(h9)	2.7	3	2.5	● 162776
4	0.7	63	7.5	21	4.5(h9)	3.4	3	3.3	● 162777
5	0.8	70	9	25	6	4.9	3	4.2	● 162778
6	1	80	11	30	6	4.9	3	5	● 162779
8	1.25	90	12.5	35	8	6.2	3	Δ 6.8	● 162780
10	1.5	100	14	39	10	8	3	8.5	● 162781

ID	ID	ID
● 165324	● 165325	● 165326
● 165327	● 165328	● 165329
● 165328	● 165328	● 165240
● 165438		● 165241

Δ **4HX** = 6.7

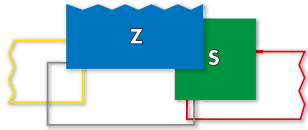

									Z462VS-3	Z470VS-3	Z473VS-3	
<p>Z462VS-3</p> <p>12 14 21 22 23 32 61 63</p>												
<p>Z470VS-3</p> <p>14 15 21 22 23 24 51 61</p>												
<p>Z473VS-3</p> <p>94</p>												
<p>Z470VS-3</p> <p>13 14 15 21 22 23 24 51</p>									<p>< 2.5 x D</p>			
<p>Z473VS-3</p> <p>52</p>									<p>< 3 x D</p>			<p>PM</p>
									<p>2.5 x P</p>			<p>6HX</p>
Ø d ₁ M	P mm	l ₁ mm	l ₂ mm	d ₂ mm	a mm				ID			
12	1.75	110	14	9	7	4	10.2		● 111510			
14	2	110	14	11	9	4	12		★ 148169			
16	2	110	18	12	9	4	14		● 111511			
20	2.5	140	24	16	12	4	17.5		● 111512			
24	3	160	27	18	14.5	4	21		★ 111620			
Ø d ₁ M	P mm	l ₁ mm	l ₂ mm	d ₂ h6 mm	a mm				ID	ID		
12	1.75	110	14	* 10	* 8	4	10.2		● 162782	● 165242		
14	2	110	14	* 12	* 9	4	12		● 162783			
16	2	110	18	12	9	4	14		● 162784	● 165244		
18	2.5	125	21	14	11	4	15.5		● 170643			
20	2.5	140	24	16	12	4	17.5		● 162785	● 165234		
22	2.5	140	24	16	12	4	19.5		● 175190			
24	3	160	27	16	12	4	21		● 162786	● 165235		
* Norme DC / * DC Norm/ * Norma DC												

ZX AMPCO®

ДЛЯ АЛЮМИНИЕВЫХ БРОНЗ

ALU-BRONZE-ALLOYS



ZX - Машинные метчики DC со специально адаптированной геометрией

Для сквозных и глухих отверстий < 1.5 x D

Оптимально
для AMPCO® 21 / 22
Твердость HB > 280 - < 330

Допустимо
для AMPCO® 18
Твердость HB < 420

Допустимо
для AMPCO® 25 / 26
Твердость HB < 420

Рекомендация
для AMPCO® 25 / 26: Диаметр отверстия + 0.2 mm

Дополнительные возможности обработки AMPCO®:

Оптимально
Для сквозных отверстий

DC машинный метчик Тип H320-4 / H420-4
для AMPCO® 18
Твердость HB < 200

Оптимально
Для сквозных и глухих отверстий < 2 x D

для AMPCO® 25 / 26
Твердость HB > 380 - < 420
Смазка: масло/эмульсия

DC твердосплавная резьбофреза тип GF6165VS
Скорость Vc: 30 - 50 м/мин
Подача: 0.01 - 0.05 мм/Зуб

Оптимально
Для сквозных и глухих отверстий < 4 x D

для AMPCO® 25 / 26
Твердость HB > 380 - < 420
Смазка: масло/эмульсия

DC твердосплавная резьбофреза тип GW301.VS / GWi306.VS
Скорость Vc: 30 - 50 м/мин
Подача: 0.01 - 0.08 мм/Зуб

ZX - DC machine taps with specially adapted cutting geometry

For through and blind holes < 1.5 x D

Optimal
for AMPCO® 21 / 22
Hardness Brinell HB > 280 - < 330

Suitable
for AMPCO® 18
Hardness Brinell HB < 420

Suitable
for AMPCO® 25 / 26
Hardness Brinell HB < 420

Recommendation
For AMPCO® 25 / 26: Core hole diameter + 0.2 mm

Alternative AMPCO® threading solutions:

Optimal
For through holes

DC machine taps type H320-4 / H420-4
for AMPCO® 18
Hardness Brinell HB < 200

Optimal
For through and blind holes < 2 x D

for AMPCO® 25 / 26
Hardness Brinell HB > 380 - < 420
Lubricant: cutting oil / emulsion

DC solid carbide thread milling cutter type GF6165VS
Cutting speed Vc: 30 - 50 m/min
Feed rate fz: 0.01 - 0.05 mm/tooth

Optimal
For through and blind holes < 4 x D

for AMPCO® 25 / 26
Hardness Brinell HB > 380 - < 420
Lubricant: cutting oil / emulsion

DC solid carbide thread whirl cutter type GW301.VS / GWi306.VS
Cutting speed Vc: 30 - 50 m/min
Feed rate fz: 0.01 - 0.08 mm/tooth

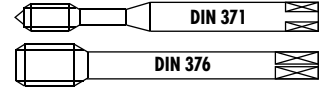

ZX

ZX320-4



AMPCO®
21 22

ZX420-4



AMPCO®
21 22

ZX320-4



AMPCO®
18
25 26

ZX420-4



AMPCO®
18
25 26

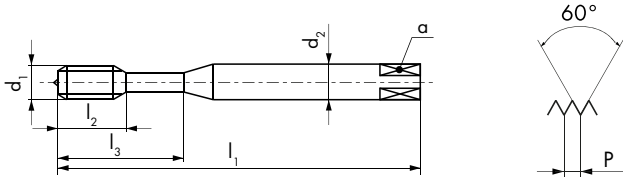

ZX320-4

ZX420-4



6HX

6HX

Ø d ₁ M	P mm	l ₁ mm	l ₂ mm	l ₃ mm	d ₂ mm	a mm		
4	0.7	63	14	21	4.5	3.4	3	* 3.3
5	0.8	70	15	25	6	4.9	3	* 4.2
6	1	80	17	30	6	4.9	3	* 5
8	1.25	90	20	35	8	6.2	3	* 6.8
10	1.5	100	22	39	10	8	3	* 8.5

ID

- 143599
- 145458
- 110232
- 110233
- 124905

Ø d ₁ M	P mm	l ₁ mm	l ₂ mm	d ₂ mm	a mm		
12	1.75	110	24	9	7	3	* 10.2
16	2	110	30	12	9	3	* 14

ID

- 110208
- 110207

*Amcco® 25 / Amcco® 26 + 0.2 mm

ТАБЛИЦА ПРИМЕНЕНИЯ ДЛЯ АЛЮМИНИЕВЫХ БРОНЗ APPLICATION CHART FOR ALU-BRONZE-ALLOYS

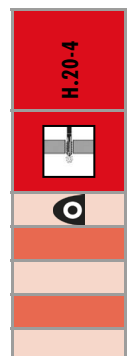
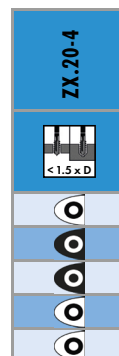

Обозначение материалов Material designation	Твердость Hardness Brinell (HB)	Скорости резания Cutting speed V _c (m/min) Guide Line
AMPCO® 18	< 290	6 - 10
AMPCO® 21	> 280 - < 330	2 - 3
AMPCO® 22	> 280 - < 330	2 - 3
AMPCO® 25	< 420	2 - 3
AMPCO® 26	< 420	2 - 3

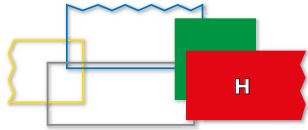



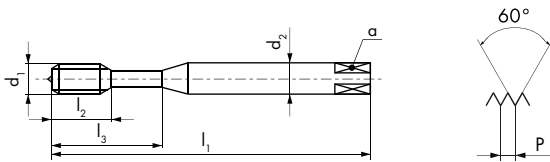

H320-4

15 16 62 64 82
H320TC-4

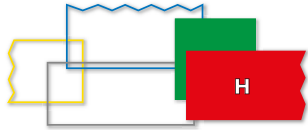
TiCN
15 16 24 31 82 83
92 93
H320-4
H320TC-4





$\emptyset d_1$ M	P mm	l_1 mm	l_2 mm	l_3 mm	d_2 mm	a mm			ID	ID
2	0.4	45	8		2.8	2.1	2	1.6	● 101206	● 151836
2.2	0.45	45	9		2.8	2.1	2	1.75	● 111801	
2.5	0.45	50	10		2.8	2.1	3	2.05	● 101207	● 148603
3	0.5	56	12	18	3.5	2.7	3	2.5	● 101209	● 111836
3.5	0.6	56	13	20	4	3	3	2.9	● 101210	
4	0.7	63	14	21	4.5	3.4	3	3.3	● 101211	● 111502
4.5	0.75	70	15	25	6	4.9	3	3.75	● 101212	
5	0.8	70	15	25	6	4.9	3	4.2	● 101213	● 111458
6	1	80	17	30	6	4.9	3	5	● 101215	● 111456
8	1.25	90	20	35	8	6.2	3	6.8	● 101218	● 111453
10	1.5	100	22	39	10	8	3	8.5	● 101205	● 110911



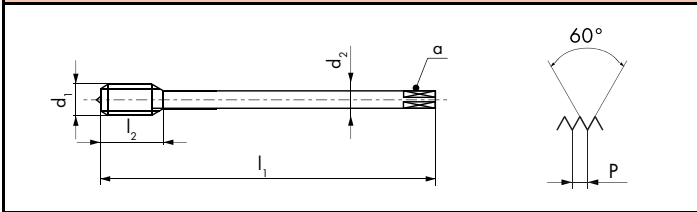
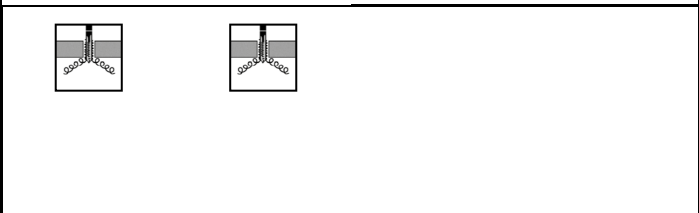

H420-4		15 16 62 64 82
H420TC-4	 	15 16 24 31 82 83 92 93

H420-4	H420TC-4		
---------------	-----------------	--	--



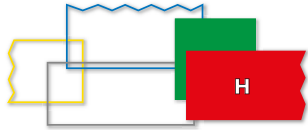

Ø d ₁ M	P mm	l ₁ mm	l ₂ mm	d ₂ mm	a mm			ID	ID
12	1.75	110	24	9	7	4	10.2	● 101275	● 110912
14	2	110	28	11	9	4	12	● 101277	● 145461
16	2	110	30	12	9	4	14	● 101279	● 111612
18	2.5	125	33	14	11	4	15.5	● 101281	
20	2.5	140	36	16	12	4	17.5	● 101284	● 144606
22	2.5	140	36	18	14.5	4	19.5	● 157752	
24	3	160	39	18	14.5	4	21	● 101286	● 143588
27	3	160	42	20	16	4	24	● 101287	
30	3.5	180	45	22	18	4	26.5	● 101288	
36	4	200	51	28	22	4	32	● 101289	

H350-3

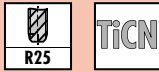
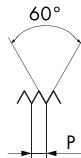
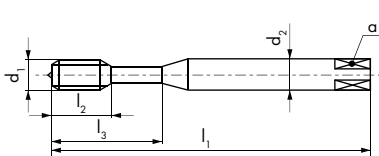
15 16 62 64 82
H350TC-3

15 16 24 31 82 83
92 93
H350-3
H350-3
H350TC-3

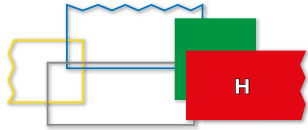
$\emptyset d_1$ M	P mm	l_1 mm	l_2 mm	l_3 mm	d_2 mm	a mm			ID	ID	6H + mm	ID
2	0.4	45	7		2.8	2.1	2	1.6	● 101238			● 146451
2.5	0.45	50	9		2.8	2.1	3	2.05	● 101239			● 144957
3	0.5	56	5.5	18	3.5	2.7	3	2.5	● 101242	● 101241	0.020	● 111835
3.5	0.6	56	6.5	20	4	3	3	2.9	● 101243			
4	0.7	63	7.5	21	4.5	3.4	3	3.3	● 101245	● 101244	0.022	● 111607
4.5	0.75	70	9	25	6	4.9	3	3.75	● 101246			
5	0.8	70	9	25	6	4.9	3	4.2	● 101248	● 101247	0.024	● 111610
6	1	80	11	30	6	4.9	3	5	● 101251	● 101250	0.026	● 111500
8	1.25	90	12.5	35	8	6.2	3	6.8	● 101255	● 101254	0.028	● 110963
10	1.5	100	14	39	10	8	3	8.5	● 101237	● 101236	0.032	● 111454



H450-3



15 16 62 64 82

H450TC-3

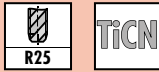



15 16 24 31 82 83
92 93

H450-3

H450-3

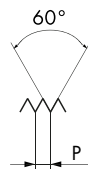
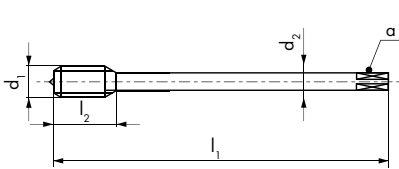
H450TC-3



Ø d ₁ M	P mm	l ₁ mm	l ₂ mm	d ₂ mm	a mm		
12	1.75	110	14	9	7	4	10.2
14	2	110	14	11	9	4	12
16	2	110	18	12	9	4	14
18	2.5	125	21	14	11	4	15.5
20	2.5	140	24	16	12	4	17.5
22	2.5	140	24	18	14.5	4	19.5
24	3	160	27	18	14.5	4	21
27	3	160	27	20	16	4	24
30	3.5	180	30	22	18	4	26.5
36	4	200	36	28	22	4	32
42	4.5	200	40	32	24	4	37.5

ID	ID	6H + mm	ID
● 101305	★ 101304	0.034	● 111501
● 101307			● 146151
● 101309			● 111605
● 101311			
● 101313			● 144986
● 101315			
● 101318			● 144987
● 101320			
● 101323			
● 101324			
● 101325			

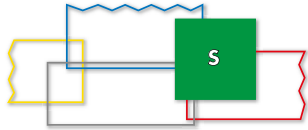
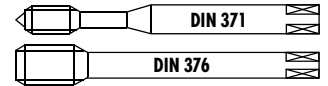

S320VS-4



13 15 16 22 23 24
52

S420VS-4



13 15 16 22 23 24
52

S320VS-4

S320VS-4

S420VS-4

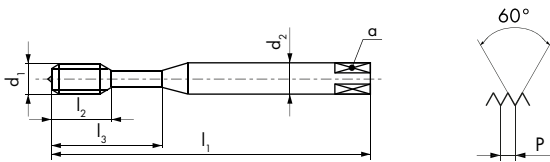

6HX

4HX

6HX

$\emptyset d_1$ M	P mm	l_1 mm	l_2 mm	l_3 mm	d_2 mm	a mm		
3	0.5	56	12	18	3.5	2.7	3	2.5
4	0.7	63	14	21	4.5	3.4	3	3.3
5	0.8	70	15	25	6	4.9	3	4.2
6	1	80	17	30	6	4.9	3	5
8	1.25	90	20	35	8	6.2	3	Δ 6.8
10	1.5	100	22	39	10	8	3	8.5
12	1.75	110	24		9	7	4	10.2
16	2	110	30		12	9	4	14
20	2.5	140	36		16	12	4	17.5

ID

ID

ID

- 111596 ★ 165318
- 111597 ★ 165319
- 111598 ★ 165320
- 111599 ★ 165321
- 111600 ★ 165322
- 111601 ★ 165323

- 111602
- 111603
- 111604

Δ **4HX** = 6.7

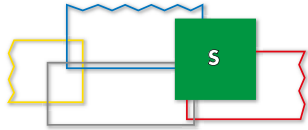
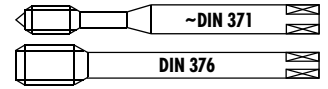

S360VS-3



13 15 16 22 23 24
52

S460VS-3



13 15 16 22 23 24
52

aero

SA390-3



16 53

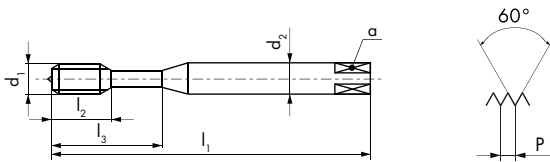

S360VS-3

S460VS-3

SA390-3

SA390-3



6HX

6HX

4HX

6HX

$\emptyset d_1$ M	P mm	l_1 mm	l_2 mm	l_3 mm	d_2 mm	a mm		
3	0.5	56	5.5	18	3.5	2.7	3	2.5
4	0.7	63	7.5	21	4.5	3.4	3	3.3
5	0.8	70	9	25	6	4.9	3	4.2
6	1	80	11	30	6	4.9	3	5
8	1.25	90	12.5	35	8	6.2	3	6.8
10	1.5	100	14	39	10	8	3	8.5
12	1.75	110	14		9	7	4	10.2
14	2	110	14		11	9	4	12
16	2	110	18		12	9	4	14
20	2.5	140	24		16	12	4	17.5
24	3	160	27		18	14.5	4	21

ID

ID

● 111513

● 111514

● 111515

● 111516

● 111517

● 111518

● 111519

* 148171

● 111520

● 111521

● 111606

$\emptyset d_1$ M	P mm	l_1 mm	l_2 mm	d_2 mm	a mm		
4	0.7	63	14	4.5	3.4	3	3.3
5	0.8	70	15	6	4.9	3	4.2
6	1	80	20	6	4.9	3	5
8	1.25	90	25	8	6.2	3	Δ 6.8
10	1.5	100	30	10	8	3	8.5
12	1.75	110	35	12	9	4	10.2
14	2	110	40	16	12	4	12

ID

ID

● 149673

● 149674

● 149693

● 149694

● 149707

● 149708

● 149736

● 149737

* 149754

● 149755

● 149775

● 149775

* 149792

Δ 4HX = 6.7

aero

SA320-4

15 16 52 64
SA350-3

15 16 52 64
TL320VS-4

41 42
TL351VS-3

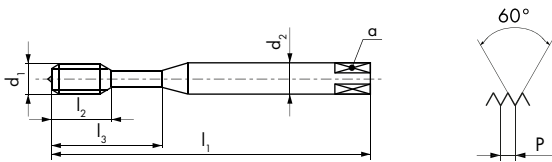
41 42

SA320-4
SA350-3
TL320VS-4
TL351VS-3

4HX
4HX
4HX
4HX

$\emptyset d_1$ M	P mm	l_1 mm	l_2 mm	l_3 mm	d_2 mm	a mm		
3	0.5	56	12		3.5	2.7	3	2.5
4	0.7	63	14		4.5	3.4	3	3.3
5	0.8	70	15		6	4.9	3	4.2
6	1	80	15	23	6	4.9	3	5
8	1.25	90	18	29	8	6.2	3	6.7
10	1.5	100	20	33	10	8	3	8.5

ID
ID
ID
ID

● 147975	● 147987	● 152006	● 152012
● 147976	● 147988	● 152007	● 152013
● 147977	● 147989	● 152008	● 152014
● 147978	● 147990	● 152009	● 152015
● 147979	● 147991	● 152010	● 152016
● 147980	● 147992	● 152011	● 152017

































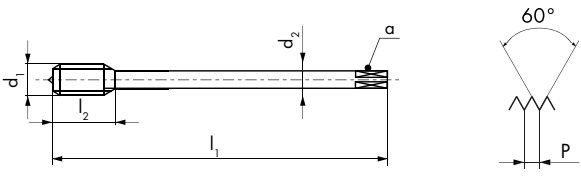

6HX
6HX
6HX
6HX

$\emptyset d_1$ M	P mm	l_1 mm	l_2 mm	l_3 mm	d_2 mm	a mm		
3	0.5	56	12		3.5	2.7	3	2.5
4	0.7	63	14		4.5	3.4	3	3.3
5	0.8	70	15		6	4.9	3	4.2
6	1	80	15	23	6	4.9	3	5
8	1.25	90	18	29	8	6.2	3	6.8
10	1.5	100	20	33	10	8	3	8.5

ID
ID
ID
ID

● 147981	● 147993	● 148001	● 148000
● 147982	● 147994	● 148003	● 148002
● 147983	● 147995	● 148007	● 148006
● 147984	● 147996	● 148011	● 148010
● 147985	● 147997	● 148020	● 148018
● 147986	● 147998	● 148027	● 148025

aero

aero									SA420-4	SA450-3	TL420VS-4	TL451VS-3	
SA420-4													
SA450-3													
TL420VS-4													
TL451VS-3													
													
$\emptyset d_1$ M	P mm	l_1 mm	l_2 mm	d_2 mm	a mm			ID	ID	ID	ID		
12	1.75	110	24	9	7	4	10.2	* 148096	* 152189	* 152192	* 152195		
14	2	110	28	11	9	4	12	* 152187					
16	2	110	30	12	9	4	14	* 152188			* 152197		
									6HX	6HX	6HX	6HX	
$\emptyset d_1$ M	P mm	l_1 mm	l_2 mm	d_2 mm	a mm			ID	ID	ID	ID		
12	1.75	110	24	9	7	4	10.2	* 152198	* 152201	* 152204	● 148028		
14	2	110	28	11	9	4	12	* 152199			● 152207		
16	2	110	30	12	9	4	14		* 152203		● 148029		

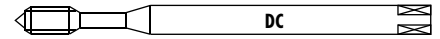
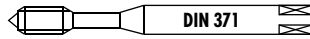

										GG350NV-3	GG350TC-3	GG353TC-3	GG550NV-3
GG350NV-3													
GG350TC-3													
GG353TC-3													
GG550NV-3													
$\emptyset d_1$ M	P mm	l_1 mm	l_2 mm	l_3 mm	d_2 mm	a mm				ID	ID		
3	0.5	56	12	18	3.5	2.7	3	2.5	● 101172	● 101178			
4	0.7	63	14	21	4.5	3.4	3	3.3	● 101173	● 101179			
5	0.8	70	15	25	6	4.9	3	4.2	● 101174	● 101180			
6	1	80	17	30	6	4.9	3	5	● 101175	● 101181			
8	1.25	90	20	35	8	6.2	4	6.8	● 101076	● 101182			
10	1.5	100	22	39	10	8	4	8.5	● 101171	● 101177			
$\emptyset d_1$ M	P mm	l_1 mm	l_2 mm	l_3 mm	d_2 h6 mm	a mm				ID			
5	0.8	70	15	25	6	4.9	3	4.2		● 144947			
6	1	80	17	30	6	4.9	3	5		● 147710			
8	1.25	90	20	35	8	6.2	4	6.8		● 147711			
10	1.5	100	22	39	10	8	4	8.5		● 146708			
$\emptyset d_1$ M	P mm	l_1 mm	l_2 mm	l_3 mm	d_2 mm	a mm				ID			
4	0.7	112	14	21	4.5	3.4	3	3.3		● 101196			
5	0.8	125	15	25	6	4.9	3	4.2		● 101197			
6	1	125	17	30	6	4.9	3	5		● 101198			

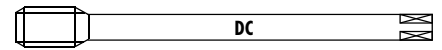

									GG450NV-3	GG450TC-3	GG453TC-3	GG650NV-3
GG450NV-3												
GG450TC-3												
GG453TC-3												
GG650NV-3												
									6HX	6HX	6HX	6HX
Ø d ₁ M	P mm	l ₁ mm	l ₂ mm	d ₂ mm	a mm			ID	ID			
8	1.25	90	20	6	4.9	4	6.8	● 101189	● 101194			
10	1.5	100	22	7	5.5	4	8.5	● 101183	● 101195			
12	1.75	110	24	9	7	4	10.2	● 101184	● 101190			
14	2	110	28	11	9	4	12	● 101185	● 101191			
16	2	110	30	12	9	4	14	● 101186	● 101192			
20	2.5	140	36	16	12	4	17.5	● 101187	● 101193			
24	3	160	39	18	14.5	4	21	● 101188				
Ø d ₁ M	P mm	l ₁ mm	l ₂ mm	d ₂ h6 mm	a mm			ID				
12	1.75	110	24	* 10	* 8	4	10.2	● 146707				
16	2	110	30	12	9	4	14	● 162796				
* Norme DC / * DC Norm/ * Norma DC												
Ø d ₁ M	P mm	l ₁ mm	l ₂ mm	d ₂ mm	a mm			ID				
8	1.25	140	20	6	4.9	4	6.8	● 101203				
10	1.5	160	22	7	5.5	4	8.5	● 101199				
12	1.75	180	24	9	7	4	10.2	● 101200				
16	2	200	30	12	9	4	14	● 101201				
20	2.5	224	36	16	12	4	17.5	● 101202				

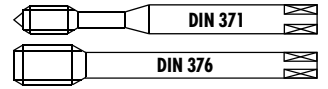

K

K313TC-3

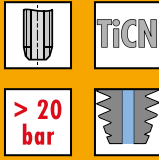

K413TC-3

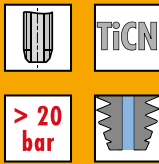

K313TC-3

K413TC-3

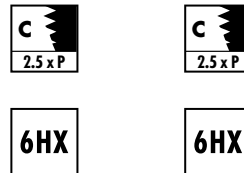
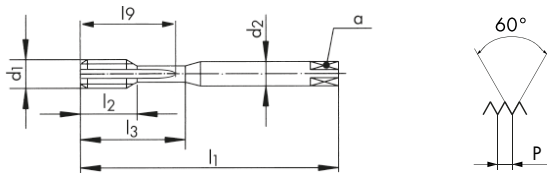
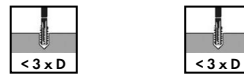

$\emptyset d_1$ M	P mm	l_1 mm	l_2 mm	l_3 mm	l_9 mm	d_2 mm	a mm		
5	0.8	70	15	25	23	6	4.9	3	4.2
6	1	80	17	30	28	6	4.9	3	5
8	1.25	90	20	35	33	8	6.2	3	6.8
10	1.5	100	22	39	37	10	8	3	8.5
12	1.75	110	24		42	9	7	3	10.2
14	2	110	28		49	11	9	3	12
16	2	110	30		56	12	9	4	14
20	2.5	140	36		70	16	12	5	17.5
24	3	160	39		84	18	14.5	5	21

ID

ID

- 175961
- 170766
- 170769
- 170772
- 165838
- 170778
- 170783
- 170786
- 170775

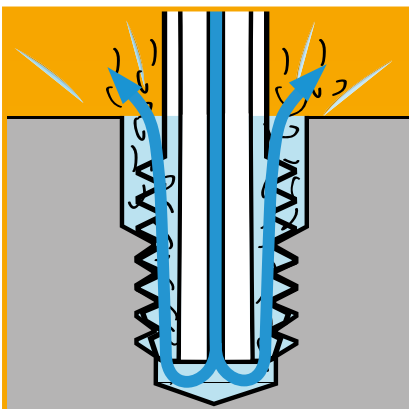



≤ Ø 25.4 > Ø 25.4

PM HSSE

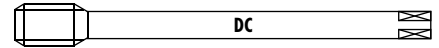

K

K613TC-3

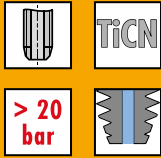

K613VS-3

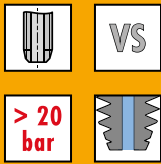

K613TC-3

K613VS-3

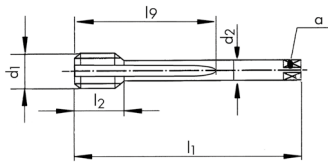

6HX

6HX

Ø d ₁ M	P mm	l ₁ mm	l ₂ mm	l ₉ mm	d ₂ mm	a mm			ID	ID
6	1	110	17	30	4.5	3.4	3	5	● 170646	● 172699
8	1.25	110	20	40	6	4.9	3	6.8	● 170649	● 172700
10	1.5	125	22	50	7	5.5	3	8.5	● 170652	● 172701
12	1.75	140	24	60	9	7	3	10.2	● 167982	● 172702
14	2	140	28	70	11	9	4	12	● 167983	
16	2	160	30	80	12	9	4	14	● 167984	● 170573
20	2.5	180	36	100	16	12	5	17.5	● 167985	● 170576
24	3	200	39	120	18	14.5	5	21	● 167986	● 172704
27	3	225	42	135	20	16	5	24	● 167987	
30	3.5	250	45	150	22	18	5	26.5	● 165542	
33	3.5	280	48	165	25	20	5	29.5	● 167988	
36	4	300	51	180	28	22	6	32	● 167989	
39	4	300	55	195	32	24	6	35	● 167990	
42	4.5	355	55	210	32	24	6	37.5	● 167999	

Vc (m/min) Guide Line

	M5 - M10	M12 - M16	M20 - M30	M33 - M42
	30 - 40	20 - 30	20 - 30	20 - 30
	30 - 40	30 - 40	30 - 40	30 - 40
	20 - 30	15 - 25	15 - 25	15 - 25
	15 - 20	10 - 15	8 - 12	5 - 8
	8 - 12	5 - 8	5 - 8	5 - 8

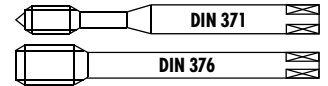

QTAP

Q320VS-4



Q420VS-4



Q323VS-4



Q423VS-4



- 11 12 13 14
- 15 21 22 23
- 24 31 32 51
- 52 61 62 63
- 64 71 72 73
- 74 81 82 83
- 91 92 94

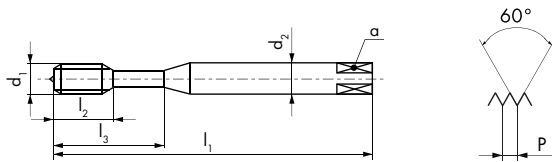

Q320VS-4

Q420VS-4

Q323VS-4

Q423VS-4



NEW



NEW



NEW



NEW



$\emptyset d_1$ M	P mm	l_1 mm	l_2 mm	l_3 mm	d_2 mm	a mm		
3	0.5	56	12	18	3.5	2.7	3	2.5
4	0.7	63	14	21	4.5	3.4	3	3.3
5	0.8	70	15	25	6	4.9	3	4.2
6	1	80	17	30	6	4.9	3	5
8	1.25	90	20	35	8	6.2	3	6.8
10	1.5	100	22	39	10	8	3	8.5
12	1.75	110	24		9	7	3	10.2
14	2	110	28		11	9	3	12
16	2	110	30		12	9	3	14
20	2.5	140	36		16	12	4	17.5
24	3	160	39		18	14.5	4	21

ID	ID	ID	ID
● 195494		● 195505	
● 195495		● 195506	
● 195496		● 195507	
● 195497		● 195508	
● 195498		● 195509	
● 195499		● 195510	
	● 195500		● 195511
	● 195501		● 195512
	● 195502		● 195513
	● 195503		● 195514
	● 195504		● 195515



≤ Ø 16 > Ø 16

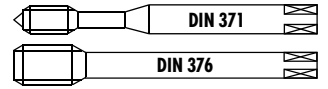

QTAP

Q360VS-3



Q460VS-3



Q363VS-3



Q463VS-3

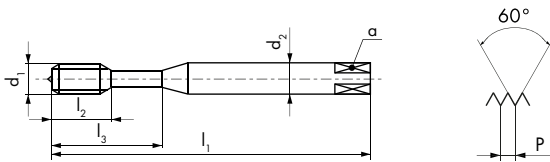

Q360VS-3

Q460VS-3

Q363VS-3

Q463VS-3



NEW



NEW



NEW



NEW



Ø d ₁ M	P mm	l ₁ mm	l ₂ mm	l ₃ mm	d ₂ mm	a mm		
3	0.5	56	5.5	18	3.5	2.7	3	2.5
4	0.7	63	7.5	21	4.5	3.4	3	3.3
5	0.8	70	9	25	6	4.9	3	4.2
6	1	80	11	30	6	4.9	3	5
8	1.25	90	12.5	35	8	6.2	3	6.8
10	1.5	100	14	39	10	8	3	8.5
12	1.75	110	14		9	7	3	10.2
14	2	110	14		11	9	3	12
16	2	110	18		12	9	3	14
20	2.5	140	24		16	12	3	17.5
24	3	160	27		18	14.5	4	21

ID

ID

ID

ID

● 195516

● 195527

● 195517

● 195528

● 195518

● 195529

● 195519

● 195530

● 195520

● 195531

● 195521

● 195532

● 195522 ● 195533

● 195523 ● 195534

● 195524 ● 195535

● 195525 ● 195536

● 195526 ● 195537



Uniquement pour taraudage synchrone
Nur für Synchrobearbeitung
Only for rigid tapping
Solo per mischilatura sincrona
Solo para roscado sincronizado
Только для rigid tapping

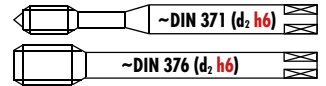

RTS

Rigid Tapping Synchro

RTS320VS-4			<table border="1"> <tr><td>11</td><td>12</td><td>13</td><td>14</td></tr> <tr><td>15</td><td>21</td><td>31</td><td>32</td></tr> <tr><td>51</td><td>61</td><td>63</td><td>64</td></tr> <tr><td>72</td><td>73</td><td>74</td><td>81</td></tr> <tr><td>82</td><td>83</td><td>91</td><td>92</td></tr> <tr><td>94</td><td></td><td></td><td></td></tr> </table>	11	12	13	14	15	21	31	32	51	61	63	64	72	73	74	81	82	83	91	92	94			
11	12	13	14																								
15	21	31	32																								
51	61	63	64																								
72	73	74	81																								
82	83	91	92																								
94																											
RTS420VS-4			<table border="1"> <tr><td>11</td><td>12</td><td>13</td><td>14</td></tr> <tr><td>15</td><td>21</td><td>31</td><td>32</td></tr> <tr><td>51</td><td>61</td><td>63</td><td>64</td></tr> <tr><td>72</td><td>73</td><td>74</td><td>81</td></tr> <tr><td>82</td><td>83</td><td>91</td><td>92</td></tr> <tr><td>94</td><td></td><td></td><td></td></tr> </table>	11	12	13	14	15	21	31	32	51	61	63	64	72	73	74	81	82	83	91	92	94			
11	12	13	14																								
15	21	31	32																								
51	61	63	64																								
72	73	74	81																								
82	83	91	92																								
94																											
RTS323VS-4			<table border="1"> <tr><td>11</td><td>12</td><td>13</td><td>14</td></tr> <tr><td>15</td><td>21</td><td>31</td><td>32</td></tr> <tr><td>51</td><td>61</td><td>63</td><td>64</td></tr> <tr><td>72</td><td>73</td><td>74</td><td>81</td></tr> <tr><td>82</td><td>83</td><td>91</td><td>92</td></tr> <tr><td>94</td><td></td><td></td><td></td></tr> </table>	11	12	13	14	15	21	31	32	51	61	63	64	72	73	74	81	82	83	91	92	94			
11	12	13	14																								
15	21	31	32																								
51	61	63	64																								
72	73	74	81																								
82	83	91	92																								
94																											
RTS423VS-4			<table border="1"> <tr><td>11</td><td>12</td><td>13</td><td>14</td></tr> <tr><td>15</td><td>21</td><td>31</td><td>32</td></tr> <tr><td>51</td><td>61</td><td>63</td><td>64</td></tr> <tr><td>72</td><td>73</td><td>74</td><td>81</td></tr> <tr><td>82</td><td>83</td><td>91</td><td>92</td></tr> <tr><td>94</td><td></td><td></td><td></td></tr> </table>	11	12	13	14	15	21	31	32	51	61	63	64	72	73	74	81	82	83	91	92	94			
11	12	13	14																								
15	21	31	32																								
51	61	63	64																								
72	73	74	81																								
82	83	91	92																								
94																											

RTS320VS-4	RTS420VS-4	RTS323VS-4	RTS423VS-4
------------	------------	------------	------------

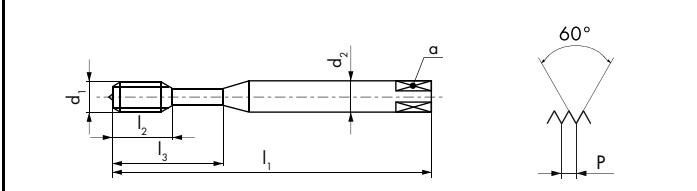
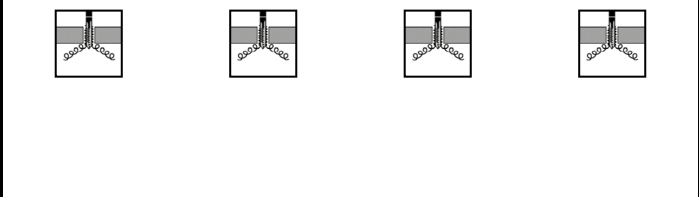

6HX	6HX	6HX	6HX

$\emptyset d_1$ M	P mm	l_1 mm	l_2 mm	l_3 mm	$d_2 h_6$ mm	a mm			ID	ID	ID	ID
* 2	0.4	45	8		2.8(h9)	2.1	2	1.6	● 143532			
2.5	0.45	50	10		2.8(h9)	2.1	3	2.05	● 143534			
3	0.5	56	5.5	18	3.5(h9)	2.7	3	2.5	● 150601			
4	0.7	63	7.5	21	4.5(h9)	3.4	3	3.3	● 150603			
5	0.8	70	9	25	6	4.9	3	4.2	● 150605		● 150606	
6	1	80	11	30	6	4.9	3	5	● 150610		● 150611	
8	1.25	90	12.5	35	8	6.2	3	6.8	● 150620		● 150621	
10	1.5	100	14	39	10	8	3	8.5	● 150635		● 150636	
12	1.75	110	14		* 10	* 8	3	10.2		● 151863		● 151864
14	2	110	14		* 12	* 9	3	12		● 162535		
16	2	110	18		12	9	3	14		● 150670		● 150671
20	2.5	140	24		16	12	4	17.5		● 150679		
24	3	160	27		16	12	4	21		● 162787		

* Norme DC / * DC Norm/ * Norma DC



sur demande
auf Anfrage
on request
su richiesta
sobre pedido
по запросу
≥ 6 mm



Uniquement pour taraudage synchrone
Nur für Synchrobearbeitung
Only for rigid tapping
Solo per mescolatura sincrona
Solo para resacado sincronizado
Только для rigid tapping

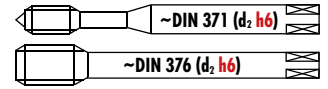

RTS

Rigid Tapping Synchro

RTS362VS-3				<table border="1"> <tr><td>11</td><td>12</td><td>13</td><td>14</td></tr> <tr><td>15</td><td>21</td><td>31</td><td>32</td></tr> <tr><td>51</td><td>61</td><td>63</td><td>64</td></tr> <tr><td>72</td><td>73</td><td>74</td><td>81</td></tr> <tr><td>82</td><td>83</td><td>91</td><td>92</td></tr> <tr><td>94</td><td></td><td></td><td></td></tr> </table>	11	12	13	14	15	21	31	32	51	61	63	64	72	73	74	81	82	83	91	92	94			
11	12	13	14																									
15	21	31	32																									
51	61	63	64																									
72	73	74	81																									
82	83	91	92																									
94																												
RTS462VS-3				<table border="1"> <tr><td>11</td><td>12</td><td>13</td><td>14</td></tr> <tr><td>15</td><td>21</td><td>31</td><td>32</td></tr> <tr><td>51</td><td>61</td><td>63</td><td>64</td></tr> <tr><td>72</td><td>73</td><td>74</td><td>81</td></tr> <tr><td>82</td><td>83</td><td>91</td><td>92</td></tr> <tr><td>94</td><td></td><td></td><td></td></tr> </table>	11	12	13	14	15	21	31	32	51	61	63	64	72	73	74	81	82	83	91	92	94			
11	12	13	14																									
15	21	31	32																									
51	61	63	64																									
72	73	74	81																									
82	83	91	92																									
94																												
RTS365VS-3				<table border="1"> <tr><td>11</td><td>12</td><td>13</td><td>14</td></tr> <tr><td>15</td><td>21</td><td>31</td><td>32</td></tr> <tr><td>51</td><td>61</td><td>63</td><td>64</td></tr> <tr><td>72</td><td>73</td><td>74</td><td>81</td></tr> <tr><td>82</td><td>83</td><td>91</td><td>92</td></tr> <tr><td>94</td><td></td><td></td><td></td></tr> </table>	11	12	13	14	15	21	31	32	51	61	63	64	72	73	74	81	82	83	91	92	94			
11	12	13	14																									
15	21	31	32																									
51	61	63	64																									
72	73	74	81																									
82	83	91	92																									
94																												
RTS465VS-3				<table border="1"> <tr><td>11</td><td>12</td><td>13</td><td>14</td></tr> <tr><td>15</td><td>21</td><td>31</td><td>32</td></tr> <tr><td>51</td><td>61</td><td>63</td><td>64</td></tr> <tr><td>72</td><td>73</td><td>74</td><td>81</td></tr> <tr><td>82</td><td>83</td><td>91</td><td>92</td></tr> <tr><td>94</td><td></td><td></td><td></td></tr> </table>	11	12	13	14	15	21	31	32	51	61	63	64	72	73	74	81	82	83	91	92	94			
11	12	13	14																									
15	21	31	32																									
51	61	63	64																									
72	73	74	81																									
82	83	91	92																									
94																												

RTS362VS-3	RTS462VS-3	RTS365VS-3	RTS465VS-3
------------	------------	------------	------------

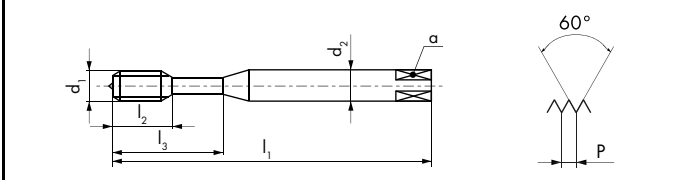
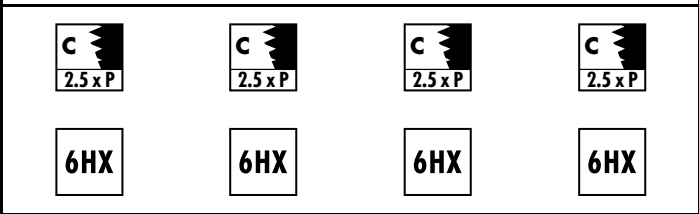
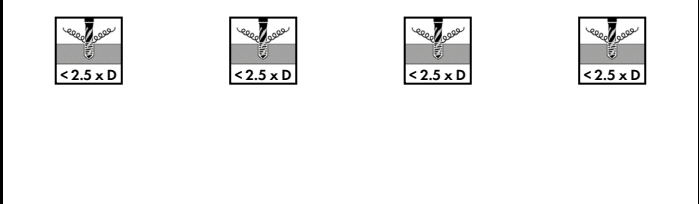

Ø d ₁ M	P mm	l ₁ mm	l ₂ mm	l ₃ mm	d ₂ h6 mm	a mm		
* 2	0.4	45	7		2.8(h9)	2.1	3	1.6
* 2.5	0.45	50	9		2.8(h9)	2.1	3	2.05
3	0.5	56	5.5	18	3.5(h9)	2.7	3	2.5
4	0.7	63	7.5	21	4.5(h9)	3.4	3	3.3
5	0.8	70	9	25	6	4.9	3	4.2
6	1	80	11	30	6	4.9	3	5
8	1.25	90	12.5	35	8	6.2	3	6.8
10	1.5	100	14	39	10	8	3	8.5
12	1.75	110	14		* 10	* 8	3	10.2
14	2	110	14		* 12	* 9	3	12
16	2	110	18		12	9	3	14
20	2.5	140	24		16	12	4	17.5
24	3	160	27		16	12	4	21

ID	ID	ID	ID
● 143536			
● 143538			
● 150602		● 160477	
● 150604		● 160478	
● 150607		● 150608	
● 150612		● 150613	
● 150622		● 150623	
● 150637		● 150638	
	● 151865		● 151866
	● 151870		● 150663
	● 150672		● 150673
	● 150681		● 150682
	● 151873		● 150690

* Norme DC / * DC Norm / * Norma DC

*RTS360VS-3

sur demande
auf Anfrage
on request
su richiesta
sobre pedido
no zampocy

≥ Ø 6 mm



Uniquement pour taraudage synchrone
Nur für Synchronbearbeitung
Only for rigid tapping
Solo per miscelatura sincrona
Solo para roscado sincronizado
Только для rigid tapping

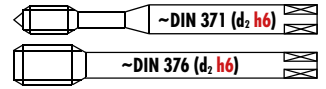

RTS

Rigid Tapping Synchro

RTS362VS-3



RTS462VS-3



RTS362VS-3

RTS462VS-3

RTS362VS-3

RTS462VS-3



NEW

NEW

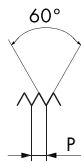
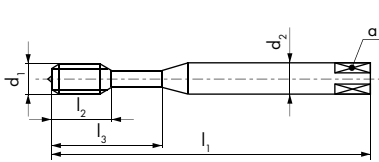

$\emptyset d_1$ M	P mm	l_1 mm	l_2 mm	l_3 mm	$d_2 h6$ mm	a mm		
3	0.5	56	5.5	18	3.5(h9)	2.7	3	2.5
4	0.7	63	7.5	21	4.5(h9)	3.4	3	3.35
5	0.8	70	9	25	6	4.9	3	4.25
6	1	80	11	30	6	4.9	3	5
8	1.25	90	12.5	35	8	6.2	3	6.8
10	1.5	100	14	39	10	8	3	8.5
12	1.75	110	14		* 10	* 8	3	10.3
16	2	110	18		12	9	3	14

* Norme DC / * DC Norm / * Norma DC

ID	6H + mm	ID	6H + mm	ID	6H + mm	ID	6H + mm
● 162797	0.020			● 184689	0.036		
● 162798	0.022			● 184691	0.041		
● 162799	0.024			● 184693	0.044		
● 162800	0.026			● 184695	0.050		
● 162801	0.028			● 184697	0.052		
● 162802	0.032			● 184699	0.060		
		● 163253	0.034			● 184701	0.066
		● 172037	0.038			● 184703	0.072



sur demande
auf Anfrage
on request
su richiesta
sobre pedido
no zapyty

≥ 6 mm



Uniquement pour taraudage synchrone
 Nur für Synchronbearbeitung
 Only for rigid tapping
 Solo per mescolatura sincrona
 Solo para resacado sincronizado
 Только для rigid tapping

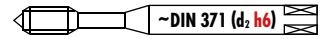

RTS

Rigid Tapping Synchro

RTS362VS-5

R40 VS

RTS365VS-5

R40 VS

11	12	13	14
15	21	31	32
51	61	63	64
72	73	74	81
82	83	91	92
94			

RTS362VS-5 **RTS365VS-5**

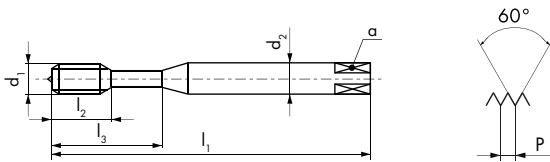

Ø d ₁ M	P mm	l ₁ mm	l ₂ mm	l ₃ mm	d ₂ h6 mm	a mm		
3	0.5	56	5.5	18	3.5(h9)	2.7	3	2.5
4	0.7	63	7.5	21	4.5(h9)	3.4	3	3.3
5	0.8	70	9	25	6	4.9	3	4.2
6	1	80	11	30	6	4.9	3	5
8	1.25	90	12.5	35	8	6.2	3	6.8
10	1.5	100	14	39	10	8	3	8.5

ID	ID
● 157648	
● 157650	
● 157652	● 162791
● 158074	● 151803
● 158076	● 157821
● 153286	● 157823

sur demande
 auf Anfrage
 on request
 su richiesta
 sobre pedido
 по запросу

≥ Ø 6 mm



Uniquement pour taraudage synchro
Nur für Synchrobearbeitung
Only for rigid tapping
Solo per mischilatura sincrona
Solo para roscado sincronizado
Только для rigid tapping

PM

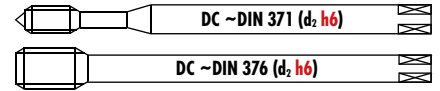

RTS

Rigid Tapping Synchro

RTS523VS-4				<table border="1"> <tr><td>11</td><td>12</td><td>13</td><td>14</td></tr> <tr><td>15</td><td>21</td><td>31</td><td>32</td></tr> <tr><td>51</td><td>61</td><td>63</td><td>64</td></tr> <tr><td>72</td><td>73</td><td>74</td><td>81</td></tr> <tr><td>82</td><td>83</td><td>91</td><td>92</td></tr> <tr><td>94</td><td></td><td></td><td></td></tr> </table>	11	12	13	14	15	21	31	32	51	61	63	64	72	73	74	81	82	83	91	92	94			
11	12	13	14																									
15	21	31	32																									
51	61	63	64																									
72	73	74	81																									
82	83	91	92																									
94																												
RTS623VS-4				<table border="1"> <tr><td>11</td><td>12</td><td>13</td><td>14</td></tr> <tr><td>15</td><td>21</td><td>31</td><td>32</td></tr> <tr><td>51</td><td>61</td><td>63</td><td>64</td></tr> <tr><td>72</td><td>73</td><td>74</td><td>81</td></tr> <tr><td>82</td><td>83</td><td>91</td><td>92</td></tr> <tr><td>94</td><td></td><td></td><td></td></tr> </table>	11	12	13	14	15	21	31	32	51	61	63	64	72	73	74	81	82	83	91	92	94			
11	12	13	14																									
15	21	31	32																									
51	61	63	64																									
72	73	74	81																									
82	83	91	92																									
94																												
RTS565VS-3				<table border="1"> <tr><td>11</td><td>12</td><td>13</td><td>14</td></tr> <tr><td>15</td><td>21</td><td>31</td><td>32</td></tr> <tr><td>51</td><td>61</td><td>63</td><td>64</td></tr> <tr><td>72</td><td>73</td><td>74</td><td>81</td></tr> <tr><td>82</td><td>83</td><td>91</td><td>92</td></tr> <tr><td>94</td><td></td><td></td><td></td></tr> </table>	11	12	13	14	15	21	31	32	51	61	63	64	72	73	74	81	82	83	91	92	94			
11	12	13	14																									
15	21	31	32																									
51	61	63	64																									
72	73	74	81																									
82	83	91	92																									
94																												
RTS665VS-3				<table border="1"> <tr><td>11</td><td>12</td><td>13</td><td>14</td></tr> <tr><td>15</td><td>21</td><td>31</td><td>32</td></tr> <tr><td>51</td><td>61</td><td>63</td><td>64</td></tr> <tr><td>72</td><td>73</td><td>74</td><td>81</td></tr> <tr><td>82</td><td>83</td><td>91</td><td>92</td></tr> <tr><td>94</td><td></td><td></td><td></td></tr> </table>	11	12	13	14	15	21	31	32	51	61	63	64	72	73	74	81	82	83	91	92	94			
11	12	13	14																									
15	21	31	32																									
51	61	63	64																									
72	73	74	81																									
82	83	91	92																									
94																												

RTS523VS-4	RTS623VS-4	RTS565VS-3	RTS665VS-3
------------	------------	------------	------------

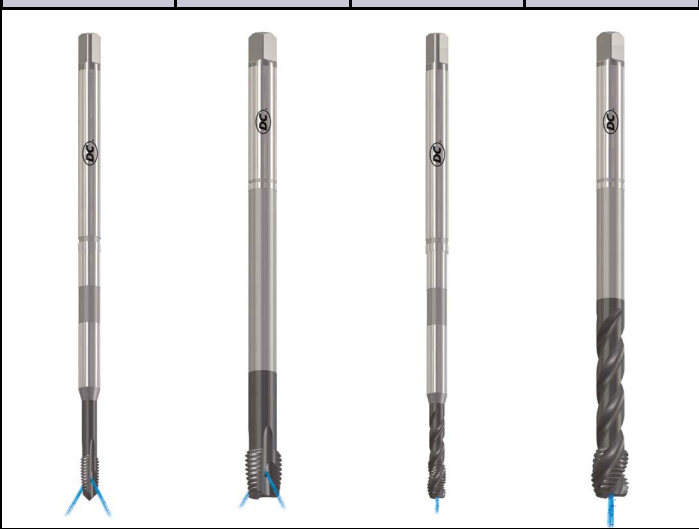

6HX	6HX	6HX	6HX

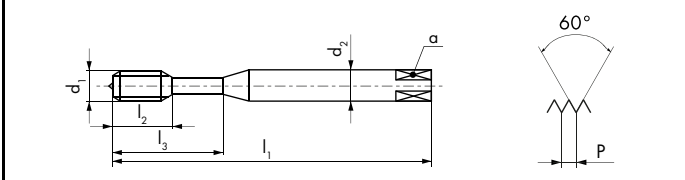

$\emptyset d_1$ M	P mm	l_1 mm	l_2 mm	l_3 mm	$d_2 h_6$ mm	a mm		
5	0.8	125	9	25	6	4.9	3	4.2
6	1	125	11	30	6	4.9	3	5
8	1.25	140	12.5	35	8	6.2	3	6.8
10	1.5	160	14	39	10	8	3	8.5
12	1.75	180	14		* 10	* 8	3	10.2
16	2	200	18		12	9	3	14

* Norme DC / * DC Norm/ * Norma DC

ID	ID
● 161038	
● 161041	
● 161044	
● 161047	
	● 161050
	● 161053

$\emptyset d_1$ M	P mm	l_1 mm	l_2 mm	l_3 mm	$d_2 h_6$ mm	a mm		
6	1	125	11	30	6	4.9	3	5
8	1.25	140	12.5	35	8	6.2	3	6.8
10	1.5	160	14	39	10	8	3	8.5
12	1.75	180	14		* 10	* 8	3	10.2
16	2	200	18		12	9	3	14

* Norme DC / * DC Norm/ * Norma DC

ID	ID	
	● 150614	
	● 150624	
	● 150639	
		● 151867
		● 150674

sur demande
auf Anfrage
on request
su richiesta
sobre pedido
no zapytocy

$\geq \emptyset 6 \text{ mm}$



ОБРАЗОВАНИЕ РАСКАТНИКАМИ

В этом каталоге вы найдете программу раскатников **FS - FPS - FAS** в отдельной главе, начиная **со страницы 244.**

THREAD FORMING

In this catalogue you will find the **FS - FPS - FAS** thread former programme in a separate chapter starting **on page 244.**

										N1110-1	N1110-2	N1110-3	N1110-S
<p>N1110-1</p>													
<p>N1110-2</p>													
<p>N1110-3</p> <p>31 62 73 74 91</p>													
<p>N1110-S</p>													
Ø d ₁ M	P mm	l ₁ mm	l ₂ mm	l ₃ mm	d ₂ mm	a mm			ID	ID	ID	ID	
1	0.25	40	5.5		2.5	2.1	3	0.75	● 102744	● 102844	● 102917	● 111015	
1.2	0.25	40	5.5		2.5	2.1	3	0.95	● 102746	● 102846	● 102919	● 111017	
1.4	0.3	40	7		2.5	2.1	3	1.1	● 102747	● 102847	● 102920	● 111018	
1.6	0.35	40	8		2.5	2.1	3	1.25	● 102749	● 102849	● 102922	● 111020	
1.7	0.35	40	8		2.5	2.1	3	1.35	● 102750	● 102850	● 102923	● 111021	
1.8	0.35	40	8		2.5	2.1	3	1.45	● 102751	● 102851	● 102924	● 111022	
2	0.4	45	8		2.8	2.1	3	1.6	● 102759	● 102854	● 102934	● 111028	
2.2	0.45	45	9.5		2.8	2.1	3	1.75	● 102761	● 102856	● 102937	● 111030	
2.5	0.45	45	9.5		2.8	2.1	3	2.05	● 102763	● 102858	● 102941	● 111032	
2.6	0.45	45	9.5		2.8	2.1	3	2.15	● 102765	● 102860	● 102944	● 111034	
3	0.5	48	11	18	3.15	2.5	3	2.5	● 102766	● 102861	● 102947	● 111036	
3.5	0.6	50	13	20	3.55	2.8	3	2.9	● 102769	● 102864	● 102950	● 111038	
4	0.7	53	13	21	4	3.15	3	3.3	● 102771	● 102866	● 102956	● 111042	
4.5	0.75	53	13	21	4.5	3.55	3	3.75	* 102775	* 102869	* 102959	* 111044	
5	0.8	58	16	25	5	4	3	4.2	● 102776	● 102870	● 102965	● 111047	
6	1	66	19	30	6.3	5	3	5	● 102781	● 102874	● 102973	● 111053	
7	1	66	19	30	7.1	5.6	3	6	* 102786	* 102876	* 102978	* 111055	
8	1.25	72	22	35	8	6.3	3	6.8	● 102788	● 102878	● 102986	● 111059	
9	1.25	72	22	36	9	7.1	3	7.8	* 102792	* 102880	* 102991	* 111061	
10	1.5	80	24	39	10	8	3	8.5	● 102752	● 102852	● 102931	● 111026	

								N1210-1	N1210-2	N1210-3	N1210-S
N1210-1			N1210-3								
N1210-2											
N1210-3											
N1210-S											
$\emptyset d_1$ M	P mm	l_1 mm	l_2 mm	d_2 mm	a mm			ID	ID	ID	ID
11	1.5	85	22	8	6.3	3	9.5	* 103302	* 103427	● 103489	* 111168
12	1.75	89	24	9	7.1	3	10.2	● 103303	● 103428	● 103499	● 111173
14	2	95	24	11.2	9	3	12	● 103310	● 103430	● 103510	● 111179
16	2	102	32	12.5	10	3	14	● 103319	● 103432	● 103522	● 111185
18	2.5	112	30	14	11.2	3	15.5	● 103324	● 103434	● 103534	● 111191
20	2.5	112	37	14	11.2	3	17.5	● 103330	● 103436	● 103543	● 111196
22	2.5	115	32	16	12.5	3	19.5	* 103337	* 103438	* 103550	* 125567
24	3	130	45	18	14	4	21	● 103341	● 103440	● 103557	● 111204
27	3	135	45	20	16	4	24	* 103347	* 103442	* 103568	* 111211
30	3.5	138	48	20	16	4	26.5	● 103353	● 103444	● 103579	● 111216
33	3.5	151	51	22.4	18	4	29.5	* 103357	* 103446	* 103581	* 111218
36	4	162	57	25	20	4	32	* 103359	* 103448	* 103583	* 111220

										NP110-1	NP110-2	NP110-3	NP110-S
NP110-1													
NP110-2													
NP110-3 										NEW	NEW	NEW	NEW
NP110-S													
$\emptyset d_1$ M	P mm	l_1 mm	l_2 mm	l_3 mm	d_2 mm	a mm			ID	ID	ID	ID	
3	0.5	40	11	18	3.5	2.7	3	2.5	● 174678	● 174687	● 174696	● 173676	
4	0.7	45	13	21	4.5	3.4	3	3.3	● 174679	● 174688	● 174697	● 173644	
5	0.8	50	16	24	6	4.9	3	4.2	● 174680	● 174689	● 174698	● 173677	
6	1	56	19	27	6	4.9	3	5	● 174681	● 174690	● 174699	● 173394	

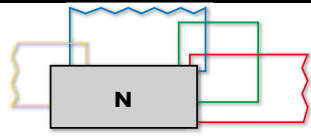

NP210-1	
NP210-2	
NP210-3	 31 62 73 74 91
NP210-S	

NP210-1	NP210-2	NP210-3	NP210-S
---------	---------	---------	---------

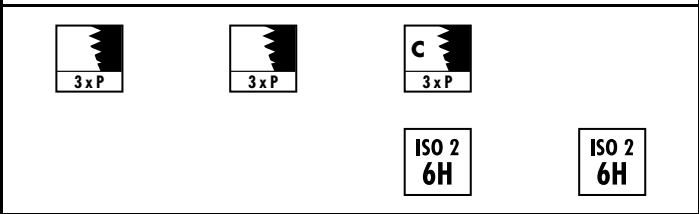
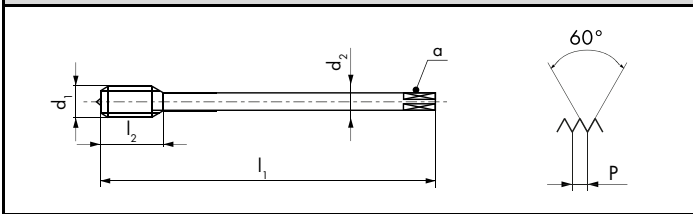
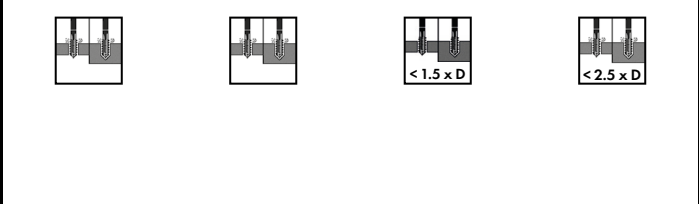

$\varnothing d_1$ M	P mm	l_1 mm	l_2 mm	d_2 mm	a mm			ID	ID	ID	ID
8	1.25	63	22	6	4.9	3		● 174682	● 174691	● 174700	● 173645
10	1.5	70	24	7	5.5	3		● 174683	● 174692	● 174701	● 173646
12	1.75	75	28	9	7	3		● 174684	● 174693	● 174702	● 173647
14	2	80	30	11	9	3		● 174685	● 174694	● 174703	● 173648
16	2	80	32	12	9	3		● 180705	● 180706	● 180707	● 174677

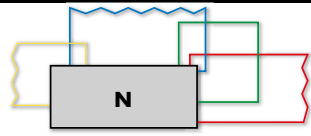
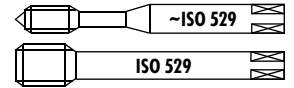

N1120-4	N1220-4	N1160-3	N1260-3
---------	---------	---------	---------

N1120-4		62 63 64 72 73 74 81 91
N1220-4		62 63 64 72 73 74 81 91
N1160-3		63 72 73 74 81 91
N1260-3		63 72 73 74 81 91



--	--	--	--

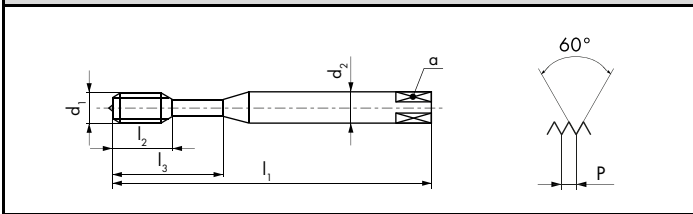

ISO 2 6H	ISO 2 6H	ISO 2 6H	ISO 2 6H

$\emptyset d_1$ M	P mm	l_1 mm	l_2 mm	l_3 mm	d_2 mm	a mm		
3	0.5	48	11	18	3.15	2.5	3	2.5
4	0.7	53	13	21	4	3.15	3	3.3
5	0.8	58	16	25	5	4	3	4.2
6	1	66	19	30	6.3	5	3	5
8	1.25	72	22	35	8	6.3	3	6.8
10	1.5	80	24	39	10	8	3	8.5
12	1.75	89	24		9	7.1	3	10.2
14	2	95	24		11.2	9	3	12
16	2	102	32		12.5	10	3	14

ID	ID
● 103068	
● 103075	
● 103082	
● 103090	
● 103102	
● 103060	
	● 103670
	● 103680
	● 103690

$\emptyset d_1$ M	P mm	l_1 mm	l_2 mm	l_3 mm	d_2 mm	a mm		
3	0.5	48	5.5	18	3.15	2.5	3	2.5
4	0.7	53	7.5	21	4	3.15	3	3.3
5	0.8	58	9	25	5	4	3	4.2
6	1	66	11	30	6.3	5	3	5
8	1.25	72	12.5	35	8	6.3	3	6.8
10	1.5	80	14	39	10	8	3	8.5
12	1.75	89	14		9	7.1	3	10.2
16	2	102	18		12.5	10	3	14











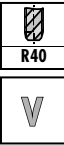
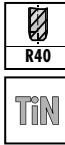
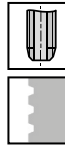
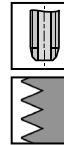
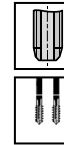



ID	ID
	* 103177
	* 103178
	* 103179
	* 103180
	* 103181
	* 103174
	* 103781
	* 103782

































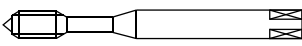
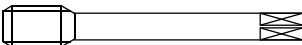



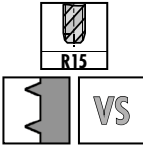
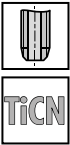

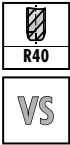











K | DEVELOPING THREADING



	N							
Характеристики Characteristics				 V	 TiN	 R15	 R40	
Типы отверстий Hole type								
		N320-3				N350-3	N360-3	
Длинный по DIN DIN long	DIN 371	124				124	131	
Короткий по ISO ISO short	ISO 529							
Класс точности Tolerance	ISO 2 6H	124				124	131	
Увеличенный Oversize	ISO 3 6G						131	
Повышенный класс точности Fine tolerance	ISO 1 4H							
Левая резьба LH Left-hand thread	ISO 2 6H							
		N410-3	N420-3	N420-4	N420V-4	N420TN-4	N450-3	N460-3
Длинный по DIN DIN long	DIN 374/~DIN 376	125 - 130		125 - 130	125 - 128	125 - 127	124	132 - 133
Короткий по ISO ISO short	ISO 529							
Класс точности Tolerance	ISO 2 6H	125 - 129		125 - 129	125 - 128	125 - 127	124	132 - 133
Увеличенный Oversize	ISO 3 6G							132
Повышенный класс точности Fine tolerance	ISO 1 4H							
Класс точности Tolerance	7H (EN 60423)			128 - 129				
Левая резьба LH Left-hand thread	ISO 2 6H	130		130				

N					Z			
								
								
								
N360V-3	N360TN-3	N1110-1	N1110-3	N1110-S	Z320V-3 Z320V-4	Z320VS-4	Z360V-3	Z370VS-3
131	131				134	134	134	134
		146	146	146				
131	131	146	146	146	134	134	134	134
N460V-3	N460TN-3	N1210-1	N1210-3	N1210-S	Z420V-4	Z420VS-4	Z460V-3	Z470VS-3
132 - 133	132				135	135	135	135
		147 - 148	147 - 148	147 - 148				
132 - 133	132	147 - 148	147 - 148	147 - 148	135	135	135	135

	H		S		SA		
Характеристики Characteristics	 T1CN	 R25 T1CN	 VS	 R35 VS		 R15	 R10
	  NEW	  NEW					
Типы отверстий Hole type							
	H320-4 H320TC-4	H350-3 H350TC-3	S320VS-4	S360VS-3	SA320-4	SA350-3	SA390-3
Длинный по DIN DIN long	DIN 371						
Короткий по ISO ISO short	ISO 529						
Класс точности Tolerance	ISO 2 6H						
Увеличенный Oversize	ISO 3 6G						
Повышенный класс точности Fine tolerance	ISO 1 4H				140	140	
Левая резьба LH Left-hand thread	ISO 2 6H						
	H420-4 H420TC-4	H450-3 H450TC-3	S420VS-4	S460VS-3	SA420-4	SA450-3	
Длинный по DIN DIN long	DIN 374/~DIN 376						
Короткий по ISO ISO short	ISO 529						
Класс точности Tolerance	ISO 2 6H						
Увеличенный Oversize	ISO 3 6G						
Повышенный класс точности Fine tolerance	ISO 1 4H				141	141	
Класс точности Tolerance	7H (EN 60423)						
Левая резьба LH Left-hand thread	ISO 2 6H						

TL		K	QTAP				RTS	
								
								
								
TL320VS-4	TL351VS-3	K313TC-3	Q320VS-4	Q323VS-4	Q360VS-3	Q363VS-3	RTS320VS-4	RTS362VS-3
140	140	142	143	143	144	144	145	145
140	140	142	143	143	144	144	145	145
140	140							
TL420VS-4	TL451VS-3	K413TC-3	Q420VS-4	Q423VS-4	Q460VS-3	Q463VS-3	RTS420VS-4	RTS462VS-3
141	141	142	143	143	144	144	145	145
141	141	142	143	143	144	144	145	145
141	141							

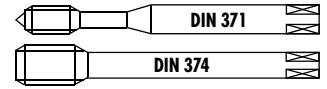
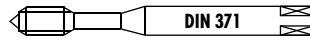

										N320-3		N350-3	N450-3			
N320-3		62 63 64 72 73 74 81 91														
N350-3		62 63 64 72 73 74 81 91														
N450-3		62 63 64 72 73 74 81 91														
Ø d ₁ MF	P mm	l ₁ mm	l ₂ mm	l ₃ mm	d ₂ mm	a mm			ID							
2	0.25	45	8		2.8	2.1	2	1.75	● 142689							
2.5	0.35	50	10		2.8	2.1	3	2.15	● 142691							
2.6	0.35	50	10		2.8	2.1	3	2.25	★ 142692							
3	0.35	56	12	18	3.5	2.7	3	2.65	● 142693							
3.5	0.35	56	13	20	4	3	3	3.15	● 142694							
Ø d ₁ MF	P mm	l ₁ mm	l ₂ mm	l ₃ mm	d ₂ mm	a mm			ID	ID						
4	0.5	63	14	21	4.5	3.4	2	3.5	● 101586							
5	0.5	70	15	25	6	4.9	3	4.5	● 101588							
6	0.75	80	17	30	6	4.9	3	5.25	● 101590							
8	1	90	20		6	4.9	3	7			● 102326					
9	0.75	90	20		7	5.5	3	8.25			● 102328					
10	1	100	22		7	5.5	3	9			● 102313					
18	1.5	110	26		14	11	4	16.5			★ 102322					

MF ISO DIN 13











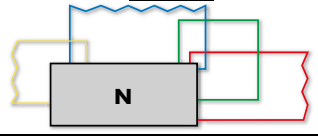



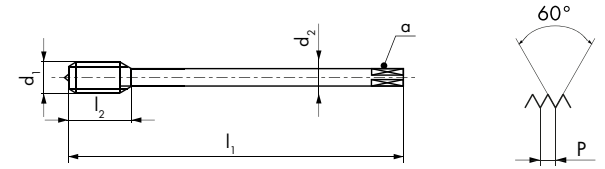

HSSE













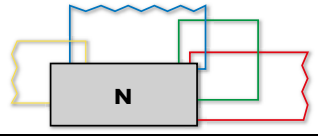













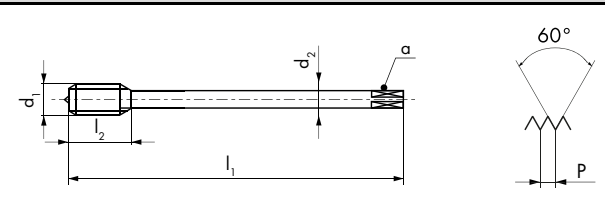

								N410-3	N420-4	N420V-4	N420TN-4
N410-3		31 62 73 74 91									
N420-4		62 63 64 72 73 74 81 91									
N420V-4		V	11 12 31 32								
N420TN-4		TiN	11 12 13 14 32								
$\emptyset d_1$ MF	P mm	l_1 mm	l_2 mm	d_2 mm	a mm			ID	ID	ID	ID
* 4	0.35	63	14	2.8	2.1	3	3.65		● 142695		
4	0.5	63	14	2.8	2.1	3	3.5	● 101923	● 102145	● 142715	
4.5	0.5	70	15	3.5	2.7	3	4		● 102150		
5	0.5	70	15	3.5	2.7	3	4.5	● 101941	● 102167	● 142716	
5	0.75	70	15	3.5	2.7	3	4.25		● 102168		
5.5	0.5	80	17	4	3	3	5		● 142696		
6	0.5	80	17	4.5	3.4	3	5.5	● 101951	● 102178	● 142717	
6	0.75	80	17	4.5	3.4	3	5.25	● 101952	● 102179	● 102281	● 102249
7	0.5	80	17	5.5	4.3	3	6.5		● 102187		
7	0.75	80	17	5.5	4.3	3	6.25	● 101954	● 102188		
8	0.5	90	20	6	4.9	3	7.5	● 101955	● 102190	● 142718	
8	0.75	90	20	6	4.9	3	7.25	● 101956	● 102191	● 102283	
8	1	90	20	6	4.9	3	7	● 101957	● 102192	● 102284	● 102250
9	0.5	90	20	7	5.5	3	8.5		● 142697		
9	0.75	90	20	7	5.5	3	8.25		● 102200		
9	1	90	20	7	5.5	3	8		● 102201	● 143935	
10	0.5	100	22	7	5.5	3	9.5		● 142698		
10	0.75	100	22	7	5.5	3	9.25	● 101863	● 102056		
10	1	100	22	7	5.5	3	9	● 101864	● 102057	● 102262	● 102239
10	1.25	100	22	7	5.5	3	8.8	● 101865	● 102058	● 142719	● 148108











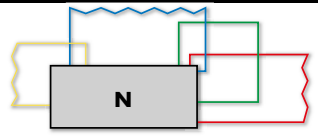











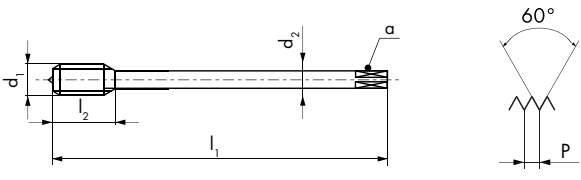

*N420-3











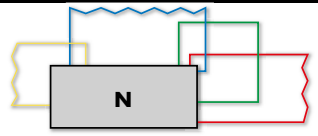

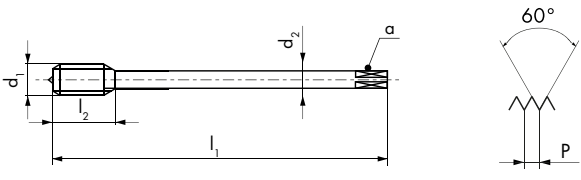

									N410-3	N420-4	N420V-4	N420TN-4
												
N410-3		31 62 73 74 91										
N420-4		62 63 64 72 73 74 81 91										
N420V-4	 V	11 12 31 32										
N420TN-4	 TiN	11 12 13 14 32										
									 	 	 	 
Ø d ₁ MF	P mm	l ₁ mm	l ₂ mm	d ₂ mm	a mm			ID	ID	ID	ID	
11	0.5	100	19	8	6.2	3	10.5		● 142699			
11	0.75	100	19	8	6.2	3	10.25		● 142700			
11	1	100	19	8	6.2	3	10		● 142701			
11	1.25	100	19	8	6.2	3	9.8		● 142702			
12	0.5	100	14	9	7	3	11.5		● 102066			
12	0.75	100	24	9	7	3	11.25		● 142703			
12	1	100	24	9	7	3	11	● 101867	● 102067	● 142345	● 102241	
12	1.25	100	24	9	7	3	10.8	● 101868	● 102068	● 142721		
12	1.5	100	24	9	7	3	10.5	● 101869	● 102069	● 102264	● 102242	
13	1	100	21	11	9	3	12	● 158401	● 142704			
14	0.5	100	14	11	9	3	13.5		● 142705			
14	0.75	100	24	11	9	3	13.25		● 142706			
14	1	100	24	11	9	3	13	● 101871	● 102077			
14	1.25	100	24	11	9	3	12.8	● 101872	● 102078			
14	1.5	100	24	11	9	3	12.5	● 101873	● 102079	● 102266	● 102244	
15	1	100	26	12	9	3	14	● 101875	● 102085			
15	1.5	100	26	12	9	3	13.5	● 101876	● 102086			
16	0.75	100	26	12	9	3	15.25		● 142708			
16	1	100	26	12	9	*3	15	● 101877	● 102087			
16	1.25	100	26	12	9	*3	14.8	● 101878	● 102088			
16	1.5	100	26	12	9	*3	14.5	● 101879	● 102089	● 102268	● 102246	
17	1	100	26	12	9	3	16		● 142709			
17	1.5	100	26	12	9	3	15.5		● 142710			
18	0.75	110	26	14	11	4	17.25		● 142711			
18	1	110	26	14	11	4	17	● 101881	● 102095			
18	1.5	110	26	14	11	4	16.5	● 101882	● 102096	● 102270	● 145350	
18	2	125	33	14	11	3	16		● 142712			

* N410-3 =  4

								N410-3	N420-4	N420V-4	N420TN-4
								 31 62 73 74 91			
 62 63 64 72 73 74 81 91											
 V 11 12 31 32											
 TiN 11 12 13 14 32											
											
											
Ø d ₁ MF	P mm	l ₁ mm	l ₂ mm	d ₂ mm	a mm			ID	ID	ID	ID
20	1	125	28	16	12	4	19		● 102098		
20	1.5	125	28	16	12	4	18.5	● 101884	● 102099	● 102272	● 143932
20	2	140	36	16	12	3	18	● 105130	● 102100		
22	1	125	28	18	14.5	4	21		● 102104		
22	1.5	125	28	18	14.5	4	20.5	● 101886	● 102105	● 102274	
22	2	140	36	18	14.5	3	20	● 101887	● 142714		
24	1	140	30	18	14.5	4	23		● 102107		
24	1.5	140	30	18	14.5	4	22.5	● 101889	● 102108	● 102276	
24	2	140	34	18	14.5	4	22	● 101890	● 102109	● 102277	
25	1	140	30	18	14.5	4	24		● 142722		
25	1.5	140	30	18	14.5	4	23.5	● 101892	● 102112		
25	2	140	34	18	14.5	4	23		● 142723		
26	1	140	30	18	14.5	4	25		● 102113		
26	1.5	140	30	18	14.5	4	24.5	● 101893	● 102114	● 145896	
27	1.5	140	34	20	16	4	25.5		● 102115		
27	2	140	34	20	16	4	25	● 101894	● 102116		
28	1	140	30	20	16	4	27		● 142725		
28	1.5	140	30	20	16	4	26.5	● 101896	● 102118		
28	2	140	30	20	16	4	26	● 122023			

								N410-3	N420-4	N420V-4	N420-3
N410-3		31 62 73 74 91					   				
N420-4		62 63 64 72 73 74 81 91					   				
N420V-4	 	11 12 31 32									
N420-3		62 63 64 72 73 74 81 91									
								   			
								   			
$\emptyset d_1$ MF	P mm	l_1 mm	l_2 mm	d_2 mm	a mm			ID	ID	ID	ID
30	1	150	32	22	18	4	29	● 101898	● 102121		
30	1.5	150	32	22	18	4	28.5	● 101899	● 102122	● 143978	
30	2	150	32	22	18	4	28	● 101900	● 102123	● 143766	
32	1	150	32	22	18	4	31	● 101902			
32	1.5	150	32	22	18	4	30.5	● 101903	● 102126		● 143812
32	2	150	32	22	18	4	30	● 101904	● 102127		
33	1.5	160	32	25	20	4	31.5	● 101905	● 102128		
33	2	160	32	25	20	4	31	● 101906	● 102129		
34	1.5	170	32	28	22	4	32.5	● 101909			
35	1.5	170	32	28	22	4	33.5	● 101910	● 102132		
35	2	170	32	28	22	4	33	● 101911			
36	1.5	170	34	28	22	4	34.5	● 101912	● 102134		
36	2	170	34	28	22	4	34	● 101913	● 102135		
36	3	200	45	28	22	4	33	● 101914	● 102136		
38	1.5	170	34	28	22	4	36.5	● 101917	● 102139		
38	2	170	34	28	22	4	36	● 101918			
39	2	170	34	32	24	4	37	● 101920			
39	3	200	45	32	24	4	36	● 101921			

								N410-3	N420-4	N420-3
								N410-3		31 62 73 74 91
										
								 2.5 x P 	 4 x P 	 2.5 x P 
Ø d ₁ MF	P mm	l ₁ mm	l ₂ mm	d ₂ mm	a mm			ID	ID	ID
40	1	170	34	32	24	5	39	● 101925		
40	1.5	170	34	32	24	5	38.5	● 101926	● 102152	● 143813
40	2	170	34	32	24	5	38	● 101927	● 102153	
40	3	200	45	32	24	4	37	★ 101928		
42	1.5	170	34	32	24	5	40.5	● 101929	● 102155	
42	2	170	34	32	24	5	40	● 101930	● 102156	
42	3	200	45	32	24	4	39	● 101931	● 102157	
45	1.5	180	34	36	29	5	43.5	● 101933	● 102159	
45	2	180	34	36	29	5	43	● 101934		
45	3	200	45	36	29	4	42	● 101935		
48	1.5	190	36	36	29	5	46.5	● 101937	● 102163	
48	2	190	36	36	29	5	46	● 101938	● 102164	
48	3	220	48	36	29	5	45	● 101939	● 102165	
50	1.5	190	36	36	29	5	48.5	● 101943	● 102176	● 143814
50	2	190	36	36	29	5	48	● 101944	★ 102177	
52	2	190	36	40	32	5	50	● 101947		
60	2	220	42	45	35	5	58	● 105132		
63	1.5	220	38	45	35	5	61.5			● 143815

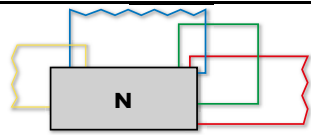

N410-3 LH

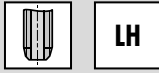

31 62 73 74 91

N420-4 LH





62 63 64 72 73 74
81 91

N410-3 LH

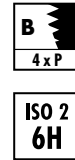
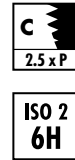
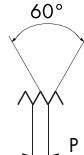
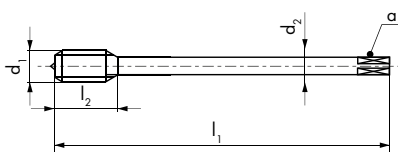
N420-4 LH





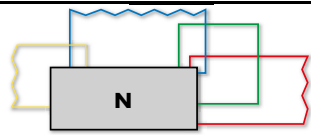

$\emptyset d_1$ MF	P mm	l_1 mm	l_2 mm	d_2 mm	a mm			ID	ID
4	0.5	63	14	2.8	2.1	3	3.5	● 104844	
5	0.5	70	15	3.5	2.7	3	4.5	● 104845	
6	0.5	80	17	4.5	3.4	3	5.5	● 104846	● 104870
6	0.75	80	17	4.5	3.4	3	5.25	● 104847	● 105133
7	0.75	80	17	5.5	4.3	3	6.25	● 104848	
8	0.5	90	20	6	4.9	3	7.5	● 104849	
8	0.75	90	20	6	4.9	3	7.25	● 104850	● 104871
8	1	90	20	6	4.9	3	7	● 104851	● 104872
10	0.75	100	22	7	5.5	3	9.25	● 104852	
10	1	100	22	7	5.5	3	9	● 104853	● 104873
10	1.25	100	22	7	5.5	3	8.8		● 104874
12	1	100	24	9	7	3	11	● 104854	● 104875
12	1.25	100	24	9	7	3	10.8	● 104855	● 104876
12	1.5	100	24	9	7	3	10.5	● 104856	● 104877
14	1	100	24	11	9	3	13	● 104857	● 104878
14	1.25	100	24	11	9	3	12.8	● 104858	
14	1.5	100	24	11	9	3	12.5	● 104859	● 104879
16	1	100	26	12	9	*3	15	● 104860	● 104880
16	1.5	100	26	12	9	*3	14.5	● 104861	● 104881
18	1	110	26	14	11	4	17	● 104862	
18	1.5	110	26	14	11	4	16.5	● 104863	● 104882
20	1	125	28	16	12	4	19	● 104864	
20	1.5	125	28	16	12	4	18.5	● 104865	● 104883
22	1.5	125	28	18	14.5	4	20.5	● 104866	● 104884
24	1.5	140	30	18	14.5	4	22.5	● 104867	● 104885
24	2	140	34	18	14.5	4	22	● 104868	● 104886
28	1.5	140	30	20	16	4	26.5	● 105166	
30	1.5	150	32	22	18	4	28.5	● 105167	● 105165
30	2	150	32	22	18	4	28	● 105168	



















* N410-3 LH =  4









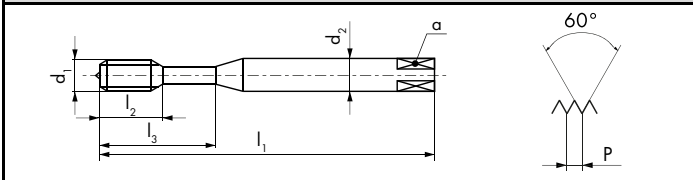

N360-3	N360V-3	N360TN-3	N360-3
--------	---------	----------	--------















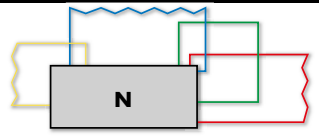















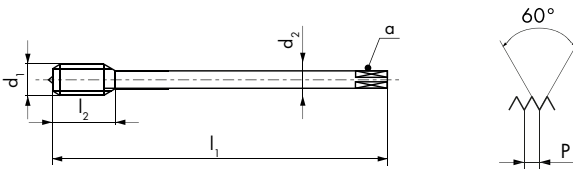

 < 2.5 x D	 < 2.5 x D	 < 2.5 x D	 < 2.5 x D
---	---	---	---

N360-3		     
N360V-3	 	  
N360TN-3	 	    





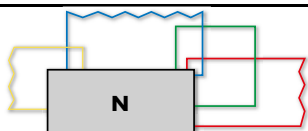

$\emptyset d_1$ MF	P mm	l_1 mm	l_2 mm	l_3 mm	d_2 mm	a mm			ID	ID	ID	ID ^{6H} + mm
4	0.5	63	7.5	21	4.5	3.4	3	3.5	● 101632	● 101712	● 111618	● 101631 0.020
5	0.5	70	9	25	6	4.9	3	4.5	● 101641	● 101714	● 111617	● 101640 0.020
6	0.5	80	11	30	6	4.9	3	5.5	● 101648	● 143990		
6	0.75	80	11	30	6	4.9	3	5.25	● 101650	● 101716	● 101702	● 101649 0.022
8	0.75	90	12.5	35	8	6.2	3	7.25	● 101658	● 101719		● 101657 0.022
8	1	90	12.5	35	8	6.2	3	7	● 101660	● 101720	● 101704	● 101659 0.026
10	0.75	100	14	39	10	8	3	9.25	● 101606	● 144401		
10	1	100	14	39	10	8	3	9	● 101608	● 101706	● 101695	● 101607 0.026
10	1.25	100	14	39	10	8	3	8.8	● 101609	● 105134	● 110965	

								N460-3	N460V-3	N460TN-3	N460-3
N460-3  63 72 73 74 81 91											
N460V-3   11 12 32											
N460TN-3   11 12 13 14 32											
											
											
$\emptyset d_1$ MF	P mm	l_1 mm	l_2 mm	d_2 mm	a mm			ID	ID	ID	ID ^{6H} + mm
12	1	100	14	9	7	3	11	● 102353	● 102462	● 102447	● 102352 0.026
12	1.25	100	14	9	7	3	10.8	● 102354	● 102463	● 144202	
12	1.5	100	14	9	7	3	10.5	● 102356	● 102464	● 102448	● 102355 0.032
13	1	100	14	11	9	3	12	● 102364			
14	1	100	14	11	9	3	13	● 102365	● 102466		
14	1.5	100	14	11	9	3	12.5	● 102367	● 102467	● 102450	● 102366 0.032
15	1	100	14	12	9	3	14	● 102370			
15	1.5	100	18	12	9	3	13.5	● 102371			
16	1	100	14	12	9	4	15	● 102372	● 102469		
16	1.5	100	14	12	9	4	14.5	● 102374	● 102470	● 102452	● 102373 0.032
18	1	110	18	14	11	4	17	● 102380	● 143926		
18	1.5	110	18	14	11	4	16.5	● 102382	● 102472	● 145346	● 102381 0.032
20	1	125	20	16	12	4	19	● 102384	● 146377		
20	1.5	125	20	16	12	4	18.5	● 102386	● 102474	● 148780	
20	2	140	24	16	12	4	18	● 102387	● 143566		
22	1	125	20	18	14.5	4	21	● 102392	● 147702		
22	1.5	125	20	18	14.5	4	20.5	● 102393	● 102476		
24	1.5	140	22	18	14.5	4	22.5	● 102396	● 102478		
24	2	140	22	18	14.5	4	22	● 102397	● 102479		
25	1.5	140	22	18	14.5	4	23.5	● 102399	● 143810		
26	1.5	140	22	18	14.5	4	24.5	● 102400	● 143952		
27	1.5	140	22	20	16	4	25.5	● 102401	● 143965		
27	2	140	22	20	16	4	25	● 102402	● 144201		
28	1.5	140	22	20	16	4	26.5	● 102403	● 144997		







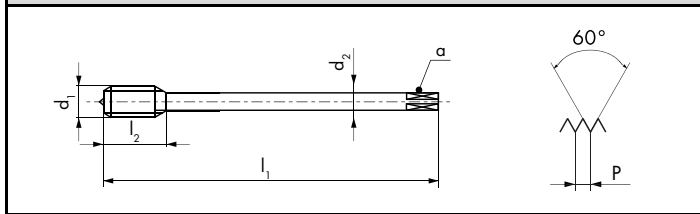

N460-3		63 72 73 74 81 91
N460V-3	 	11 12 32

N460-3	N460V-3
	

	
---	---



$\emptyset d_1$ MF	P mm	l_1 mm	l_2 mm	d_2 mm	a mm			ID	ID
30	1.5	150	24	22	18	4	28.5	● 102404	● 142524
30	2	150	24	22	18	4	28	● 102405	● 142581
32	1.5	150	24	22	18	4	30.5	● 102406	● 143605
33	2	160	26	25	20	4	31	● 102407	● 147604
33	3	180	33	25	20	4	30	● 175437	● 150448
35	1.5	170	24	28	22	5	33.5	● 102408	● 146846
36	1.5	170	24	28	22	5	34.5	● 102409	● 143824
36	2	170	28	28	22	5	34	● 175436	● 164870
36	3	200	36	28	22	4	33	● 115072	● 150453
39	3	200	40	32	24	5	36	● 174995	● 122669
42	3	200	40	32	24	5	39	● 174996	● 150436

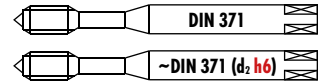

										Z320V-4	Z320VS-4	Z360V-3	Z370VS-3	
Z320V-4		V	11 12 13 21 32											
Z320VS-4		VS	11 12 13 14 21 22 23 32 61 63 94											
Z360V-3		V	12 21 32											
Z370VS-3		VS		14 15 21 22 23 24 51 61 94										
Z370VS-3		VS		13 14 15 21 22 23 24 51 52										PM
										ISO 2 6H	ISO 2 6H	ISO 2 6H	6HX	
Ø d₁ MF	P mm	l₁ mm	l₂ mm	l₃ mm	d₂ mm	a mm				ID	ID			
* 3	0.35	56	12	18	3.5	2.7	3	2.65		● 115468				
6	0.75	80	17	30	6	4.9	3	5.25		● 142726	● 123691			
8	1	90	20	35	8	6.2	3	7		● 142727	● 124289			
10	1	100	22	39	10	8	3	9		● 142728	● 120060			
10	1.25	100	22	39	10	8	3	8.8		● 196023	● 196024			
Ø d₁ MF	P mm	l₁ mm	l₂ mm	l₃ mm	d₂ mm	a mm					ID			
4	0.5	63	7.5	21	4.5	3.4	3	3.5			● 104675			
5	0.5	70	9	25	6	4.9	3	4.5			● 104676			
6	0.75	80	11	30	6	4.9	3	5.25			● 104677			
8	1	90	12.5	35	8	6.2	3	7			● 104678			
10	1	100	14	39	10	8	3	9			● 104674			
Ø d₁ MF	P mm	l₁ mm	l₂ mm	l₃ mm	d₂ h6 mm	a mm					ID			
6	0.75	80	11	30	6	4.9	3	5.25			● 166117			
8	1	90	12.5	35	8	6.2	3	7			● 166118			
10	1	100	14	39	10	8	3	9			● 166119			
10	1.25	100	14	39	10	8	3	8.8			● 196020			
*Z320V-3														



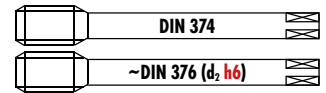

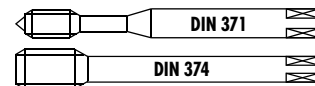

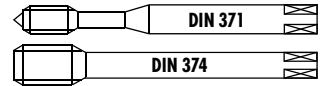

									Z420V-4	Z420VS-4	Z460V-3	Z470VS-3	
Z420V-4		V	11 12 13 21 32										
Z420VS-4		VS	11 12 13 14 21 22 23 32 61 63 94										
Z460V-3		V	12 21 32										
Z470VS-3		VS		14 15 21 22 23 24 51 61 94									
Z470VS-3		VS		13 14 15 21 22 23 24 51 52									PM
									ISO 2 6H	ISO 2 6H	ISO 2 6H	6HX	
Ø d ₁ MF	P mm	l ₁ mm	l ₂ mm	d ₂ mm	a mm				ID	ID			
12	1	100	24	9	7	3	11		● 142729				
12	1.5	100	24	9	7	3	10.5		● 142730	● 120421			
14	1.5	100	24	11	9	3	12.5		● 142731	● 120688			
16	1.5	100	26	12	9	3	14.5		● 142732	● 120878			
18	1.5	110	26	14	11	4	16.5		● 196025	● 196027			
20	1.5	125	28	16	12	4	18.5		● 163931	● 196026			
Ø d ₁ MF	P mm	l ₁ mm	l ₂ mm	d ₂ mm	a mm					ID			
12	1	100	14	9	7	3	11			● 104729			
12	1.5	100	14	9	7	3	10.5			● 104730			
14	1.5	100	14	11	9	3	12.5			● 104731			
16	1.5	100	14	12	9	4	14.5			● 104732			
18	1.5	110	18	14	11	4	16.5			● 104733			
20	1.5	125	20	16	12	4	18.5			● 104734			
22	1.5	125	20	18	14.5	4	20.5			● 104735			
24	1.5	140	22	18	14.5	4	22.5			● 104736			
24	2	140	22	18	14.5	4	22			● 104737			
Ø d ₁ MF	P mm	l ₁ mm	l ₂ mm	d ₂ h ₆ mm	a mm					ID			
12	1.5	110	14	* 10	* 8	4	10.5			● 166120			
14	1.5	110	14	* 12	* 9	4	12.5			● 166121			
16	1.5	110	18	12	9	4	14.5			● 166122			
18	1.5	125	21	14	11	4	16.5			● 196021			
20	1.5	140	24	16	12	4	18.5			● 196022			
									* Norme DC / * DC Norm / * Norma DC				



										H320-4	H420-4	H320TC-4	H420TC-4
H320-4		15 16 62 64 82											
H420-4		15 16 62 64 82										NEW	NEW
H320TC-4		15 16 24 31 82 83 92 93											
H420TC-4		15 16 24 31 82 83 92 93											
$\emptyset d_1$ MF	P mm	l_1 mm	l_2 mm	l_3 mm	d_2 mm	a mm				ID	ID	ID	ID
6	0.75	80	17	30	6	4.9	3			● 101214		● 196035	
8	0.75	90	20	35	8	6.2	3			● 101216			
8	1	90	20	35	8	6.2	3			● 101217		● 196036	
10	1	100	22	39	10	8	3			● 101204		● 172963	
10	1.25	100	22	39	10	8	3			● 175213		● 173079	
12	1.25	100	24		9	7	4				● 101273		
12	1.5	100	24		9	7	4				● 101274		● 196037
14	1.5	100	24		11	9	4			● 101276			● 164053
16	1.5	100	26		12	9	4			● 101278			● 196038
18	1.5	110	26		14	11	4			● 101280			● 196039
20	1.5	125	28		16	12	4			● 101282			● 148362
24	2	140	34		18	14.5	4			● 101285			

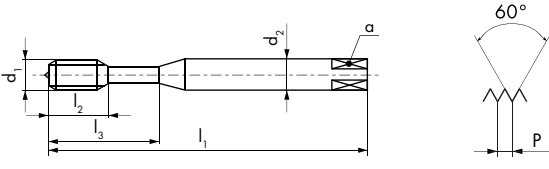
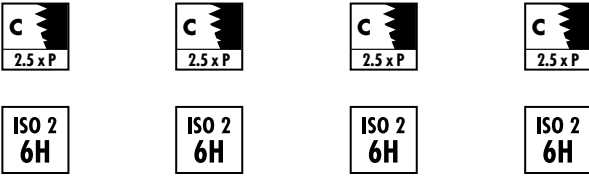

										H350-3	H450-3	H350TC-3	H450TC-3	
														
												NEW	NEW	
														
														
														
Ø d ₁ MF	P mm	l ₁ mm	l ₂ mm	l ₃ mm	d ₂ mm	a mm				ID	ID	ID	ID	
6	0.75	80	11	30	6	4.9	3	5.25		● 101249		● 196033		
8	0.75	90	12.5	35	8	6.2	3	7.25		● 101252				
8	1	90	12.5	35	8	6.2	3	7		● 101253		● 150356		
10	1	100	14	39	10	8	3	9		● 101235		● 148753		
10	1.25	100	14	39	10	8	3	8.8		● 145590		● 196034		
12	1	100	14		9	7	4	11			● 101302			
12	1.5	100	14		9	7	4	10.5			● 101303		● 145561	
14	1.5	100	14		11	9	4	12.5			● 101306		● 184003	
16	1.5	100	14		12	9	4	14.5			● 101308		● 176013	
18	1.5	110	18		14	11	4	16.5			● 101310		● 160146	
20	1.5	125	20		16	12	4	18.5			● 101312		● 160147	
22	1.5	125	20		18	14.5	4	20.5			● 101314			
24	1.5	140	22		18	14.5	4	22.5			● 101316			
24	2	140	22		18	14.5	4	22			● 101317			
27	2	140	22		20	16	4	25			● 101319			
30	1.5	150	24		22	18	4	28.5			● 101321			
30	2	150	24		22	18	4	28			● 101322			

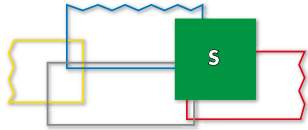

S320VS-4		VS	13 15 16 22 23 24 52
S420VS-4		VS	13 15 16 22 23 24 52
S360VS-3		VS	13 15 16 22 23 24 52
S460VS-3		VS	13 15 16 22 23 24 52

S320VS-4	S420VS-4	S360VS-3	S460VS-3
----------	----------	----------	----------



--	--	--	--

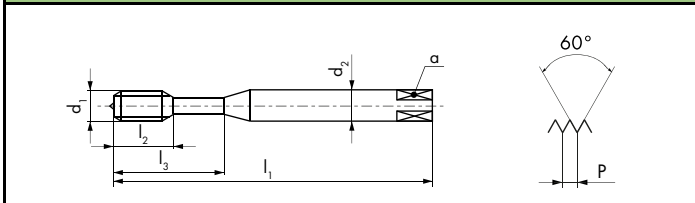

6HX	6HX	6HX	6HX

Ø d ₁ MF	P mm	l ₁ mm	l ₂ mm	l ₃ mm	d ₂ mm	a mm		
6	0.75	80	17	30	6	4.9	3	5.25
8	1	90	20	35	8	6.2	3	7
10	1	100	22	39	10	8	3	9
12	1.5	100	24		9	7	4	10.5
14	1.5	100	24		11	9	4	12.5
16	1.5	100	26		12	9	4	14.5

ID	ID
★ 123690	
● 124288	
● 120059	
	● 120420
	● 120687
	● 120877

Ø d ₁ MF	P mm	l ₁ mm	l ₂ mm	l ₃ mm	d ₂ mm	a mm		
8	1	90	12.5	35	8	6.2	3	7
10	1	100	14	39	10	8	3	9
12	1.5	100	14		9	7	4	10.5
14	1.5	100	14		11	9	4	12.5
16	1.5	100	14		12	9	4	14.5

ID	ID
	● 111528
	● 111529
	● 111540
	● 111541
	● 111542

aero

SA390-3



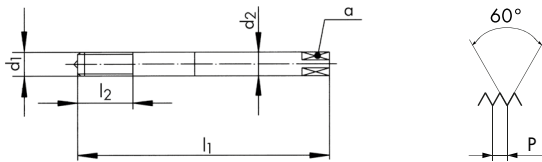

16 53

SA390-3



6HX

$\varnothing d_1$ MF	P mm	l_1 mm	l_2 mm	d_2 mm	a mm			ID
10	1	100	30	10	8	3	9	* 149751
12	1	110	35	12	9	4	11	* 149769
12	1.5	110	35	12	9	4	10.5	* 149773
14	1.5	110	40	16	12	4	12.5	* 149790

aero

SA320-4



15 16 52 64

SA350-3



15 16 52 64

TL320VS-4



41 42

TL351VS-3



41 42

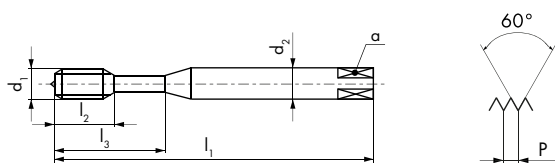

SA320-4

SA350-3

TL320VS-4

TL351VS-3



4HX

4HX

4HX

4HX

Ø d ₁ MF	P mm	l ₁ mm	l ₂ mm	l ₃ mm	d ₂ mm	a mm		
4	0.5	63	14		4.5	3.4	3	3.5
5	0.5	70	15		6	4.9	3	4.5
6	0.5	80	15	23	6	4.9	3	5.5
8	1	90	18	29	8	6.2	3	7
10	1	100	20	33	10	8	3	9







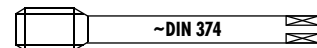

















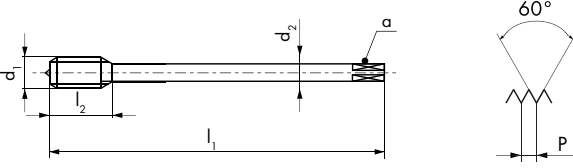





ID	ID	ID	ID
	* 149079		● 152033
	● 149144		● 152049
* 149193		* 152058	● 152059
● 149304	● 149306		● 152080
● 149362	● 149364		● 152093

Ø d ₁ MF	P mm	l ₁ mm	l ₂ mm	l ₃ mm	d ₂ mm	a mm		
4	0.5	63	14		4.5	3.4	3	3.5
5	0.5	70	15		6	4.9	3	4.5
6	0.5	80	15	23	6	4.9	3	5.5
8	1	90	18	29	8	6.2	3	7
10	1	100	20	33	10	8	3	9

ID	ID	ID	ID
● 149081	● 149083		● 152035
● 149146	● 149148		● 152051
	* 149199		● 152061
● 149308	● 149310		● 148019
● 149366	● 149368	* 152094	● 148026



aero

								SA420-4	SA450-3	TL420VS-4	TL451VS-3
SA420-4  15 16 52 64								   			
SA450-3  15 16 52 64											
TL420VS-4   41 42								   			
TL451VS-3   41 42											
								   			
								   			
$\emptyset d_1$	P	l_1	l_2	d_2	a			ID	ID	ID	ID
MF	mm	mm	mm	mm	mm						
12	1	100	19	9	7	4	11	* 152209		* 152218	
12	1.5	100	24	9	7	4	10.5		* 152213		
16	1.5	100	26	12	9	4	14.5		* 152216		* 152226
								   			
$\emptyset d_1$	P	l_1	l_2	d_2	a			ID	ID	ID	ID
MF	mm	mm	mm	mm	mm						
12	1	100	19	9	7	4	11	* 152228		* 152237	
12	1.5	100	24	9	7	4	10.5	* 152227			
14	1.5	100	24	11	9	4	12.5		* 152233	* 152238	
16	1	100	23	12	9	4	15				* 152244
16	1.5	100	26	12	9	4	14.5		* 152235		

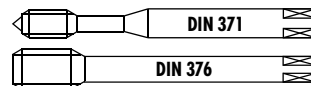
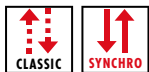

K

K313TC-3

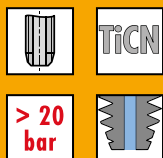

K413TC-3

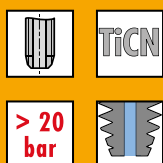

K313TC-3

K413TC-3

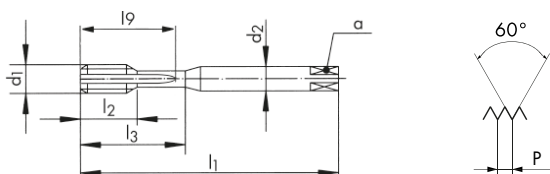

$\emptyset d_1$ MF	P mm	l_1 mm	l_2 mm	l_3 mm	l_9 mm	d_2 mm	a mm			ID	ID
10	1	100	22	39	37	10	8	3	9	● 175729	
10	1.25	100	22	39	37	10	8	3	8.8	● 196067	
12	1	110	24		42	9	7	3	11		● 175731
12	1.25	110	24		42	9	7	3	10.8		● 175733
12	1.5	110	24		42	9	7	3	10.5		● 175735
14	1.5	110	28		49	11	9	3	12.5		● 175737
16	1.5	110	30		56	12	9	3	14.5		● 175739
20	1.5	140	36		70	16	12	5	18.5		● 171205

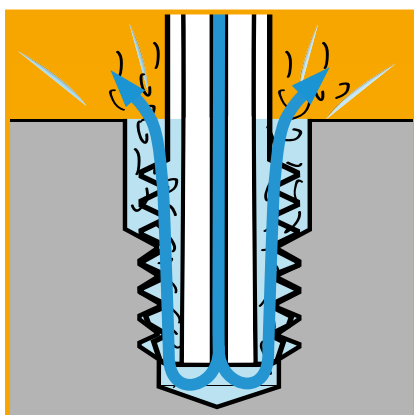



PM

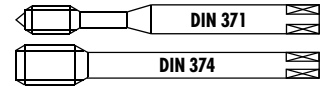

QTAP

Q320VS-4



Q420VS-4



Q323VS-4

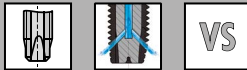

Q423VS-4

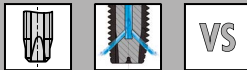

- 11 12 13 14
- 15 21 22 23
- 24 31 32 51
- 52 61 62 63
- 64 71 72 73
- 74 81 82 83
- 91 92 94

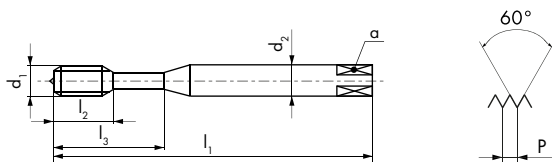

Q320VS-4

Q420VS-4

Q323VS-4

Q423VS-4



NEW



NEW



NEW



NEW



ISO 2
6H



ISO 2
6H



ISO 2
6H



ISO 2
6H

Ø d ₁ MF	P mm	l ₁ mm	l ₂ mm	l ₃ mm	d ₂ mm	a mm		
6	0.75	80	17	30	6	4.9	3	5.25
8	1	90	20	35	8	6.2	3	7
10	1	100	22	39	10	8	3	9
12	1	100	24		9	7	3	11
12	1.5	100	24		9	7	3	10.5
14	1.5	100	24		11	9	3	12.5
16	1.5	100	26		12	9	3	14.5
18	1.5	110	26		14	11	4	16.5
20	1.5	125	28		16	12	4	18.5

ID	ID	ID	ID
● 197661		● 197684	
● 197662		● 197685	
● 197663		● 197686	
	● 197664		● 197687
	● 197665		● 197688
	● 197666		● 197689
	● 197667		● 197690
	● 197668		● 197691
	● 197669		● 197692



≤ Ø 16 > Ø 16

PM HSSE

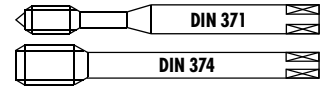

QTAP

Q360VS-3



Q460VS-3



Q363VS-3



Q463VS-3

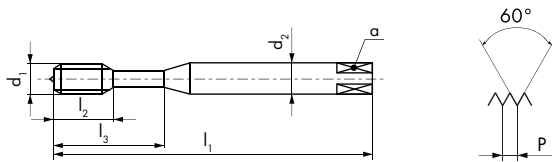
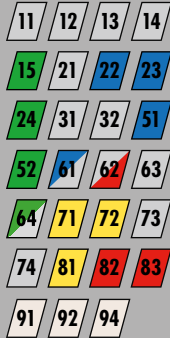

Q360VS-3

Q460VS-3

Q363VS-3

Q463VS-3



NEW



NEW



NEW



NEW



Ø d ₁ MF	P mm	l ₁ mm	l ₂ mm	l ₃ mm	d ₂ mm	a mm			ID	ID	ID	ID
4	0.5	63	7.5	21	4.5	3.4	3	3.5	● 197670		● 197693	
5	0.5	70	9	25	6	4.9	3	4.5	● 197671		● 197694	
6	0.75	80	11	30	6	4.9	3	5.25	● 197672		● 197695	
8	1	90	12.5	35	8	6.2	3	7	● 197673		● 197696	
10	1	100	14	39	10	8	3	9	● 197674		● 197697	
12	1	100	14		9	7	3	11		● 197675		● 197698
12	1.5	100	14		9	7	3	10.5		● 197676		● 197699
14	1.5	100	14		11	9	3	12.5		● 197677		● 197700
16	1.5	100	14		12	9	4	14.5		● 197678		● 197701
18	1.5	110	18		14	11	4	16.5		● 197679		● 197702
20	1.5	125	20		16	12	4	18.5		● 197680		● 197703
22	1.5	125	20		18	14.5	4	20.5		● 197681		● 197704
24	1.5	140	22		18	14.5	4	22.5		● 197682		● 197705
24	2	140	22		18	14.5	4	22		● 197683		● 197706



Uniquement pour taraudage synchro
 Nur für Synchrobearbeitung
 Only for rigid tapping
 Solo per mescolatura sincrona
 Solo para resacado sincronizado
 Только для rigid tapping

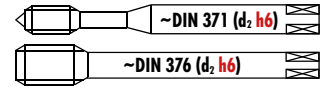

RTS

Rigid Tapping Synchro

RTS320VS-4			<table border="1"> <tr><td>11</td><td>12</td><td>13</td><td>14</td></tr> <tr><td>15</td><td>21</td><td>31</td><td>32</td></tr> <tr><td>51</td><td>61</td><td>63</td><td>64</td></tr> <tr><td>72</td><td>73</td><td>74</td><td>81</td></tr> <tr><td>82</td><td>83</td><td>91</td><td>92</td></tr> <tr><td>94</td><td></td><td></td><td></td></tr> </table>	11	12	13	14	15	21	31	32	51	61	63	64	72	73	74	81	82	83	91	92	94			
11	12	13	14																								
15	21	31	32																								
51	61	63	64																								
72	73	74	81																								
82	83	91	92																								
94																											
RTS420VS-4			<table border="1"> <tr><td>11</td><td>12</td><td>13</td><td>14</td></tr> <tr><td>15</td><td>21</td><td>31</td><td>32</td></tr> <tr><td>51</td><td>61</td><td>63</td><td>64</td></tr> <tr><td>72</td><td>73</td><td>74</td><td>81</td></tr> <tr><td>82</td><td>83</td><td>91</td><td>92</td></tr> <tr><td>94</td><td></td><td></td><td></td></tr> </table>	11	12	13	14	15	21	31	32	51	61	63	64	72	73	74	81	82	83	91	92	94			
11	12	13	14																								
15	21	31	32																								
51	61	63	64																								
72	73	74	81																								
82	83	91	92																								
94																											
RTS362VS-3			<table border="1"> <tr><td>11</td><td>12</td><td>13</td><td>14</td></tr> <tr><td>15</td><td>21</td><td>31</td><td>32</td></tr> <tr><td>51</td><td>61</td><td>63</td><td>64</td></tr> <tr><td>72</td><td>73</td><td>74</td><td>81</td></tr> <tr><td>82</td><td>83</td><td>91</td><td>92</td></tr> <tr><td>94</td><td></td><td></td><td></td></tr> </table>	11	12	13	14	15	21	31	32	51	61	63	64	72	73	74	81	82	83	91	92	94			
11	12	13	14																								
15	21	31	32																								
51	61	63	64																								
72	73	74	81																								
82	83	91	92																								
94																											
RTS462VS-3			<table border="1"> <tr><td>11</td><td>12</td><td>13</td><td>14</td></tr> <tr><td>15</td><td>21</td><td>31</td><td>32</td></tr> <tr><td>51</td><td>61</td><td>63</td><td>64</td></tr> <tr><td>72</td><td>73</td><td>74</td><td>81</td></tr> <tr><td>82</td><td>83</td><td>91</td><td>92</td></tr> <tr><td>94</td><td></td><td></td><td></td></tr> </table>	11	12	13	14	15	21	31	32	51	61	63	64	72	73	74	81	82	83	91	92	94			
11	12	13	14																								
15	21	31	32																								
51	61	63	64																								
72	73	74	81																								
82	83	91	92																								
94																											

RTS320VS-4	RTS420VS-4	RTS362VS-3	RTS462VS-3
------------	------------	------------	------------

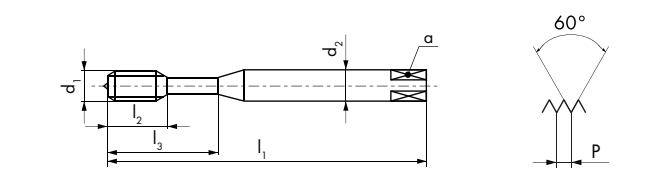
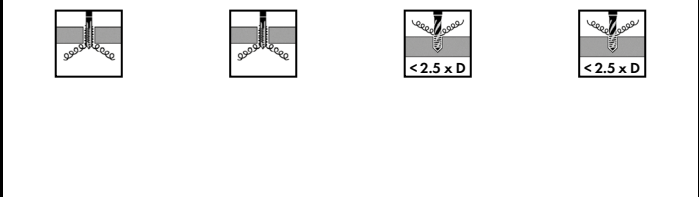

6HX	6HX	6HX	6HX

Ø d ₁ MF	P mm	l ₁ mm	l ₂ mm	l ₃ mm	d ₂ h6 mm	a mm		
8	1	90	12.5	35	8	6.2	3	7
10	1	100	14	39	10	8	3	9
12	1.5	110	14		* 10	* 8	3	10.5
14	1.5	110	14		* 12	* 9	3	12.5
16	1.5	110	18		12	9	3	14.5
* Norme DC / * DC Norm / * Norma DC								

ID	ID
● 150615	
● 150630	
	● 150640
	● 150655
	● 150665









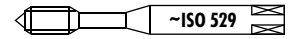

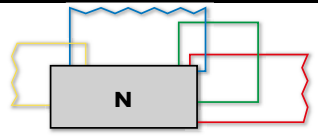
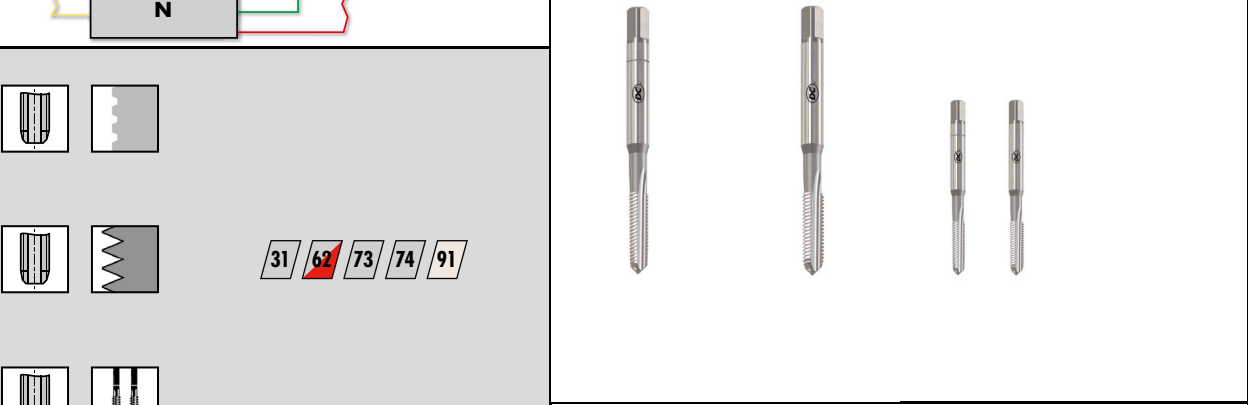





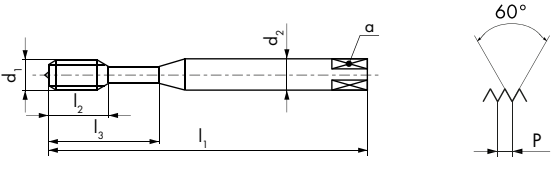

Ø d ₁ MF	P mm	l ₁ mm	l ₂ mm	l ₃ mm	d ₂ h6 mm	a mm		
8	1	90	12.5	35	8	6.2	3	7
10	1	100	14	39	10	8	3	9
12	1.5	110	14		* 10	* 8	3	10.5
14	1.5	110	14		* 12	* 9	3	12.5
16	1.5	110	18		12	9	3	14.5
* Norme DC / * DC Norm / * Norma DC								

ID	ID
● 150617	
● 150632	
	● 151862
	● 151869
	● 151871

sur demande
 auf Anfrage
 on request
 su richiesta
 sobre pedido
 no zapyty

≥ Ø 6 mm



										N1110-1	N1110-3	N1110-S
												
N1110-1												
N1110-3			31	62	73	74	91					
N1110-S												
												
												
Ø d ₁ MF	P mm	l ₁ mm	l ₂ mm	l ₃ mm	d ₂ mm	a mm			ID	ID	ID	
2	0.25	45	8		2.8	2.1	3	1.75		● 102933		
2.2	0.25	45	9.5		2.8	2.1	3	1.95		● 102936		
2.5	0.35	45	9.5		2.8	2.1	3	2.15		● 102940		
3	0.35	48	11	18	3.15	2.5	3	2.65		● 102945		
3.5	0.35	50	13	20	3.55	2.8	3	3.15		● 102949		
4	0.35	53	13	21	4	3.15	3	3.65		● 102952		
4	0.5	53	13	21	4	3.15	3	3.5	● 102773	● 102953	● 111040	
4.5	0.5	53	13	21	4.5	3.55	3	4		● 102958		
5	0.35	58	16	25	5	4	3	4.65		● 102960		
5	0.5	58	16	25	5	4	3	4.5	● 102778	● 102961	● 111045	
5	0.75	58	16	25	5	4	3	4.25		● 102963		
5.5	0.5	62	17	26	5.6	4.5	3	5		● 102967		
6	0.5	66	19	30	6.3	5	3	5.5	● 102783	● 102969	● 111050	
6	0.75	66	19	30	6.3	5	3	5.25	● 102784	● 102971	● 111051	
7	0.5	66	19	30	7.1	5.6	3	6.5		● 102975		
8	0.75	72	22	35	8	6.3	3	7.25	● 102790	● 102982	● 111057	
8	1	72	22	35	8	6.3	3	7	● 102791	● 102984	● 111058	
9	0.5	72	22	36	9	7.1	3	8.5		● 102988		
9	0.75	72	22	36	9	7.1	3	8.25		● 102989		
9	1	72	22	36	9	7.1	3	8		● 102990		
10	0.5	80	24	39	10	8	3	9.5		● 102925		
10	1	80	24	39	10	8	3	9	● 102756	● 102928	● 111024	
10	1.25	80	24	39	10	8	3	8.8	● 102758	● 102930	● 111025	
												
										P 0.25		

								N1210-1	N1210-3	N1210-S	
N1210-1											
N1210-3											
N1210-S											
$\emptyset d_1$ MF	P mm	l_1 mm	l_2 mm	d_2 mm	a mm			ID	ID	ID	
11	0.5	85	22	8	6.3	3	10.5		● 103485		
11	0.75	85	22	8	6.3	3	10.25		● 103486		
11	1	85	22	8	6.3	3	10		● 103487		
11	1.25	85	22	8	6.3	3	9.8		● 103488		
12	0.5	89	24	9	7.1	3	11.5		● 103490		
12	0.75	89	24	9	7.1	3	11.25		● 103491		
12	1	89	24	9	7.1	3	11	● 103305	● 103493	● 111169	
12	1.25	89	24	9	7.1	3	10.8	● 103307	● 103495	● 111171	
12	1.5	89	24	9	7.1	3	10.5	● 103308	● 103497	● 111172	
14	0.5	95	24	11.2	9	3	13.5		● 103502		
14	0.75	95	24	11.2	9	3	13.25		● 103503		
14	1	95	24	11.2	9	3	13	● 103312	● 103504	● 111175	
14	1.25	95	24	11.2	9	3	12.8	● 103314	● 103506	● 111177	
14	1.5	95	24	11.2	9	3	12.5	● 103315	● 103508	● 111178	
15	0.75	90	23	11.2	9	3	14.25		● 103512		
15	1	90	23	11.2	9	3	14		● 103513		
16	0.5	102	32	12.5	10	4	15.5		● 103515		
16	0.75	102	32	12.5	10	4	15.25		● 103516		
16	1	102	32	12.5	10	4	15	● 103321	● 103517	● 111183	
16	1.5	102	32	12.5	10	4	14.5	● 103322	● 103520	● 111184	
17	1	95	23	12.5	10	4	16		● 103525		
18	0.75	112	30	14	11.2	4	17.25		● 103527		
18	1	112	30	14	11.2	4	17	● 103326	● 103528	● 111187	
18	1.5	112	30	14	11.2	4	16.5	● 103327	● 103531	● 111188	
18	2	112	30	14	11.2	3	16		● 103533		
19	1	112	33	14	11.2	4	18		● 103536		



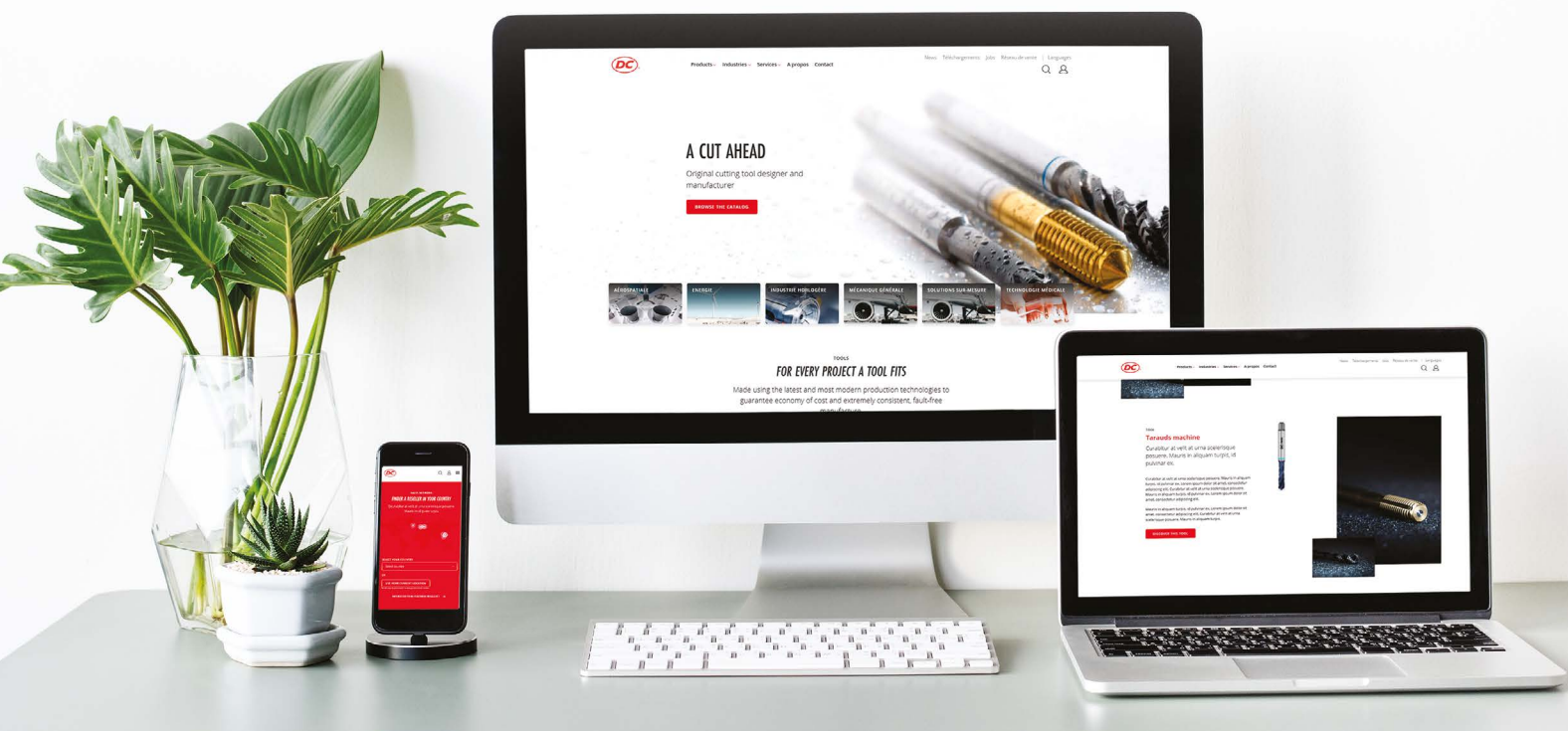









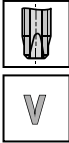







									N1210-1	N1210-3	N1210-S
N1210-1											
N1210-3 31 62 73 74 91											
N1210-S											
Ø d ₁ MF	P mm	l ₁ mm	l ₂ mm	d ₂ mm	a mm				ID	ID	ID
20	1	112	37	14	11.2	4	19		● 103332	● 103537	● 111198
20	1.25	112	37	14	11.2	4	18.8			● 103539	
20	1.5	112	37	14	11.2	4	18.5		● 103334	● 103540	● 111195
22	1	115	32	16	12.5	4	21			● 103545	
22	1.5	115	32	16	12.5	4	20.5		● 103340	● 103546	● 121669
22	2	115	32	16	12.5	3	20			● 103548	
24	1	120	30	18	14	4	23			● 103552	
24	1.5	120	30	18	14	4	22.5		● 103343	● 103553	● 111202
24	2	130	45	18	14	4	22		● 103344	● 103555	● 111203
25	1	120	30	18	14	4	24			● 103559	
25	1.5	120	30	18	14	4	23.5			● 103560	
25	2	120	30	18	14	4	23			● 103561	
26	1	120	30	18	14	4	25			● 103562	
26	1.5	120	30	18	14	4	24.5		● 103346	● 103563	● 111207
26	2	120	30	18	14	4	24			● 103564	
27	1	127	30	20	16	4	26			● 103565	
27	1.5	127	30	20	16	4	25.5			● 103566	
27	2	135	45	20	16	4	25		★ 103351	★ 103567	★ 111210
28	1	127	30	20	16	4	27			● 103570	
28	1.5	127	30	20	16	4	26.5			● 103571	
30	1.5	127	32	20	16	4	28.5		● 103355	● 103575	● 111214
30	2	127	32	20	16	4	28		● 103356	● 103577	● 111215









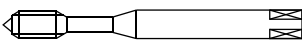
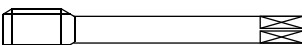

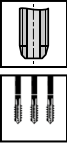

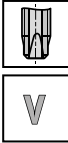

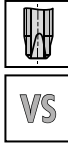

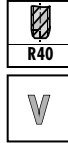

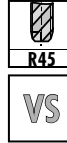





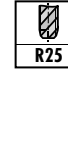













НОВЫЙ САЙТ
В РАЗРАБОТКЕ - СТАРТ ЛЕТОМ 2021 ГОДА.



















NEW WEBSITE
UNDER CONSTRUCTION — RELEASED IN SUMMER 2021.



		N						
Характеристики Characteristics								
								
Типы отверстий Hole type								
		N310-3	N320-3 N320-4	N320V-4	N320TN-4	N360-3	N360V-3	N360TN-3
Длинный по DIN DIN long	DIN 371	154	154	154	154	156	156	156
Короткий по ISO ISO short	ISO 529							
Класс точности Tolerance	UNC 2B	154	154	154	154	156	156	156
Класс точности Tolerance	UNC 3B							
Класс точности Tolerance	UNC(J) 3B		154			156		
		N410-3	N420-4	N420V-4	N420TN-4	N460-3	N460V-3	N460TN-3
Длинный по DIN DIN long	DIN 376	155	155	155	155	157	157	157
Короткий по ISO ISO short	ISO 529							
Класс точности Tolerance	UNC 2B	155	155	155	155	157	157	157
Класс точности Tolerance	UNC 3B							
Класс точности Tolerance	UNC(J) 3B							

N	Z				H			
 	 	 	 	 	 	 	 	 
	V	VS	R40 V	R45 VS		TiCN	R25	R25 TiCN
						 NEW		 NEW
								
N1110 -1 -2 -3 -S	Z320V-3 Z320V-4	Z320VS-4	Z360V-3 Z362V-3	Z370VS-3	H320-4	H320TC-4	H350-3	H350TC-3
170	158	158	159	160	161	161	162	162
170	158	158	159	160	161	161	162	162
				160				
N1210 -1 -2 -3 -S	Z420V-4	Z420VS-4	Z462V-3	Z470VS-3	H420-4	H420TC-4	H450-3	H450TC-3
171	158	158	159	160	161	161	162	162
171	158	158	159	160	161	161	162	162

	S		SA			TL	
Характеристики Characteristics							
Типы отверстий Hole type							
	S320VS-4	S360VS-3	SA320-4	SA350-3	SA390-3	TL320VS-4	TL351VS-3
Длинный по DIN DIN long	DIN 371						
Короткий по ISO ISO short	ISO 529						
Класс точности Tolerance	UNC 2B						
Класс точности Tolerance	UNC 3B						
Класс точности Tolerance	UNC(J) 3B						
	S420VS-4	S460VS-3	SA420-4	SA450-3			
Длинный по DIN DIN long	DIN 376						
Короткий по ISO ISO short	ISO 529						
Класс точности Tolerance	UNC 2B						
Класс точности Tolerance	UNC 3B						
Класс точности Tolerance	UNC(J) 3B						









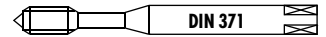

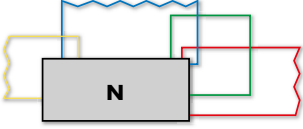





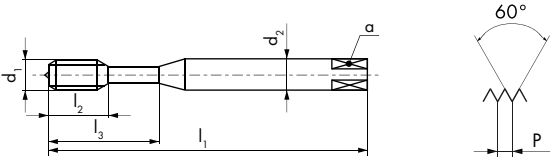

Q				RTS	
					
VS	VS	VS	VS	VS	VS
					
NEW	NEW	NEW	NEW		
					
Q320VS-4	Q323VS-4	Q360VS-3	Q363VS-3	RTS320VS-4	RTS362VS-3
167	167	168	168	169	169
167	167	168	168	169	169
Q420VS-4	Q423VS-4	Q460VS-3	Q463VS-3	RTS420VS-4	RTS462VS-3
167	167	168	168	169	169
167	167	168	168	169	169

UNC ASME B1.1

≤ Ø 2.8 > Ø 2.8

PM HSSE



										N310-3	N320-4	N320V-4	N320TN-4
										N310-3		31 62 73 74 91	
N320-4		62 63 64 72 73 74 81 91											
N320V-4	 V	11 12 31 32											
N320TN-4	 TiN	11 12 13 14 32											NEW
													
										2B	2B	2B	2B
Ø" d ₁ UNC	P TPI	d ₁ mm	l ₁ mm	l ₂ mm	l ₃ mm	d ₂ mm	a mm			ID	ID	ID	ID
* 2	56	2.18	45	9		2.8	2.1	2	1.75		● 101469	● 143690	
* 3	48	2.51	50	10		2.8	2.1	2	2		● 101470		
4	40	2.84	56	12	18	3.5	2.7	3	2.25	● 101450	● 101511	● 142738	
5	40	3.17	56	12	18	3.5	2.7	3	2.55		● 101512		
6	32	3.5	56	13	20	4	3	3	2.75	● 101451	● 101514	● 144402	● 196003
8	32	4.16	63	14	21	4.5	3.4	3	3.4	● 101452	● 101515	● 142739	● 196004
10	24	4.82	70	15	25	6	4.9	3	3.8	● 101449	● 101508	● 142740	● 196005
12	24	5.48	80	17	30	6	4.9	3	4.4		● 101509		
1/4	20	6.35	80	17	30	7	5.5	3	5.1	● 101448	● 101507	● 142741	● 196006
											3B UNC(J)		
Ø d ₁ UNC	P TPI	d ₁ mm	l ₁ mm	l ₂ mm	l ₃ mm	d ₂ mm	a mm			ID			
4	40	2.84	56	12	18	3.5	2.7	3	2.3	● 145656			
6	32	3.5	56	13	20	4	3	3	2.8	● 155317			
8	32	4.16	63	14	21	4.5	3.4	3	3.45	● 155319			
										*N320-3 / N320V-3			

UNC ASME B1.1

HSSE



										N410-3	N420-4	N420V-4	N420TN-4	
										N410-3		31 62 73 74 91	N420-4	
										2B	2B	2B	2B	
$\varnothing'' d_1$ UNC	P TPI	d_1 mm	l_1 mm	l_2 mm	d_2 mm	a mm				ID	ID	ID	ID	
5/16	18	7.93	90	20	6	4.9	3	6.5	● 101997	● 102213	● 142742	● 196007		
3/8	16	9.52	100	22	7	5.5	3	8	● 101996	● 102212	● 142743	● 158317		
7/16	14	11.11	100	19	8	6.2	3	9.3		● 102215	● 142744	● 196008		
1/2	13	12.7	110	24	9	7	3	10.8	● 101993	● 102208	● 142745	● 143827		
9/16	12	14.28	110	28	11	9	3	12.2		● 102217				
5/8	11	15.87	110	30	12	9	3	13.6	● 101998	● 102214	● 142746	● 146391		
3/4	10	19.05	125	33	14	11	3	16.6	● 101995	● 102211	● 142747	● 146054		
7/8	9	22.22	140	36	18	14.5	3	19.5		● 102216	● 142748			
1	8	25.4	160	39	18	14.5	4	22.3	● 101994	● 102209	● 142749			
1 1/8	7	28.57	180	45	22	18	4	25		● 102205				
1 1/4	7	31.75	180	45	22	18	4	28.2		● 102204				
1 1/2	6	38.1	200	55	32	24	4	34		● 102203				
1 3/4	5	44.45	220	59	36	29	4	39.5	★ 101992	● 102206				
2	4.5	50.8	250	67	40	32	4	45.3		● 102210				

UNC ASME B1.1

≤ Ø 2.8 > Ø 2.8

PM HSSE

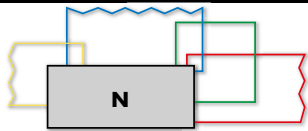
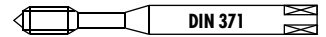

N360-3		63 72 73 74 81 91
N360V-3		11 12 32
N360TN-3		11 12 13 14 32
N360-3		63 72 73 74 81 91

N360-3	N360V-3	N360TN-3	N360-3
< 2.5 x D	< 2.5 x D	< 2.5 x D	< 2.5 x D

NEW

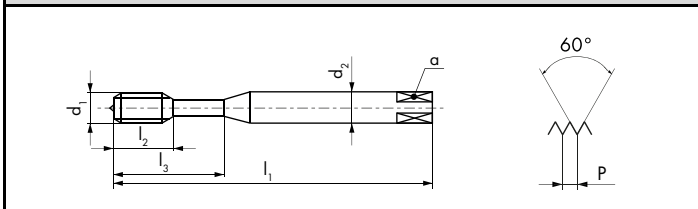

2B	2B	2B	3B UNC(J)

Ø" d ₁ UNC	P TPI	d ₁ mm	l ₁ mm	l ₂ mm	l ₃ mm	d ₂ mm	a mm			ID	ID	ID	ID
2	56	2.18	45	8		2.8	2.1	2	1.75	● 101673	● 148887		
3	48	2.51	50	9		2.8	2.1	2	2	● 101674			
4	40	2.84	56	5.5	18	3.5	2.7	3	¹ 2.25	● 101676	● 101725		● 155316
5	40	3.17	56	5.5	18	3.5	2.7	3	2.55	● 101677			
6	32	3.5	56	6.5	20	4	3	3	² 2.75	● 101679	● 101727	● 195998	● 155318
8	32	4.16	63	7.5	21	4.5	3.4	3	³ 3.4	● 101680	● 101728	● 150558	● 155320
10	24	4.82	70	9	25	6	4.9	3	3.8	● 101671	● 101723	● 195999	
12	24	5.48	80	11	30	6	4.9	3	4.4	● 101672			
1/4	20	6.35	80	11	30	7	5.5	3	5.1	● 101670	● 101722	● 196000	
5/16	18	7.93	90	12.5	35	8	6.2	3	6.5	● 101678	● 101726	● 196001	
3/8	16	9.52	100	14	39	10	8	3	8	● 101675	● 101724	● 164171	

UNJC
¹ 2.3
² 2.8
³ 3.45

UNC ASME B1.1

HSSE



										N460-3	N460V-3	N460TN-3
<p>N460-3 63 72 73 74 81 91</p> <p>N460V-3 11 12 32</p> <p>N460TN-3 11 12 13 14 32</p>												
										< 2.5 x D	< 2.5 x D	< 2.5 x D
										2.5 x P	2.5 x P	2.5 x P
										2B	2B	2B
$\emptyset'' d_1$ UNC	P TPI	d_1 mm	l_1 mm	l_2 mm	d_2 mm	a mm			ID	ID	ID	
7/16	14	11.11	100	14	8	6.2	3	9.3	● 102424	● 105135	● 196002	
1/2	13	12.7	110	14	9	7	3	10.8	● 102420	● 102497	● 157376	
9/16	12	14.28	110	14	11	9	3	12.2	● 102426	● 102502		
5/8	11	15.87	110	18	12	9	3	13.6	● 102423	● 102500	● 128252	
3/4	10	19.05	125	21	14	11	3	16.6	● 102422	● 102499	● 143519	
7/8	9	22.22	140	24	18	14.5	4	19.5	● 102425	● 102501		
1	8	25.4	160	27	18	14.5	4	22.3	● 102421	● 102498		
1 1/8	7	28.57	180	30	22	18	4	25	● 102418	● 102495		
1 1/4	7	31.75	180	30	22	18	4	28.2	● 102417	● 102494		
1 1/2	6	38.1	200	40	32	24	5	34	● 102416	● 102493		
1 3/4	5	44.45	220	44	36	29	5	39.5		● 128062		
2	4.5	50.8	250	52	40	32	5	45.3		● 128084		

UNC ASME B1.1

PM

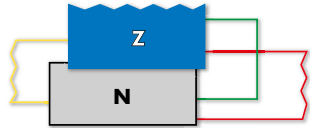
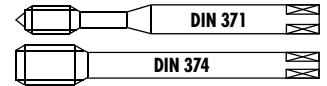

Z320V-4



11 12 13 21 32

Z320VS-4



11 12 13 14 21 22
23 32 61 63 94

Z420V-4



11 12 13 21 32

Z420VS-4



11 12 13 14 21 22
23 32 61 63 94

Z320V-4

Z320VS-4

Z420V-4

Z420VS-4

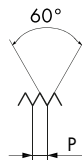
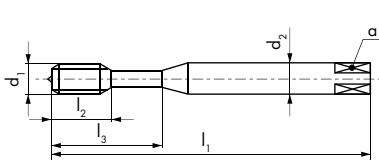

Ø" d ₁ UNC	P TPI	d ₁ mm	l ₁ mm	l ₂ mm	l ₃ mm	d ₂ mm	a mm		
* 2	56	2.18	45	9		2.8	2.1	2	1.75
4	40	2.84	56	12	18	3.5	2.7	3	2.25
6	32	3.5	56	13	20	4	3	3	2.75
8	32	4.16	63	14	21	4.5	3.4	3	3.4
10	24	4.82	70	15	25	6	4.9	3	3.8
1/4	20	6.35	80	17	30	7	5.5	3	5.1
5/16	18	7.93	90	20	35	8	6.2	3	6.5
3/8	16	9.52	100	22	39	10	8	3	8
7/16	14	11.11	100	19		8	6.2	3	9.3
1/2	13	12.7	110	24		9	7	3	10.8
5/8	11	15.87	110	30		12	9	3	13.6
3/4	10	19.05	125	33		14	11	4	16.6
7/8	9	22.22	140	36		18	14.5	4	19.5
1	8	25.4	160	39		18	14.5	4	22.3

ID

ID

ID

ID

● 142750

● 142751

● 142752 ● 111560

● 142753 ● 111561

● 142754 ● 111562

● 142755 ● 111563

● 142756 ● 111564

● 142757 ● 111565

● 196028

● 142758 ● 111566

● 142759 ● 111567

● 142760 ● 111568

● 142761

● 142762

*Z320V-3



UNC ASME B1.1

≤ Ø 2.8 > Ø 2.8

PM HSSE

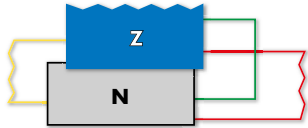
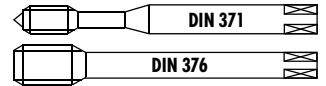

Z362V-3



Z462V-3



Z362V-3

Z462V-3

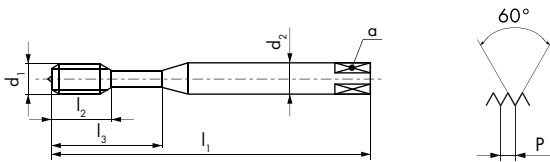

2B

2B

Ø" d ₁ UNC	P TPI	d ₁ mm	l ₁ mm	l ₂ mm	l ₃ mm	d ₂ mm	a mm			ID	ID
* 2	56	2.18	45	8		2.8	2.1	2	1.75	● 104695	
* 4	40	2.84	56	5.5	18	3.5	2.7	3	2.25	● 104697	
6	32	3.5	56	6.5	20	4	3	3	2.75	● 104699	
8	32	4.16	63	7.5	21	4.5	3.4	3	3.4	● 104700	
10	24	4.82	70	9	25	6	4.9	3	3.8	● 104694	
1/4	20	6.35	80	11	30	7	5.5	3	5.1	● 104693	
5/16	18	7.93	90	12.5	35	8	6.2	3	6.5	● 104698	
3/8	16	9.52	100	14	39	10	8	3	8	● 104696	
7/16	14	11.11	100	14		8	6.2	3	9.3		● 104757
1/2	13	12.7	110	14		9	7	3	10.8		● 104753
5/8	11	15.87	110	18		12	9	3	13.6		● 104756
3/4	10	19.05	125	21		14	11	3	16.6		● 104755
7/8	9	22.22	140	24		18	14.5	3	19.5		● 104758
1	8	25.4	160	27		18	14.5	4	22.3		● 104754

*Z360V-3

UNC ASME B1.1

PM

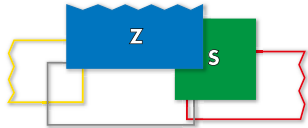
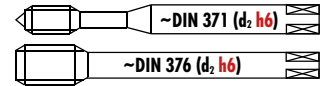

Z370VS-3

Z470VS-3

Z370VS-3



Z470VS-3



Z370VS-3



Z470VS-3

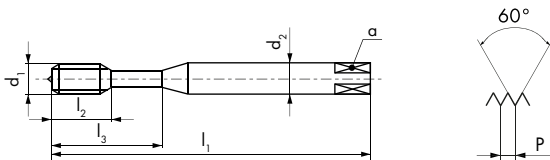

2BX

2BX

Ø" d ₁ UNC	P TPI	d ₁ mm	l ₁ mm	l ₂ mm	l ₃ mm	d ₂ h ₆ mm	a mm		
6	32	3.5	56	6.5	20	4 (h9)	3	3	2.75
8	32	4.16	63	7.5	21	4.5(h9)	3.4	3	3.4
10	24	4.82	70	9	25	6	4.9	3	3.8
1/4	20	6.35	80	11	30	* 6	* 4.9	3	5.1
5/16	18	7.93	90	12.5	35	8	6.2	3	6.5
3/8	16	9.52	100	14	39	10	8	3	8
7/16	14	11.11	100	14		8	6.2	3	9.3
1/2	13	12.7	110	14		* 10	* 8	4	10.8
5/8	11	15.87	110	18		12	9	4	13.6
3/4	10	19.05	125	21		14	11	4	16.6
1	8	25.4	160	27		16	12	4	22.3

ID

ID

- 166123
- 166124
- 166125
- 166126
- 166127
- 166128

- 166129
- 166130
- 166131
- 166132
- 175703

* Norme DC / * DC Norm/ * Norma DC

3B
UNC(J)

Ø" d ₁ UNC	P TPI	d ₁ mm	l ₁ mm	l ₂ mm	l ₃ mm	d ₂ h ₆ mm	a mm		
4	40	2.84	56	5.5	18	3.5(h9)	2.7	3	2.3
6	32	3.5	56	6.5	20	4 (h9)	3	3	2.8
8	32	4.16	63	7.5	21	4.5(h9)	3.4	3	3.45
1/4	20	6.35	80	11	30	* 6	* 4.9	3	5.2
5/16	18	7.93	90	12.5	35	8	6.2	3	6.7

ID









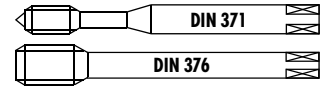

















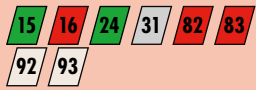

- 165114
- 165115
- 165116
- 165117
- 165118

* Norme DC / * DC Norm/ * Norma DC

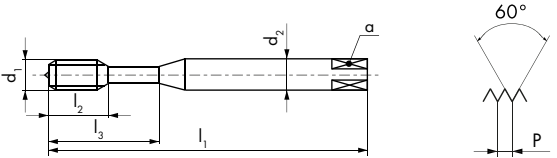
UNC ASME B1.1

PM



										H320-4	H420-4	H320TC-4	H420TC-4
H320-4													
H420-4												NEW	NEW
H320TC-4	 												
H420TC-4	 												
													
\emptyset " d ₁ UNC	P TPI	d ₁ mm	l ₁ mm	l ₂ mm	l ₃ mm	d ₂ mm	a mm			ID	ID	ID	ID
2	56	2.18	45	8		2.8	2.1	2	1.75	● 101221			
4	40	2.84	56	10	18	3.5	2.7	3	2.25	● 101223			
6	32	3.5	56	13	20	4	3	3	2.75	● 101225		● 196046	
8	32	4.16	63	14	21	4.5	3.4	3	3.4	● 101226		● 196047	
10	24	4.82	70	15	25	6	4.9	3	3.8	● 101220		● 196048	
1/4	20	6.35	80	17	30	7	5.5	3	5.1	● 101219		● 196049	
5/16	18	7.93	90	20	35	8	6.2	3	6.5	● 101224		● 143730	
3/8	16	9.52	100	22	39	10	8	3	8	● 101222		● 196050	
7/16	14	11.11	100	19		8	6.2	3	9.3		● 196051		● 196052
1/2	13	12.7	110	24		9	7	4	10.8		● 101290		● 143731
5/8	11	15.87	110	30		12	9	4	13.6		● 163741		● 196053
3/4	10	19.05	125	33		14	11	4	16.6		● 163743		● 196054

UNC ASME B1.1

PM

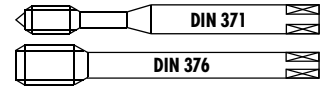

H350-3		15 16 62 64 82
H450-3		15 16 62 64 82
H350TC-3		15 16 24 31 82 83 92 93
H450TC-3		15 16 24 31 82 83 92 93

H350-3	H450-3	H350TC-3	H450TC-3
		NEW	NEW
< 1.5 x D	< 1.5 x D	< 1.5 x D	< 1.5 x D

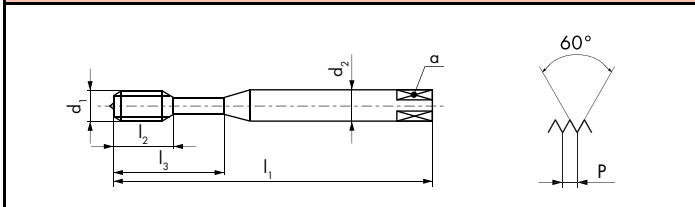

2B	2B	2B	2B

Ø" d ₁ UNC	P TPI	d ₁ mm	l ₁ mm	l ₂ mm	l ₃ mm	d ₂ mm	a mm			ID	ID	ID	ID
2	56	2.18	45	8		2.8	2.1	2	1.75	● 101258			
4	40	2.84	56	5.5	18	3.5	2.7	3	2.25	● 101260			
6	32	3.5	56	6.5	20	4	3	3	2.75	● 101262		● 196040	
8	32	4.16	63	7.5	21	4.5	3.4	3	3.4	● 101263		● 196041	
10	24	4.82	70	9	25	6	4.9	3	3.8	● 101257		● 196042	
1/4	20	6.35	80	11	30	7	5.5	3	5.1	● 101256		● 160585	
5/16	18	7.93	90	12.5	35	8	6.2	3	6.5	● 101261		● 160587	
3/8	16	9.52	100	14	39	10	8	3	8	● 101259		● 162106	
7/16	14	11.11	100	14		8	6.2	3	9.3		● 101330		● 196043
1/2	13	12.7	110	14		9	7	4	10.8		● 101326		● 160586
5/8	11	15.87	110	18		12	9	4	13.6		● 101329		● 196044
3/4	10	19.05	125	21		14	11	4	16.6		● 101328		● 196045
1	8	25.4	160	27		18	14.5	4	22.3		● 101327		

UNC ASME B1.1

PM

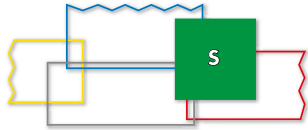
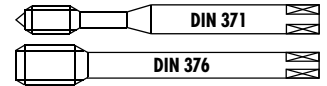

S320VS-4



VS

13 15 16 22 23 24
52

S420VS-4



VS

13 15 16 22 23 24
52

S320VS-4

S420VS-4

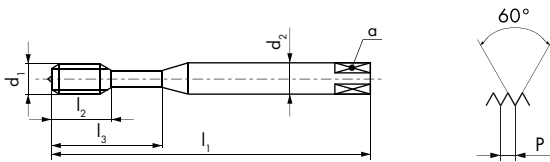

2B

2B

$\emptyset'' d_1$ UNC	P TPI	d_1 mm	l_1 mm	l_2 mm	l_3 mm	d_2 mm	a mm		
6	32	3.5	56	13	20	4	3	3	2.75
8	32	4.16	63	14	21	4.5	3.4	3	3.4
1/4	20	6.35	80	17	30	7	5.5	3	5.1
5/16	18	7.93	90	20	35	8	6.2	3	6.5
3/8	16	9.52	100	22	39	10	8	3	8
1/2	13	12.7	110	24		9	7	4	10.8
5/8	11	15.87	110	30		12	9	4	13.6
3/4	10	19.05	125	33		14	11	4	16.6

ID

ID

● 111587

● 111588

● 111590

● 111591

● 111592

● 111593

● 111594

● 111595

3B
UNC(J)

$\emptyset'' d_1$ UNC	P TPI	d_1 mm	l_1 mm	l_2 mm	l_3 mm	d_2 mm	a mm		
4	40	2.84	56	12	18	3.5	2.7	3	2.3
6	32	3.5	56	13	20	4	3	3	2.8
8	32	4.16	63	14	21	4.5	3.4	3	3.45
1/4	20	6.35	80	17	30	7	5.5	3	5.2
5/16	18	7.93	90	20	35	8	6.2	3	6.7

ID

● 165314

● 165315

● 165316

● 165317

* 143761

UNC ASME B1.1

PM

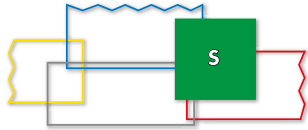
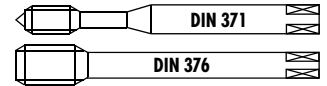

S360VS-3



13 15 16 22 23 24
52

S460VS-3



13 15 16 22 23 24
52

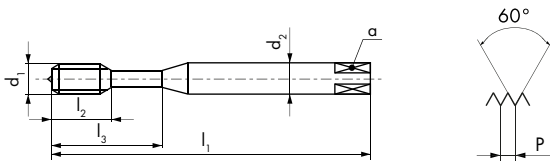

S360VS-3

S460VS-3



2B

2B

\emptyset " d ₁ UNC	P TPI	d ₁ mm	l ₁ mm	l ₂ mm	l ₃ mm	d ₂ mm	a mm		
6	32	3.5	56	6.5	20	4	3	3	2.75
8	32	4.16	63	7.5	21	4.5	3.4	3	3.4
1/4	20	6.35	80	11	30	7	5.5	3	5.1
5/16	18	7.93	90	12.5	35	8	6.2	3	6.5
3/8	16	9.52	100	14	39	10	8	3	8
1/2	13	12.7	110	14		9	7	4	10.8

ID

ID

• 111530

• 111531

• 111533

• 111534

• 111535

• 111537

aero

SA320-4



15 16 52 64

SA350-3



15 16 52 64

TL320VS-4



41 42

TL351VS-3



41 42

SA320-4

SA350-3

TL320VS-4

TL351VS-3

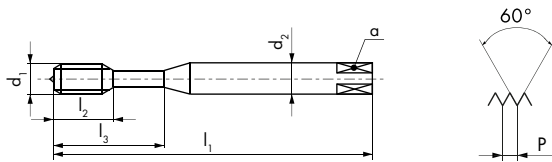

Ø" d ₁ UNC	P TPI	d ₁ mm	l ₁ mm	l ₂ mm	l ₃ mm	d ₂ mm	a mm		
4	40	2.84	56	12		3.5	2.7	3	2.25
5	40	3.17	56	12		3.5	2.7	3	2.55
6	32	3.5	56	13		4	3	3	2.75
8	32	4.16	63	14		4.5	3.4	3	3.4
10	24	4.82	70	15		6	4.9	3	3.8
1/4	20	6.35	80	15	23	7	5.5	3	5.1
5/16	18	7.93	90	18	29	8	6.2	3	6.5
3/8	16	9.52	100	20	33	10	8	3	8

ID	ID	ID	ID
● 147271	● 149003		● 152018
		* 152023	* 152024
● 149055	● 149057	* 152027	● 152028
● 149093	● 149095		● 152037
● 149125	* 149127		
● 149222	● 149224		● 127972
● 149269	● 149271		● 152068
● 149346	● 149348	* 152084	● 152085

Ø" d ₁ UNC	P TPI	d ₁ mm	l ₁ mm	l ₂ mm	l ₃ mm	d ₂ mm	a mm		
4	40	2.84	56	12		3.5	2.7	3	2.3
6	32	3.5	56	13		4	3	3	2.8
8	32	4.16	63	14		4.5	3.4	3	3.45
10	24	4.82	70	15		6	4.9	3	3.9
1/4	20	6.35	80	15	23	7	5.5	3	5.2
5/16	18	7.93	90	18	29	8	6.2	3	6.7
3/8	16	9.52	100	20	33	10	8	3	8.1

ID	ID	ID	ID
● 149005	● 149007	* 148804	● 150194
● 149059	● 149061	* 152029	● 150210
● 149097	● 149099		● 152039
			* 152045
● 149226	● 149228	* 152063	● 152064
● 149273	● 149275	* 152069	● 152070
● 149350	● 149352		● 152087

UNC ASME B1.1

PM

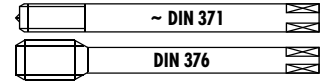

aero

SA420-4



15 16 52 64

SA450-3



15 16 52 64

SA390-3



16 53

SA420-4

SA450-3

SA390-3

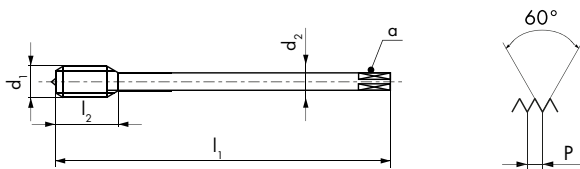

Ø" d ₁ UNC	P TPI	d ₁ mm	l ₁ mm	l ₂ mm	d ₂ mm	a mm		
1/2	13	12.7	110	24	9	7	4	10.8
5/8	11	15.87	110	30	12	9	4	13.6

ID	ID
● 152247	● 152252
● 152249	● 152254

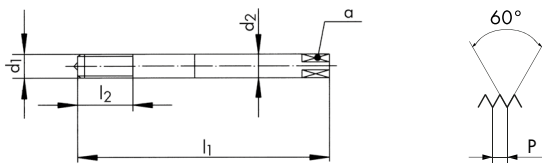

Ø" d ₁ UNC	P TPI	d ₁ mm	l ₁ mm	l ₂ mm	d ₂ mm	a mm		
4	40	2.84	56	12	3.5	2.7	3	2.3
6	32	3.5	56	13	4	3	3	2.8
8	32	4.16	63	14	4.5	3.4	3	3.45
10	24	4.82	70	15	6	4.9	3	3.9
1/4	20	6.35	80	20	7	5.5	3	5.2
5/16	18	7.93	90	25	8	6.2	3	6.7
3/8	16	9.52	100	30	10	8	3	8.1

ID

- 149652
- 149666
- 149677
- 149685
- 149713
- 149726
- 149747



PM

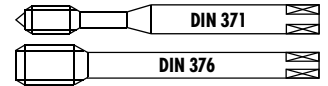

QTAP

Q320VS-4

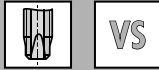

Q420VS-4



Q323VS-4



Q423VS-4



- 11 12 13 14
- 15 21 22 23
- 24 31 32 51
- 52 61 62 63
- 64 71 72 73
- 74 81 82 83
- 91 92 94

Q320VS-4

Q420VS-4

Q323VS-4

Q423VS-4



NEW



NEW



NEW



NEW

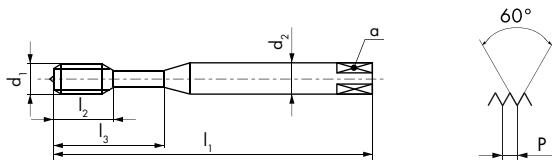

2B



2B



2B



2B

Ø" d ₁ UNC	P TPI	d ₁ mm	l ₁ mm	l ₂ mm	l ₃ mm	d ₂ mm	a mm		
6	32	3.5	56	13	20	4	3	3	2.75
8	32	4.16	63	14	21	4.5	3.4	3	3.4
10	24	4.82	70	15	25	6	4.9	3	3.8
1/4	20	6.35	80	17	30	7	5.5	3	5.1
5/16	18	7.93	90	20	35	8	6.2	3	6.5
3/8	16	9.52	100	22	39	10	8	3	8
1/2	13	12.7	110	24		9	7	3	10.8
5/8	11	15.87	110	30		12	9	3	13.6
3/4	10	19.05	125	33		14	11	4	16.6
7/8	9	22.22	140	36		18	14.5	4	19.5
1	8	25.4	160	39		18	14.5	4	22.3

ID

ID

ID

ID

● 196275

● 196320

● 196276

● 196321

● 196277

● 196322

● 196278

● 196323

● 196279

● 196324

● 196280

● 196325

● 196281

● 196326

● 196282

● 196327

● 196283

● 196328

● 196284

● 196329

● 196285

● 196330



≤ Ø 16 > Ø 16

PM HSSE

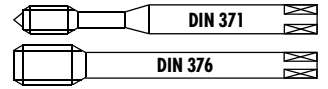

QTAP

Q360VS-3



Q460VS-3



Q363VS-3



Q463VS-3



Q360VS-3

Q460VS-3

Q363VS-3

Q463VS-3



NEW



NEW



NEW



NEW

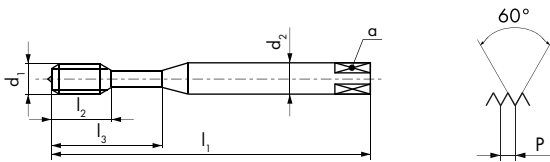

2B

2B

2B

2B

Ø" d ₁ UNC	P TPI	d ₁ mm	l ₁ mm	l ₂ mm	l ₃ mm	d ₂ mm	a mm		
6	32	3.5	56	6.5	20	4	3	3	2.75
8	32	4.16	63	7.5	21	4.5	3.4	3	3.4
10	24	4.82	70	9	25	6	4.9	3	3.8
1/4	20	6.35	80	11	30	7	5.5	3	5.1
5/16	18	7.93	90	12.5	35	8	6.2	3	6.5
3/8	16	9.52	100	14	39	10	8	3	8
7/16	14	11.11	100	14		8	6.2	3	9.3
1/2	13	12.7	110	14		9	7	3	10.8
5/8	11	15.87	110	18		12	9	3	13.6
3/4	10	19.05	125	21		14	11	3	16.6
7/8	9	22.22	140	24		18	14.5	3	19.5
1	8	25.4	160	27		18	14.5	4	22.3

ID

ID

ID

ID

● 196286

● 196331

● 196287

● 196332

● 196288

● 196333

● 196289

● 197622

● 196290

● 197623

● 196291

● 197624

● 196292 ● 197625

● 196293 ● 197626

● 196294 ● 197627

● 196295 ● 197628

● 196296 ● 197629

● 196297 ● 197630



Uniquement pour taraudage synchrone
Nur für Synchrobearbeitung
Only for rigid tapping
Solo per mescolatura sincrona
Solo para resacado sincronizado
Только для rigid tapping

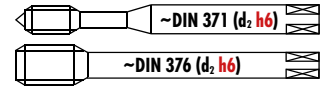

RTS

Rigid Tapping Synchro

RTS320VS-4

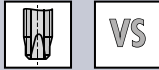

RTS420VS-4



RTS362VS-3



RTS462VS-3



RTS320VS-4

RTS420VS-4

RTS362VS-3

RTS462VS-3

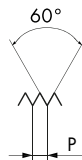
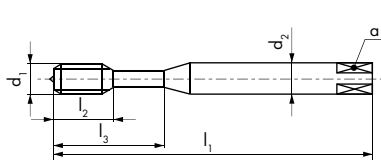

Ø" d ₁ UNC	P TPI	d ₁ mm	l ₁ mm	l ₂ mm	l ₃ mm	d ₂ h6 mm	a mm		
6	32	3.5	56	6.5	20	4 (h9)	3	3	2.75
8	32	4.16	63	7.5	21	4.5(h9)	3.4	3	3.4
10	24	4.82	70	9	25	6	4.9	3	3.8
1/4	20	6.35	80	11	30	* 6	* 4.9	3	5.1
5/16	18	7.93	90	12.5	35	8	6.2	3	6.5
3/8	16	9.52	100	14	39	10	8	3	8
1/2	13	12.7	110	14		* 10	* 8	3	10.8

ID	ID	ID	ID
● 157395		● 157402	
● 157396		● 157403	
● 157397		● 157404	
● 157398		● 157405	
● 157399		● 157406	
● 157400		● 157407	
	● 157401		● 157408

* Norme DC / * DC Norm/ * Norma DC



sur demande
auf Anfrage
on request
su richiesta
sobre pedido
no zapyty

UNC ASME B1.1

≤ Ø 2.8 > Ø 2.8

PM HSS

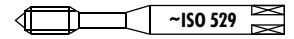

										N1110-1	N1110-2	N1110-3	N1110-S	
N1110-1														
N1110-2														
N1110-3			31	62	73	74	91							
N1110-S														
Ø" d ₁ UNC	P TPI	d ₁ mm	l ₁ mm	l ₂ mm	l ₃ mm	d ₂ mm	a mm			ID	ID	ID	ID	
2	56	2.18	45	9.5		2.8	2.1	3	1.75	● 102799	● 102885	● 102998	● 111067	
3	48	2.51	45	9.5		2.8	2.1	3	2	★ 102800	★ 102886	★ 102999	★ 111068	
4	40	2.84	48	11	18	3.15	2.5	3	2.25	● 102802	● 102888	● 103001	● 111070	
5	40	3.17	48	11	18	3.15	2.5	3	2.55			● 103002		
6	32	3.5	50	13	20	3.55	2.8	3	2.75	● 102805	● 102891	● 103004	● 111073	
8	32	4.16	53	13	21	4.5	3.55	3	3.4	● 102806	● 102892	● 103005	● 111074	
10	24	4.82	58	16	25	5	4	3	3.8	● 102797	● 102883	● 102996	● 111065	
1/4	20	6.35	66	19	30	6.3	5	3	5.1	● 102796	● 102882	● 102995	● 111064	
5/16	18	7.93	72	22	35	8	6.3	3	6.5	● 102804	● 102890	● 103003	● 111072	
3/8	16	9.52	80	24	39	10	8	3	8	● 102801	● 102887	● 103000	● 111069	

UNC ASME B1.1

HSS

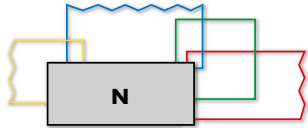
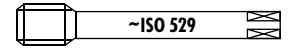

	N1210-1	N1210-2	N1210-3	N1210-S
N1210-1				
N1210-2				
N1210-3				
N1210-S				

31 62 73 74 91

			2B	2B

\emptyset " d_1 UNC	P TPI	d_1 mm	l_1 mm	l_2 mm	d_2 mm	a mm			ID	ID	ID	ID
7/16	14	11.11	85	22	8	6.3	3	9.3	● 103392	● 103466	● 103606	● 111236
1/2	13	12.7	89	24	9	7.1	3	10.8	● 103387	● 103461	● 103601	● 111229
5/8	11	15.87	102	32	12.5	10	3	13.6	● 103391	● 103465	● 103605	● 111235
3/4	10	19.05	112	33	14	11.2	3	16.6	● 103390	● 103464	● 103604	● 111234
1	8	25.4	130	45	18	14	4	22.3	● 103388	● 103462	● 103602	● 111230











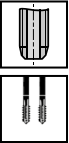

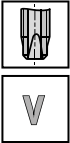
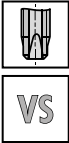
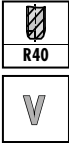
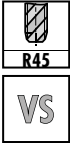

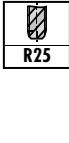







UNF, UNEF UNS, UN

Указатель — Машинные метчики ASME B1.1
Directory — Machine taps ASME B1.1



















		N						
Характеристики Characteristics								
					NEW			NEW
Типы отверстий Hole type								
		N310-3	N320-3 N320-4	N320V-4	N320TN-4	N360-3	N360V-3	N360TN-3
Длинный по DIN DIN long	DIN 371	176	176	176	176	178	178	178
Короткий по ISO ISO short	ISO 529							
Класс точности Tolerance	UNF 2B	176	176	176	176	178	178	178
Класс точности Tolerance	UNF(J) 3B		176			178		
Класс точности Tolerance	UNEF 2B							
Класс точности Tolerance	UNS 2B							
Класс точности Tolerance	UN 2B							
		N410-3	N420-4	N420V-4	N420TN-4	N460-3	N460V-3	N460TN-3
Длинный по DIN DIN long	DIN 374/~DIN 376	177 / 199	177	177	177	179 / 199	179 / 199	179
Короткий по ISO ISO short	ISO 529							
Класс точности Tolerance	UNF 2B	177	177	177	177	179	179	179
Класс точности Tolerance	UNF(J) 3B		177			179		
Класс точности Tolerance	UNEF 2B							
Класс точности Tolerance	UNS 2B	199				199	199	
Класс точности Tolerance	UN 2B					199	199	

UNF, UNEF

Указатель — Машинные и ручные метчики ASME B1.1
 Directory — Machine and hand taps ASME B1.1

N		Z				H		
		 V	 VS	 R40 V	 R45 VS		 TiCN	 R25
			 NEW				 NEW	
								
N1110 -1 -3 -S	N1120-4	Z320V-4	Z320VS-4	Z360V-3	Z370VS-3	H320-4	H320TC-4	H350-3
196 / 198	198	180	180	181	182	184	184	185
196		180	180	181	182	184	184	185
198	198				182			
N1210 -1 -3 -S	N1220-4	Z420V-4	Z420VS-4	Z460V-3	Z470VS-3	H420-4	H420TC-4	H450-3
197 / 198	198	180	180	181	182	184	184	185
197		180	180	181	182	184	184	185
198	198							

	H	S		SA			TL	
Характеристики Characteristics	 R25 TiCN	 VS	 R35 VS		 R15	 R10	 R15 VS	
	 NEW							
Типы отверстий Hole type								
	H350TC-3	S320VS-4	S360VS-3	SA320-4	SA350-3	SA390-3	TL351VS-3	
Длинный по DIN DIN long	DIN 371	185	186	186	188	188	190	188
Короткий по ISO ISO short	ISO 529							
Класс точности Tolerance	UNF 2B	185			188	188		188
Класс точности Tolerance	UNF(J) 3B		186	186	188	188	190	188
Класс точности Tolerance	UNEF 2B							
Класс точности Tolerance	UNS 2B							
Класс точности Tolerance	UN 2B							
	H450TC-3	S420VS-4	S460VS-3	SA420-4	SA450-3		TL451VS-3	
Длинный по DIN DIN long	DIN 374/~DIN 376	185	186	186	189	189		189
Короткий по ISO ISO short	ISO 529							
Класс точности Tolerance	UNF 2B	185			189	189		
Класс точности Tolerance	UNF(J) 3B		186	186	189	189		189
Класс точности Tolerance	UNEF 2B							
Класс точности Tolerance	UNS 2B							
Класс точности Tolerance	UN 2B							

QTAP				RTS	
					
VS	VS	VS	VS	VS	VS
					
NEW	NEW	NEW	NEW		
					
Q320VS-4	Q323VS-4	Q360VS-3	Q363VS-3	RTS320VS-4	RTS362VS-3
192	192	193	193	194	194
192	192	193	193	194	194
Q420VS-4	Q423VS-4	Q460VS-3	Q463VS-3	RTS420VS-4	RTS462VS-3
192	192	193	193	194	194
192	192	193	193	194	194

UNF ASME B1.1

≤ Ø 2.8 > Ø 2.8

PM HSSE

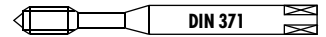

										N310-3	N320-4	N320V-4	N320TN-4
N310-3													
N320-4													
N320V-4													
N320TN-4													
										2.5 x P	4 x P	4 x P	4 x P
										2B	2B	2B	2B
Ø" d ₁ UNF	P TPI	d ₁ mm	l ₁ mm	l ₂ mm	l ₃ mm	d ₂ mm	a mm			ID	ID	ID	ID
* 0	80	1.52	40	7		2.5	2.1	2	1.2		● 101475		
* 2	64	2.18	45	9		2.8	2.1	2	1.8		● 101477		
4	48	2.84	56	12	18	3.5	2.7	3	2.35		● 128847		
5	44	3.17	56	12	18	3.5	2.7	3	2.6		● 142764		
6	40	3.5	56	13	20	4	3	3	2.9		● 101519	● 142765	
8	36	4.16	63	14	21	4.5	3.4	3	3.5		● 101520		
10	32	4.82	70	15	25	6	4.9	3	4.05		● 101517	● 142766	● 196014
12	28	5.48	80	17	30	6	4.9	3	4.6		● 101518		
1/4	28	6.35	80	17	30	7	5.5	3	5.5	● 101453	● 101516	● 142767	● 158791
Ø" d ₁ UNF	P TPI	d ₁ mm	l ₁ mm	l ₂ mm	l ₃ mm	d ₂ mm	a mm			ID			
10	32	4.82	70	15	25	6	4.9	3	4.15	● 135506			
1/4	28	6.35	80	17	30	7	5.5	3	5.55	● 155323			
*N320-3													

UNF ASME B1.1

HSSE

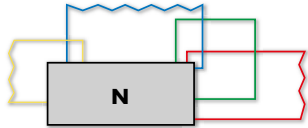

N410-3		31 62 73 74 91
N420-4		62 63 64 72 73 74 81 91
N420V-4		11 12 31 32
N420TN-4		11 12 13 14 32

N410-3	N420-4	N420V-4	N420TN-4
			NEW

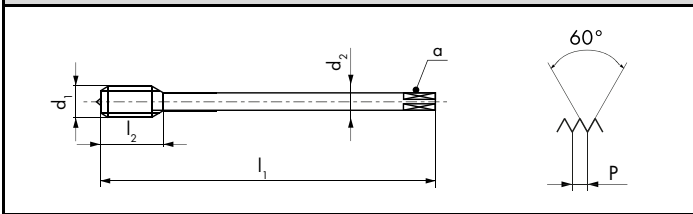

2B	2B	2B	2B

Ø" d ₁ UNF	P TPI	d ₁ mm	l ₁ mm	l ₂ mm	d ₂ mm	a mm		
5/16	24	7.93	90	20	6	4.9	3	6.9
3/8	24	9.52	100	22	7	5.5	3	8.5
7/16	20	11.11	100	19	8	6.2	3	9.8
1/2	20	12.7	100	24	9	7	3	11.4
9/16	18	14.28	100	24	11	9	3	12.9
5/8	18	15.87	100	26	12	9	3	14.5
3/4	16	19.05	125	33	14	11	4	17.5
7/8	14	22.22	140	36	18	14.5	4	20.4
1	12	25.4	160	39	18	14.5	4	23.3
1 1/8	12	28.57	180	39	22	18	4	26.5
1 1/4	12	31.75	180	39	22	18	4	29.7
1 3/8	12	34.92	200	36	28	22	4	32.8
1 1/2	12	38.1	200	41	32	24	4	36

ID	ID	ID	ID
● 102004	● 102223	● 142774	● 196015
● 102003	● 102222	● 142775	● 196016
● 102006	● 102225	● 142776	● 196017
● 102000	● 102219	● 142777	● 196018
	● 102227		
● 102005	● 102224	● 142778	● 196019
● 102002	● 102221	● 142779	● 185919
	● 102226		
	● 102220	● 142780	
	● 142773		
	● 102218		
	● 105137		
	● 105138		

									3B UNF(J)
--	--	--	--	--	--	--	--	--	------------------

Ø" d ₁ UNF	P TPI	d ₁ mm	l ₁ mm	l ₂ mm	d ₂ mm	a mm		
5/16	24	7.93	90	20	6	4.9	3	7
3/8	24	9.52	100	22	7	5.5	3	8.6
7/16	20	11.11	100	19	8	6.2	3	10
1/2	20	12.7	100	24	9	7	3	11.55

ID
● 155328
● 155326
● 155330
● 155321

UNF ASME B1.1

HSSE

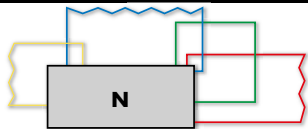
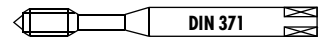

N360-3		63 72 73 74 81 91
N360V-3		11 12 32
N360TN-3		11 12 13 14 32

N360-3	N360V-3	N360TN-3	
		NEW	

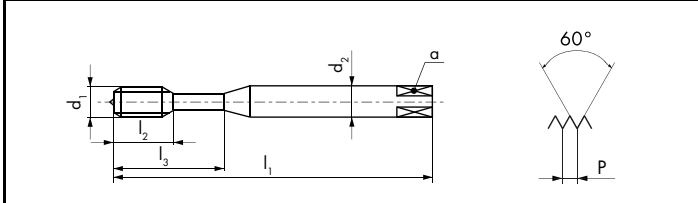

2B	2B	2B

\emptyset " d_1 UNF	P TPI	d_1 mm	l_1 mm	l_2 mm	l_3 mm	d_2 mm	a mm			ID	ID	ID
6	40	3.5	56	6.5	20	4	3	3	2.9	● 101686		
10	32	4.82	70	9	25	6	4.9	3	4.05	● 101682	● 101730	● 196009
12	28	5.48	80	11	30	6	4.9	3	4.6	● 101683		
1/4	28	6.35	80	11	30	7	5.5	3	5.5	● 101681	● 101729	● 146137
5/16	24	7.93	90	12.5	35	8	6.2	3	6.9	● 101685	● 101732	● 196010
3/8	24	9.52	100	14	39	10	8	3	8.5	● 101684	● 101731	● 196011

										3B UNF(J)		
--	--	--	--	--	--	--	--	--	--	---------------------	--	--

\emptyset " d_1 UNF	P TPI	d_1 mm	l_1 mm	l_2 mm	l_3 mm	d_2 mm	a mm			ID
10	32	4.82	70	9	25	6	4.9	3	4.15	● 155325
1/4	28	6.35	80	11	30	7	5.5	3	5.55	● 155324
5/16	24	7.93	90	12.5	35	8	6.2	3	7	● 155329
3/8	24	9.52	100	14	39	10	8	3	8.6	● 155327

UNF ASME B1.1

HSSE

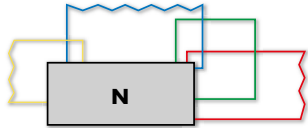

N460-3		63 72 73 74 81 91
N460V-3		11 12 32
N460TN-3		11 12 13 14 32

N460-3	N460V-3	N460TN-3
< 2.5 x D	< 2.5 x D	< 2.5 x D

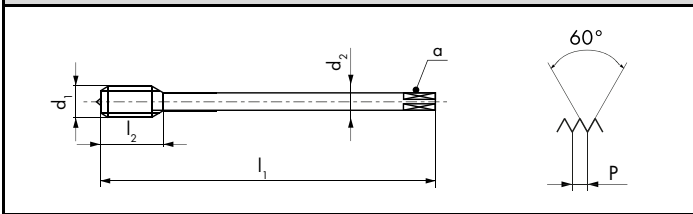

2B	2B	2B

Ø" d ₁ UNF	P TPI	d ₁ mm	l ₁ mm	l ₂ mm	d ₂ mm	a mm		
7/16	20	11.11	100	14	8	6.2	3	9.8
1/2	20	12.7	100	14	9	7	3	11.4
9/16	18	14.28	100	14	11	9	3	12.9
5/8	18	15.87	100	14	12	9	3	14.5
3/4	16	19.05	125	18	14	11	4	17.5
7/8	14	22.22	140	20	18	14.5	4	20.4
1	12	25.4	160	27	18	14.5	4	23.3
1 1/8	12	28.57	180	24	22	18	4	26.5
1 1/4	12	31.75	180	24	22	18	4	29.7
1 1/2	12	38.1	200	30	32	24	5	36

ID	ID	ID
● 102434	● 142781	● 158885
● 102430	● 102503	● 196012
● 102436	● 143422	
● 102433	● 143097	● 196013
● 102432	● 102505	● 142568
● 102435	● 144714	
● 102431	● 102504	
● 102429	● 144414	
● 102428	● 151709	
● 102427	● 148793	

3B UNF(J)

Ø" d ₁ UNF	P TPI	d ₁ mm	l ₁ mm	l ₂ mm	d ₂ mm	a mm		
7/16	20	11.11	100	14	8	6.2	3	10
1/2	20	12.7	100	14	9	7	3	11.55

ID
● 155331
● 155322

UNF ASME B1.1

PM

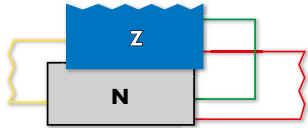
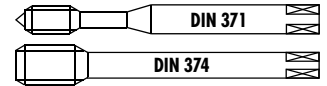

Z320V-4		V	11 12 13 21 32
Z420V-4		V	11 12 13 21 32
Z320VS-4		VS	11 12 13 14 21 22 23 32 61 63 94
Z420VS-4		VS	11 12 13 14 21 22 23 32 61 63 94

Z320V-4	Z420V-4	Z320VS-4	Z420VS-4
---------	---------	----------	----------

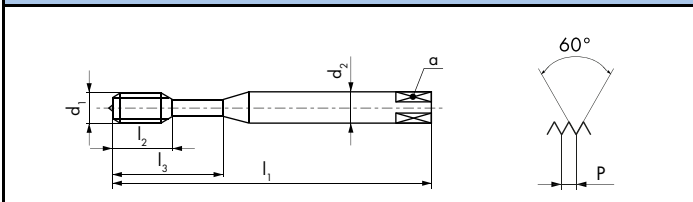
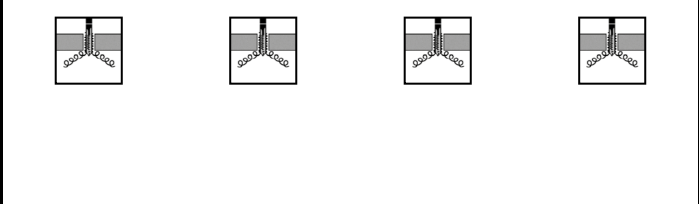

2B	2B	2B	2B

Ø" d ₁ UNF	P TPI	d ₁ mm	l ₁ mm	l ₂ mm	l ₃ mm	d ₂ mm	a mm			ID	ID	ID	ID
10	32	4.82	70	15	25	6	4.9	3		● 142783		● 128685	
1/4	28	6.35	80	17	30	7	5.5	3		● 142784		● 128596	
5/16	24	7.93	90	20	35	8	6.2	3		● 142785		● 128869	
3/8	24	9.52	100	22	39	10	8	3		● 142786		● 128814	
7/16	20	11.11	100	19		8	6.2	3			● 142787		● 128960
1/2	20	12.7	100	24		9	7	3			● 142788		● 128556
5/8	18	15.87	100	26		12	9	3					● 196031
3/4	16	19.05	125	33		14	11	4					● 196032

UNF ASME B1.1

HSSE

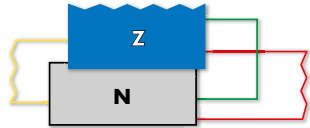
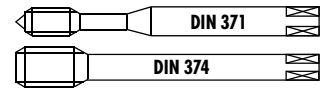

Z360V-3



12 21 32

Z460V-3



12 21 32

Z360V-3

Z460V-3

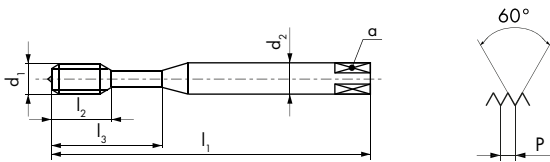

2B

2B

Ø" d ₁ UNF	P TPI	d ₁ mm	l ₁ mm	l ₂ mm	l ₃ mm	d ₂ mm	a mm		
10	32	4.82	70	9	25	6	4.9	3	4.05
1/4	28	6.35	80	11	30	7	5.5	3	5.5
5/16	24	7.93	90	12.5	35	8	6.2	3	6.9
3/8	24	9.52	100	14	39	10	8	3	8.5
7/16	20	11.11	100	14		8	6.2	3	9.8
1/2	20	12.7	100	14		9	7	3	11.4
5/8	18	15.87	100	14		12	9	3	14.5
3/4	16	19.05	125	18		14	11	4	17.5

ID

ID

● 104680

● 104679

● 104682

● 104681

● 104741

● 104738

● 104740

● 104739

UNF ASME B1.1

PM

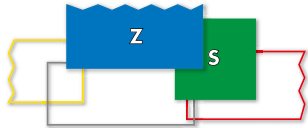
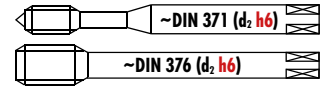

Z370VS-3				
Z470VS-3				
Z370VS-3				
Z470VS-3				

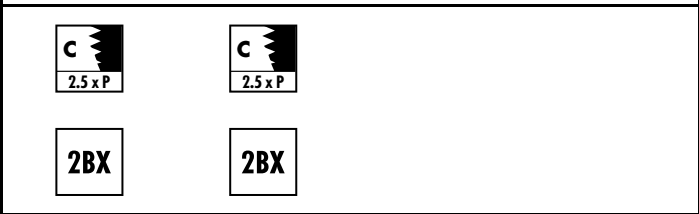
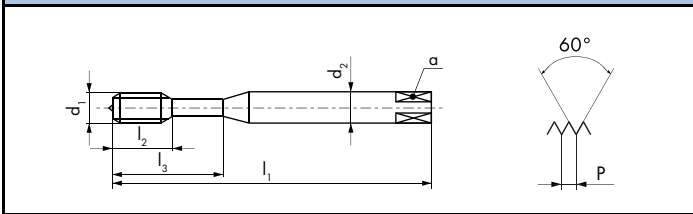
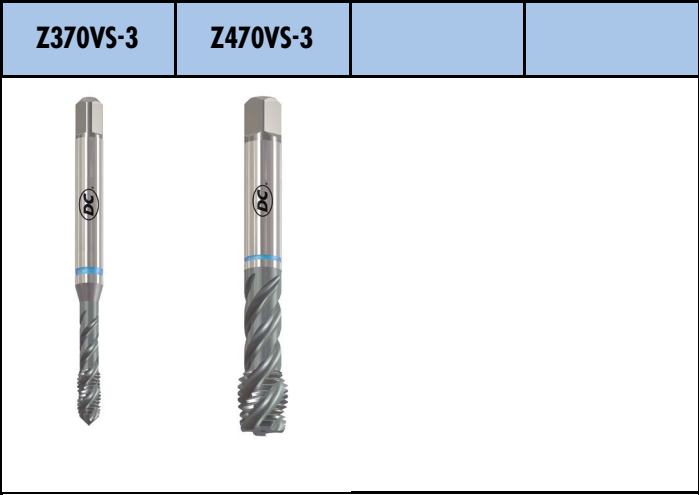

Ø" d ₁ UNF	P TPI	d ₁ mm	l ₁ mm	l ₂ mm	l ₃ mm	d ₂ h ₆ mm	a mm		
10	32	4.82	70	9	25	6	4.9	3	4.05
1/4	28	6.35	80	11	30	* 6	* 4.9	3	5.5
5/16	24	7.93	90	12.5	35	8	6.2	3	6.9
3/8	24	9.52	100	14	39	10	8	3	8.5
7/16	20	11.11	100	14		8	6.2	3	9.8
1/2	20	12.7	110	14		* 10	* 8	4	11.4
5/8	18	15.87	110	18		12	9	4	14.5
3/4	16	19.05	125	21		14	11	4	17.5

* Norme DC / * DC Norm/ * Norma DC

ID	ID
● 166136	
● 166135	
● 166134	
● 166133	
	● 166138
	● 166137
	● 196029
	● 196030



Ø" d ₁ UNF	P TPI	d ₁ mm	l ₁ mm	l ₂ mm	l ₃ mm	d ₂ h ₆ mm	a mm		
10	32	4.82	70	9	25	6	4.9	3	4.15
1/4	28	6.35	80	11	30	* 6	* 4.9	3	5.55
5/16	24	7.93	90	12.5	35	8	6.2	3	7
3/8	24	9.52	100	14	39	10	8	3	8.6

* Norme DC / * DC Norm/ * Norma DC

ID
● 165121
● 165122
● 165123
● 165124

MJ, UNJC, UNJF

наши машинные метчики с радиусом по наружному диаметру обобщены в отдельной главе со страницы 44.



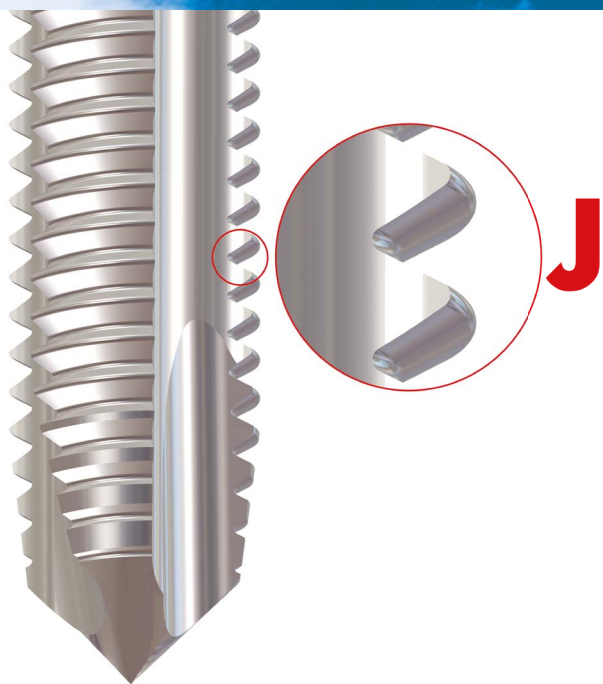





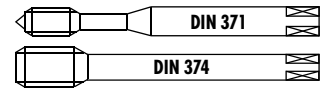

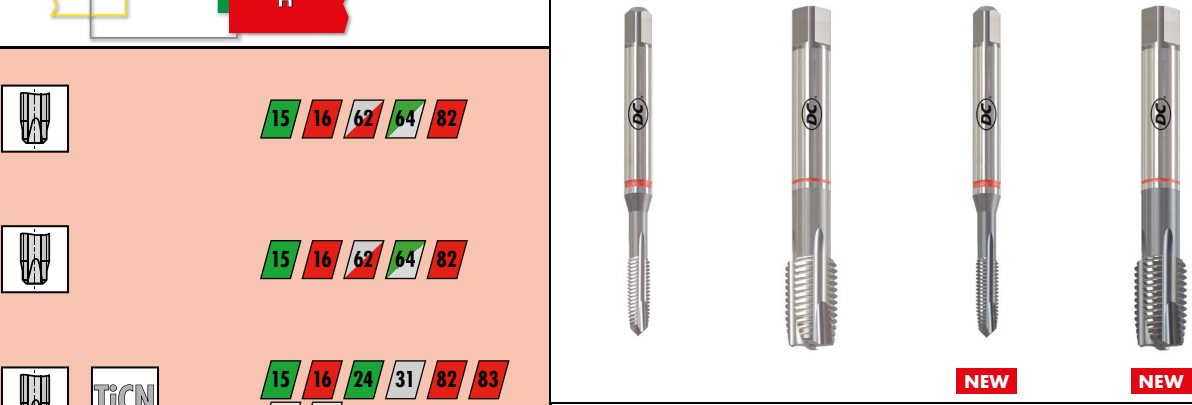

Our machine taps with radius on the outside diameter summarised in a separate chapter from page 44.

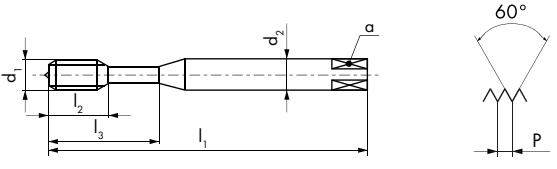

UNF ASME B1.1

PM



										H320-4	H420-4	H320TC-4	H420TC-4
													
H320-4		15 16 62 64 82											
H420-4		15 16 62 64 82											
H320TC-4		TiCN	15 16 24 31 82 83 92 93										
H420TC-4		TiCN	15 16 24 31 82 83 92 93										
										 2B	 2B	 2B	 2B
Ø" d ₁ UNF	P TPI	d ₁ mm	l ₁ mm	l ₂ mm	l ₃ mm	d ₂ mm	a mm			ID	ID	ID	ID
10	32	4.82	70	15	25	6	4.9	3	4.05	● 101228		● 196060	
1/4	28	6.35	80	17	30	7	5.5	3	5.5	● 101227		● 142613	
5/16	24	7.93	90	20	35	8	6.2	3	6.9	● 105139		● 196061	
3/8	24	9.52	100	22	39	10	8	3	8.5	● 101229		● 196062	
7/16	20	11.11	100	19		8	6.2	3	9.8		● 147253		● 196063
1/2	20	12.7	100	24		9	7	4	11.4		● 101291		● 196064
5/8	18	15.87	100	26		12	9	4	14.5		● 101293		● 196065
3/4	16	19.05	125	33		14	11	4	17.5		● 101292		● 196066

UNF ASME B1.1

PM

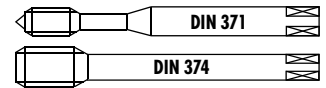

H350-3		15 16 62 64 82
H450-3		15 16 62 64 82
H350TC-3		15 16 24 31 82 83 92 93
H450TC-3		15 16 24 31 82 83 92 93

H350-3	H450-3	H350TC-3	H450TC-3
		NEW	NEW
< 1.5 x D	< 1.5 x D	< 1.5 x D	< 1.5 x D

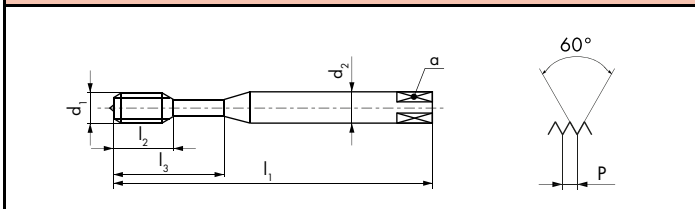

2B	2B	2B	2B

Ø" d ₁ UNF	P TPI	d ₁ mm	l ₁ mm	l ₂ mm	l ₃ mm	d ₂ mm	a mm			ID	ID	ID	ID
10	32	4.82	70	9	25	6	4.9	3	4.05	● 101265		● 196055	
1/4	28	6.35	80	11	30	7	5.5	3	5.5	● 101264		● 146714	
5/16	24	7.93	90	12.5	35	8	6.2	3	6.9	● 101267		● 196056	
3/8	24	9.52	100	14	39	10	8	3	8.5	● 101266		● 196057	
7/16	20	11.11	100	14		8	6.2	3	9.8		● 101334		● 196058
1/2	20	12.7	100	14		9	7	4	11.4		● 101331		● 196059
5/8	18	15.87	100	14		12	9	4	14.5		● 101333		● 174297
3/4	16	19.05	125	18		14	11	4	17.5		● 101332		● 158882

UNF ASME B1.1

PM

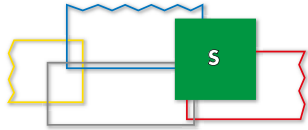
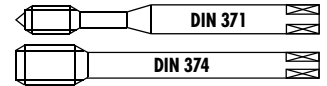

S320VS-4		VS	13 15 16 22 23 24 52
S420VS-4		VS	13 15 16 22 23 24 52
S360VS-3		VS	13 15 16 22 23 24 52
S460VS-3		VS	13 15 16 22 23 24 52

S320VS-4	S420VS-4	S360VS-3	S460VS-3

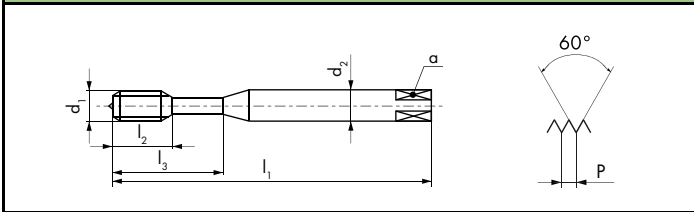

3B UNF(J)	3B UNF(J)		

\emptyset " d ₁ UNF	P TPI	d ₁ mm	l ₁ mm	l ₂ mm	l ₃ mm	d ₂ mm	a mm			ID	ID
10	32	4.82	70	15	25	6	4.9	3	4.15	● 111814	
1/4	28	6.35	80	17	30	7	5.5	3	5.55	● 111813	
5/16	24	7.93	90	20	35	8	6.2	3	7	● 111816	
3/8	24	9.52	100	22	39	10	8	3	8.6	● 111818	
7/16	20	11.11	100	22		8	6.2	3	10		● 111837

\emptyset " d ₁ UNF	P TPI	d ₁ mm	l ₁ mm	l ₂ mm	l ₃ mm	d ₂ mm	a mm			ID	ID
10	32	4.82	70	9	25	6	4.9	3	4.15		● 111815
1/4	28	6.35	80	11	30	7	5.5	3	5.55		● 111820
5/16	24	7.93	90	12.5	35	8	6.2	3	7		● 111817
3/8	24	9.52	100	14	39	10	8	3	8.6		● 111819
7/16	20	11.11	100	14		8	6.2	3	10		● 111833



S | RESPECTING THREADING



aero

SA320-4



15 16 52 64

SA350-3



15 16 52 64

TL351VS-3



41 42

SA320-4

SA350-3

TL351VS-3

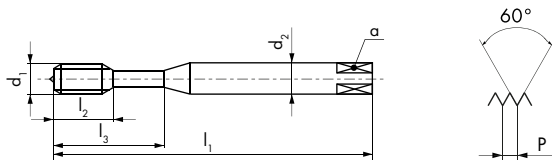

2B

2B

2B

Ø" d ₁ UNF	P TPI	d ₁ mm	l ₁ mm	l ₂ mm	l ₃ mm	d ₂ mm	a mm		
10	32	4.82	70	15		6	4.9	3	4.05
1/4	28	6.35	80	15	23	7	5.5	3	5.5
5/16	24	7.93	90	18	29	8	6.2	3	6.9
3/8	24	9.52	100	20	33	10	8	3	8.5

ID

ID

ID

● 149133	● 149135	● 152047
● 149230	● 149232	● 152066
● 149277	● 149279	● 152072
● 149339	● 149341	● 152083

3B
UNF(J)

3B
UNF(J)

3B
UNF(J)

Ø" d ₁ UNF	P TPI	d ₁ mm	l ₁ mm	l ₂ mm	l ₃ mm	d ₂ mm	a mm		
4	48	2.84	56	12		3.5	2.7	3	2.35
10	32	4.82	70	15		6	4.9	3	4.15
1/4	28	6.35	80	15	23	7	5.5	3	5.55
5/16	24	7.93	90	18	29	8	6.2	3	7
3/8	24	9.52	100	20	33	10	8	3	8.6

ID

ID

ID

	● 149015	
● 146098	● 149138	● 148004
● 146404	● 149235	● 148012
● 146393	● 149282	● 148016
● 147165	● 149344	● 148023

UNF ASME B1.1

PM

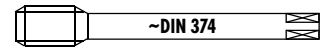

aero

SA420-4



15 16 52 64

SA450-3



15 16 52 64

TL451VS-3



41 42

SA420-4

SA450-3

TL451VS-3

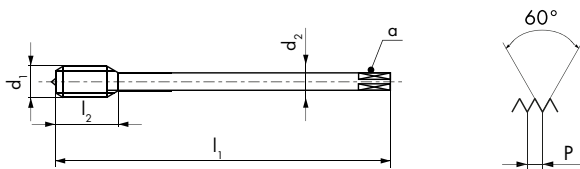

$\emptyset'' d_1$ UNF	P TPI	d_1 mm	l_1 mm	l_2 mm	d_2 mm	a mm		
7/16	20	11.11	100	22	8	6.2	* 4	9.8
1/2	20	12.7	100	24	9	7	4	11.4
5/8	18	15.87	100	26	12	9	4	14.5

ID	ID	ID
● 152286	● 152290	
● 152287	● 152291	
★ 152289		

$\emptyset'' d_1$ UNF	P TPI	d_1 mm	l_1 mm	l_2 mm	d_2 mm	a mm		
7/16	20	11.11	100	22	8	6.2	* 4	10
1/2	20	12.7	100	24	9	7	4	11.55
9/16	18	14.28	100	24	11	9	4	13.05
5/8	18	15.87	100	26	12	9	4	14.6

ID	ID	ID
● 147187	● 152302	● 148031
● 147189	● 152303	● 152310
● 146395		
● 147169		

* SA420-4= 3

aero

SA390-3



16 53

SA390-3

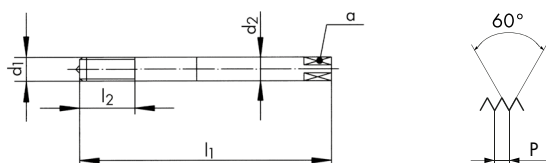

$\emptyset'' d_1$ UNF	P TPI	d_1 mm	l_1 mm	l_2 mm	d_2 mm	a mm			ID
10	32	4.82	70	15	6	4.9	3	4.15	● 149687
1/4	28	6.35	80	20	7	5.5	3	5.55	● 149715
5/16	24	7.93	90	25	8	6.2	3	7	● 149728
3/8	24	9.52	100	30	10	8	3	8.6	● 149745



NEW

СОВЕРШЕННЫЙ "УНИВЕРСАЛ"

Доступен для резьб M, MF, UNC, UNF и G

THE PERFECT "ALLROUNDER"

Available for M, MF, UNC, UNF and G threads





PM

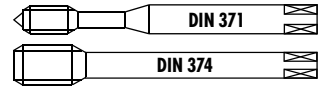

QTAP

Q320VS-4



Q420VS-4



Q323VS-4



Q423VS-4



- 11 12 13 14
- 15 21 22 23
- 24 31 32 51
- 52 61 62 63
- 64 71 72 73
- 74 81 82 83
- 91 92 94

Q320VS-4

Q420VS-4

Q323VS-4

Q423VS-4



NEW



NEW



NEW



NEW

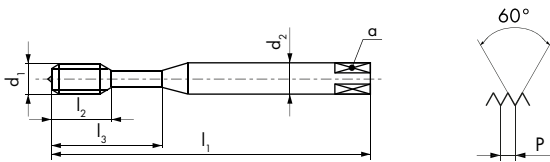

2B



2B



2B



2B

Ø" d ₁ UNF	P TPI	d ₁ mm	l ₁ mm	l ₂ mm	l ₃ mm	d ₂ mm	a mm		
10	32	4.82	70	15	25	6	4.9	3	4.05
1/4	28	6.35	80	17	30	7	5.5	3	5.5
5/16	24	7.93	90	20	35	8	6.2	3	6.9
3/8	24	9.52	100	22	39	10	8	3	8.5
7/16	20	11.11	100	19		8	6.2	3	9.8
1/2	20	12.7	100	24		9	7	3	11.4

ID

ID

ID

ID

● 196298

● 197631

1/4 28 6.35 80 17 30 7 5.5 3 5.5

● 196299

● 197632

5/16 24 7.93 90 20 35 8 6.2 3 6.9

● 196300

● 197633

3/8 24 9.52 100 22 39 10 8 3 8.5

● 196301

● 197634

7/16 20 11.11 100 19 8 6.2 3 9.8

● 196302

● 197635

1/2 20 12.7 100 24 9 7 3 11.4

● 196303

● 197636



≤ Ø 16 > Ø 16

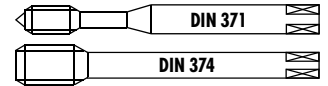
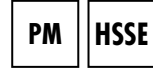

QTAP

Q360VS-3



Q460VS-3



Q363VS-3



Q463VS-3

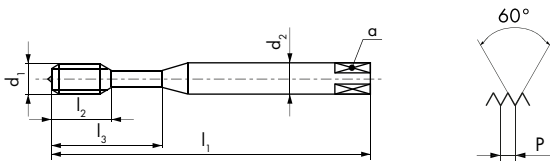

Q360VS-3

Q460VS-3

Q363VS-3

Q463VS-3



NEW



NEW



NEW



NEW





2B

2B

2B

2B

Ø" d ₁ UNF	P TPI	d ₁ mm	l ₁ mm	l ₂ mm	l ₃ mm	d ₂ mm	a mm		
10	32	4.82	70	9	25	6	4.9	3	4.05
1/4	28	6.35	80	11	30	7	5.5	3	5.5
5/16	24	7.93	90	12.5	35	8	6.2	3	6.9
3/8	24	9.52	100	14	39	10	8	3	8.5
7/16	20	11.11	100	14		8	6.2	3	9.8
1/2	20	12.7	100	14		9	7	3	11.4
5/8	18	15.87	100	14		12	9	3	14.5
3/4	16	19.05	125	18		14	11	4	17.5

ID

ID

ID

ID

● 196304

● 197637

● 196305

● 197638

● 196306

● 197639

● 196307

● 197640

● 196308

● 197641

● 196309

● 197642

● 196310

● 197643

● 196311

● 197644

UNF ASME B1.1



Uniquement pour taraudage synchrone
Nur für Synchrobearbeitung
Only for rigid tapping
Solo per maschiatura sincrona
Solo para rosado sincronizado
Тільки для рiгiд tapping

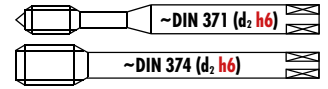

RTS Rigid Tapping Synchro

RTS320VS-4



RTS420VS-4



RTS362VS-3

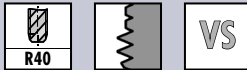

RTS462VS-3

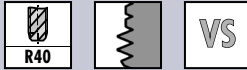

RTS320VS-4

RTS420VS-4

RTS362VS-3

RTS462VS-3

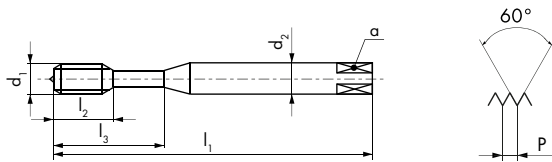

Ø" d ₁ UNF	P TPI	d ₁ mm	l ₁ mm	l ₂ mm	l ₃ mm	d ₂ h6 mm	a mm		
10	32	4.82	70	9	25	6	4.9	3	4.05
1/4	28	6.35	80	11	30	* 6	* 4.9	3	5.5
5/16	24	7.93	90	12.5	35	8	6.2	3	6.9
3/8	24	9.52	100	14	39	10	8	3	8.5
1/2	20	12.7	110	14		* 10	* 8	3	11.4

ID	ID	ID	ID
● 157409		● 157413	
● 157410		● 157414	
● 157411		● 157415	
● 157412		● 157416	
	● 157417		● 157418

* Norme DC / * DC Norm/ * Norma DC



sur demande
auf Anfrage
on request
su richiesta
sobre pedido
но запит

A large, dark metal drill bit is the central focus of the image, standing vertically in a field of sunflowers. The background features a vibrant sunset sky with orange and blue clouds. The sunflowers are in full bloom, with bright yellow petals and dark brown centers. The drill bit has a yellow band near its base.

W | IMPROVING THREADING



UNF ASME B1.1

≤ Ø 2.8 > Ø 2.8

PM HSS

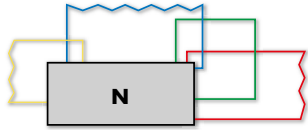
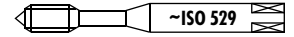

N1110-1			
N1110-3			31 62 73 74 91
N1110-S			

N1110-1	N1110-3	N1110-S	

--	--	--

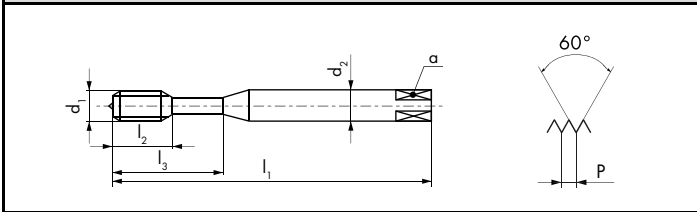

	2B	2B

Ø" d ₁ UNF	P TPI	d ₁ mm	l ₁ mm	l ₂ mm	l ₃ mm	d ₂ mm	a mm			ID	ID	ID
0	80	1.52	40	7		2.5	2.1	3	1.2	● 102811	● 103010	● 111079
1	72	1.85	40	8		2.5	2.1	3	1.5	● 102812	● 103011	● 111080
8	36	4.16	53	13	21	4.5	3.55	3	3.5		★ 103022	
10	32	4.82	58	16	25	5	4	3	4.05	● 102814	● 103013	● 111082
12	28	5.48	62	17	26	5.6	4.5	3	4.6		★ 103014	
1/4	28	6.35	66	19	30	6.3	5	3	5.5	● 102813	● 103012	● 111081
5/16	24	7.93	72	22	35	8	6.3	3	6.9	● 102821	● 103020	● 111089
3/8	24	9.52	80	24	39	10	8	3	8.5	● 102818	● 103017	● 111086

UNF ASME B1.1

HSS

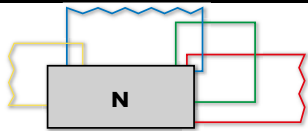
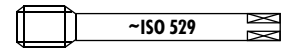

	N1210-1	N1210-3	N1210-S	
N1210-1				
N1210-3				
N1210-S				

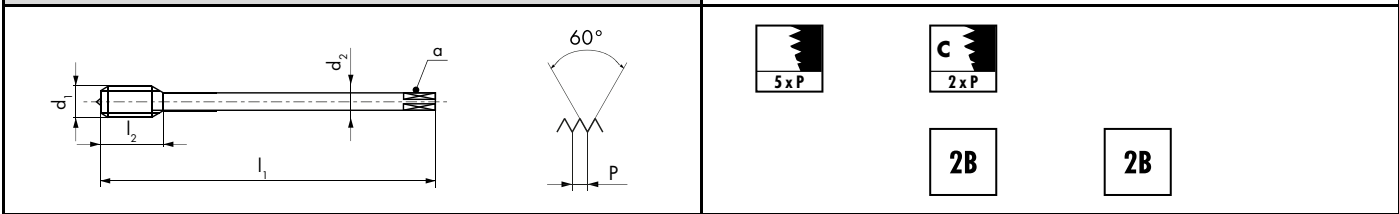
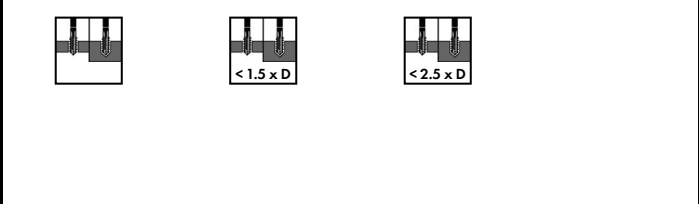

$\emptyset'' d_1$ UNF	P TPI	d_1 mm	l_1 mm	l_2 mm	d_2 mm	a mm			ID	ID	ID
7/16	20	11.11	85	22	8	6.3	3	9.8	● 103411	● 103626	● 111255
1/2	20	12.7	89	24	9	7.1	3	11.4	● 103407	● 103622	● 111251
5/8	18	15.87	102	32	12.5	10	3	14.5	● 103410	● 103625	● 111254
3/4	16	19.05	112	33	14	11.2	4	17.5	● 103409	● 103624	● 111253
7/8	14	22.22	115	32	16	12.5	4	20.4	● 103412	● 103627	● 111256
1	12	25.4	130	45	18	14	4	23.3	● 103408	● 103623	● 111252

UNEF ASME B1.1

HSS

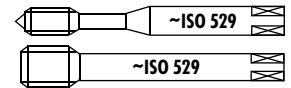

										N1110-3	N1120-4	N1210-3	N1220-4				
N1110-3		31	62	73	74	91											
N1120-4		62	63	64	72	73	74										
N1210-3		31	62	73	74	91											
N1220-4		62	63	64	72	73	74										
\emptyset " d ₁ UNEF	P TPI	d ₁ mm	l ₁ mm	l ₂ mm	l ₃ mm	d ₂ mm	a mm			ID	ID	ID	ID				
12	32	5.48	62	17	26	5.6	4.5	3	4.7	● 103007	● 103118						
1/4	32	6.35	66	19	30	6.3	5	3	5.6	● 103006	● 103117						
5/16	32	7.93	72	22	35	8	6.3	3	7.2	● 103009	● 103120						
3/8	32	9.52	80	24	39	10	8	3	8.75	● 103008	● 103119						
7/16	28	11.11	85	22		8	6.3	3	10.25			● 103615	● 103754				
1/2	28	12.7	89	24		9	7.1	3	11.85			● 103609	● 103749				
9/16	24	14.28	95	24		11.2	9	3	13.2			● 103617	● 103756				
5/8	24	15.87	102	32		12.5	10	3	14.8			● 103614	● 103753				
11/16	24	17.46	104	26		14	11.2	4	16.4			● 103611					
3/4	20	19.05	112	33		14	11.2	4	17.8			● 103613					
7/8	20	22.22	115	32		16	12.5	4	21			● 103616					
1	20	25.4	120	30		18	14	4	24.1			● 103610					

UNS, UN ASME B1.1

HSSE



										N410-3	N460-3	N460V-3		
N410-3 31 62 73 74 91														
N460-3 63 72 73 74 81 91														
N460V-3 V 11 12 32														
										2B	2B	2B		
\emptyset " d ₁ UNS	P TPI	d ₁ mm	l ₁ mm	l ₂ mm	d ₂ mm	a mm				ID	ID	ID		
1/4	36	6.35	80	17	4.5	3.4	3	5.65	●	104899				
1/2	24	12.7	100	24	9	7	3	11.6	●	104900				
1	14	25.4	140	34	18	14.5	4	23.6	●	104898				
1	14	25.4	140	22	18	14.5	4	23.6			●	102437	●	142789
\emptyset " d ₁ UN	P TPI	d ₁ mm	l ₁ mm	l ₂ mm	d ₂ mm	a mm				ID	ID			
1 1/8	8	28.57	180	30	22	18	4	25.5		●	102415	●	142790	
1 1/4	8	31.75	180	30	22	18	4	28.7		●	102414	●	142520	
1 3/8	8	34.92	200	36	28	22	5	31.8		●	104896	●	142792	
1 1/2	8	38.1	200	40	32	24	5	35		●	102413	●	142793	
1 3/4	8	44.45	220	44	36	29	5	41.4				●	115198	
2	8	50.8	250	38	40	32	5	47.7				●	111622	











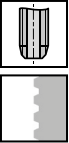
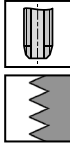
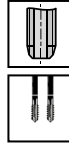
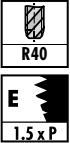

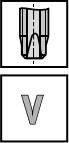

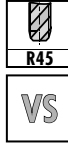







G Указатель — Машинные метчики G (BSP) DIN EN ISO 228

Directory — Machine taps G (BSP) DIN EN ISO 228

	N						
Характеристики Characteristics		 V	 TiN	 R40	 R40 V	 R40 TiN	 R40 TiN V
Тип отверстия Hole type							
	N410-3	N420-4 N420V-4	N420TN-4	N460-3	N460V-3	N460TN-3	N462V-3
Длинный по DIN DIN long	DIN 5156						
	204	205	205	206	206	206	206
Длинный по DIN DIN long	~ DIN 376						
Короткий по DIN DIN short	DIN 5157						
Левый LH LH Left-hand thread	DIN 5156						
	204						





























G









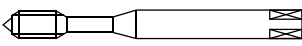
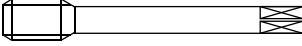











Указатель — Машинные и ручные метчики G (BSP) DIN EN ISO 228 Directory — Machine and hand taps G (BSP) DIN EN ISO 228

N			W		Z			
			 R40 E 1.5xP	 R40 E 1.5xP DLC	 V	 VS	 R40 V	 R45 VS
								
								
N210-1	N210-3	N210-S	W460-5	W460DL-5	Z420V-4	Z420VS-4	Z460V-3	Z470VS-3
			207	207	208	208	208	
								209
213	213	213						

G Указатель — Машинные метчики G (BSP) DIN EN ISO 228

Directory — Machine taps G (BSP) DIN EN ISO 228

	H	GG	QTAP		RTS	
Характеристики Characteristics	 R25	 R15  NV	 VS	 R40  VS	 R40  VS	 R40  E 1.5xP  VS
			 	 		
			 	 		
Тип отверстия Hole type						
						
	H450-3	GG450NV-3	Q420VS-4 Q423VS-4	Q460VS-3 Q463VS-3	RTS462VS-3	RTS462VS-5
Длинный по DIN DIN long	DIN 5156					
	207	207	210	211		
Длинный по DIN DIN long	~ DIN 376					
					212	212
Короткий по DIN DIN short	DIN 5157					
Левый LH LH Left-hand thread	DIN 5156					

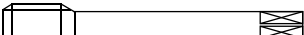
	N					
Характеристики Characteristics		 		 		HSS  
						
Тип отверстия Hole type						
				N1110-3	N1120-4	
Короткий по ISO ISO short	ISO 529			216 - 217	216	
W	ISO 529			216 - 217	216	
SV	ISO 529			217		
	N420-3	N410-3	D5800	N1210-3	N1220-4	N5120
Длинный по DIN DIN long	DIN 5156	214				
Длинный по DIN DIN long	DC	214	215			
Короткий по ISO ISO short	ISO 529			216 - 217	216	
Rp	DIN 5156	214				
Rc	DC	214	215			
W	ISO 529			216	216	
SV	ISO 529 / DC			217		217

										N410-3	N410-3 LH		
<p>N410-3 31 62 73 74 91</p> <p>N410-3 LH LH 31 62 73 74 91</p>													
$\frac{\text{Ø}''}{G}$	d_1	P	d_1	l_1	l_2	d_2	a			ID	ID		
1/8	28	9.72	90	22	7	5.5	3	8.75	●	101855			
1/4	19	13.15	100	20	11	9	3	11.6	●	101853	● 101854		
3/8	19	16.66	100	20	12	9	4	15.2	●	101861	● 101862		
1/2	14	20.95	125	22	16	12	4	18.9	●	101851	● 101852		
3/4	14	26.44	140	28	20	16	4	24.4	●	101859			
1	11	33.24	160	32	25	20	4	30.7	●	101857			
1 1/4	11	41.91	170	32	32	24	5	39.3	●	101850			
1 1/2	11	47.8	190	32	36	29	5	45.2	●	101849			

G DIN EN ISO 228 (BSP)

HSSE



										N420-4	N420V-4	N420TN-4
N420-4												
N420V-4												
N420TN-4												
$\frac{\text{Ø}''}{G}$ d ₁	P TPI	d ₁ mm	l ₁ mm	l ₂ mm	d ₂ mm	a mm				ID	ID	ID
1/16	28	7.72	90	18	6	4.9	3	6.75		● 102045		
1/8	28	9.72	90	22	7	5.5	3	8.75		● 102048	● 102258	● 102236
1/4	19	13.15	100	20	11	9	3	11.6		● 102047	● 102257	● 102235
3/8	19	16.66	100	20	12	9	3	15.2		● 102053	● 102261	● 102238
1/2	14	20.95	125	22	16	12	4	18.9		● 102046	● 102256	● 102234
5/8	14	22.91	125	25	18	14.5	4	20.9		● 102054	● 144722	
3/4	14	26.44	140	28	20	16	4	24.4		● 102052	● 102260	● 102237
1	11	33.24	160	32	25	20	4	30.7		● 102049	● 102259	
1 1/4	11	41.91	170	32	32	24	5	39.3		● 102043		
1 1/2	11	47.8	190	32	36	29	5	45.2		● 102042		
2	11	59.61	220	36	45	35	5	57		● 102051		
2 1/2	11	75.18	280	36	50	39	6	72.6		● 102050		

G DIN EN ISO 228 (BSP)

HSSE



										N460-3	N460V-3	N460TN-3	N462V-3			
<p>N460-3 63 72 73 74 81 91</p> <p>N460V-3 11 12 32</p> <p>N460TN-3 11 12 13 14 32</p> <p>N462V-3 11 12 32</p>																
										< 2.5 x D	< 2.5 x D	< 2.5 x D	< 2.5 x D			
										2.5 x P	2.5 x P	2.5 x P	2.5 x P			
$\frac{\text{Ø}''}{G}$ d_1	P TPI	d_1 mm	l_1 mm	l_2 mm	d_2 mm	a mm				ID	ID	ID	ID			
1/16	28	7.72	90	12.5	6	4.9	3	6.75	●	102341						
1/8	28	9.72	90	14	7	5.5	3	8.75	●	102344	●	102457	●	143687		
1/4	19	13.15	100	14	11	9	3	11.6	●	102343	●	102456	●	102443	●	143600
3/8	19	16.66	100	14	12	9	4	15.2	●	102348	●	102460	●	102446	●	143431
1/2	14	20.95	125	20	16	12	4	18.9	●	102342	●	102455	●	102442	●	143921
5/8	14	22.91	125	20	18	14.5	4	20.9	●	102349	●	143711				
3/4	14	26.44	140	22	20	16	4	24.4	●	102347	●	102459	●	102445	●	143688
1	11	33.24	160	26	25	20	4	30.7	●	102345	●	102458				
1 1/4	11	41.91	170	30	32	24	5	39.3	●	102340	●	111608				
1 1/2	11	47.8	190	35	36	29	5	45.2	●	102339	●	111609				
2	11	59.61	220	41	45	35	6	57	●	102346	●	111503				

G DIN EN ISO 228 (BSP)

≤ Ø 25.4 > Ø 25.4

HSSE
W

PM
H/GG

HSSE
H/GG



W460-5 **W460DL-5** **H450-3** **GG450NV-3**

W460-5 **71 72 81**

W460DL-5 **71 72 73**



H450-3 **15 16 62 64 82**

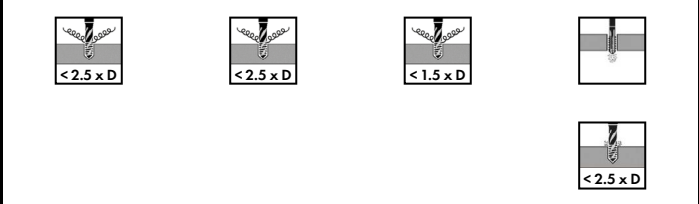

GG450NV-3 **31**

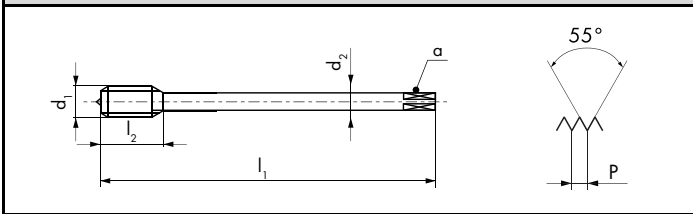

E 1.5 x P **E** 1.5 x P **C** 2.5 x P **C** 2.5 x P

Ø" d ₁ G	P TPI	d ₁ mm	l ₁ mm	l ₂ mm	d ₂ mm	a mm		
1/8	28	9.72	90	14	7	5.5	3	8.75
1/4	19	13.15	100	14	11	9	* 4	11.6
3/8	19	16.66	100	14	12	9	4	15.2
1/2	14	20.95	125	20	16	12	4	18.9
3/4	14	26.44	140	22	20	16	4	24.4
1	11	33.24	160	26	25	20	4	30.7

* W460-5 = 3
* W460DL-5 = 3

ID	ID	ID
● 119350	● 176728	● 101298
● 119300	● 176729	● 101297
● 119682	● 176730	● 101301
● 119199	● 176731	● 101296
		● 101300
		● 101299

Ø" d ₁ G	P TPI	d ₁ mm	l ₁ mm	l ₂ mm	d ₂ mm	a mm		
1/8	28	9.72	90	22	7	5.5	4	8.75
1/4	19	13.15	100	20	11	9	4	11.6
3/8	19	16.66	100	20	12	9	4	15.2
1/2	14	20.95	125	22	16	12	4	18.9
3/4	14	26.44	140	28	20	16	4	24.4
1	11	33.24	160	32	25	20	4	30.7

ID
● 102309
● 102308
● 102312
● 102307
● 102311
● 102310

G DIN EN ISO 228 (BSP)

< Ø 25.4 > Ø 25.4

PM Z420	HSSE Z420	HSSE Z460
-------------------	---------------------	---------------------



										Z420V-4	Z420VS-4	Z460V-3
Z420V-4 V												
Z420VS-4 VS												
Z460V-3 V												
Ø" d ₁ G	P TPI	d ₁ mm	l ₁ mm	l ₂ mm	d ₂ mm	a mm				ID	ID	
1/8	28	9.72	90	22	7	5.5	3	8.75	●	142794	●	142800
1/4	19	13.15	100	20	11	9	3	11.6	●	142795	●	119303
3/8	19	16.66	100	20	12	9	3	15.2	●	142796	●	142802
1/2	14	20.95	125	22	16	12	4	18.9	●	142797	●	142803
3/4	14	26.44	140	28	20	16	4	24.4	●	142798		
1	11	33.24	160	32	25	20	4	30.7	●	142799		
Ø" d ₁ G	P TPI	d ₁ mm	l ₁ mm	l ₂ mm	d ₂ mm	a mm				ID		
1/8	28	9.72	90	14	7	5.5	3	8.75		● 104726		
1/4	19	13.15	100	14	11	9	3	11.6		● 104725		
3/8	19	16.66	100	14	12	9	4	15.2		● 104728		
1/2	14	20.95	125	20	16	12	4	18.9		● 104724		
3/4	14	26.44	140	22	20	16	4	24.4		● 104727		
1	11	33.24	160	26	25	20	4	30.7		● 105142		

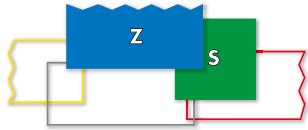

Z470VS-3

Z470VS-3



VS



Z470VS-3



VS

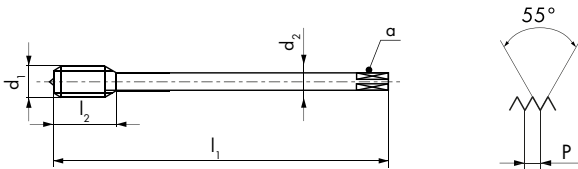

$\frac{\text{Ø}''}{G}$ d ₁	P TPI	d ₁ mm	l ₁ mm	l ₂ mm	d ₂ h6 mm	a mm			ID
1/8	28	9.72	100	14	* 8	* 6.2	3	8.75	● 165198
1/4	19	13.15	110	14	* 12	* 9	4	11.6	● 165199
3/8	19	16.66	110	18	12	9	4	15.2	● 165200
1/2	14	20.95	125	20	16	12	4	18.9	● 165201

* Norme DC / * DC Norm/ * Norma DC



QTAP

Q420VS-4



VS

Q423VS-4

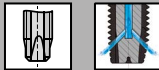

VS

- 11
- 12
- 13
- 14
- 15
- 21
- 22
- 23
- 24
- 31
- 32
- 51
- 52
- 61
- 62
- 63
- 64
- 71
- 72
- 73
- 74
- 81
- 82
- 83
- 91
- 92
- 94

Q420VS-4

Q423VS-4



NEW



NEW

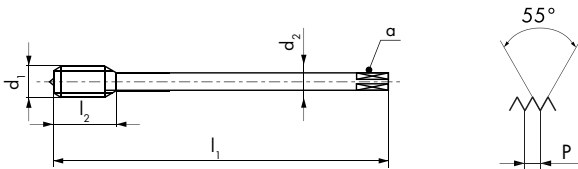

Ø" d ₁ G	P TPI	d ₁ mm	l ₁ mm	l ₂ mm	d ₂ mm	a mm		
1/8	28	9.72	90	22	7	5.5	3	8.75
1/4	19	13.15	100	20	11	9	3	11.6
3/8	19	16.66	100	20	12	9	3	15.2
1/2	14	20.95	125	22	16	12	4	18.9

ID

ID

● 196312

● 197645

● 196313

● 197646

● 196314

● 197647

● 196315

● 197648

G

DIN EN ISO 228 (BSP)



≤ Ø 16 > Ø 16

PM HSSE



QTAP

Q460VS-3



Q463VS-3



- 11 12 13 14
- 15 21 22 23
- 24 31 32 51
- 52 61 62 63
- 64 71 72 73
- 74 81 82 83
- 91 92 94

Q460VS-3

Q463VS-3



NEW



NEW

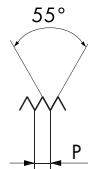
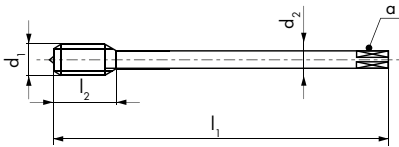

Ø" d ₁ G	P TPI	d ₁ mm	l ₁ mm	l ₂ mm	d ₂ mm	a mm		
1/8	28	9.72	90	14	7	5.5	3	8.75
1/4	19	13.15	100	14	11	9	3	11.6
3/8	19	16.66	100	14	12	9	4	15.2
1/2	14	20.95	125	20	16	12	4	18.9

ID

ID

● 196316

● 197649

● 196317

● 197650

● 196318

● 197651

● 196319

● 197652

G

DIN EN ISO 228 (BSP)



Uniquement pour taraudage synchrone
Nur für Synchrobearbeitung
Only for rigid tapping
Solo per maschiatura sincrona
Solo para roscado sincronizado
Тільки для рiгiд tapping

PM



RTS

Rigid Tapping Synchro

RTS462VS-3



RTS462VS-5

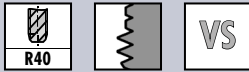

RTS462VS-3

RTS462VS-5

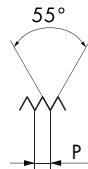
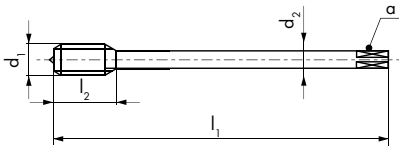

$\frac{\text{Ø}''}{G}$ d_1	P TPI	d_1 mm	l_1 mm	l_2 mm	d_2 h6 mm	a mm		
1/8	28	9.72	100	14	* 8	* 6.2	3	8.75
1/4	19	13.15	110	14	* 12	* 9	3	11.6
3/8	19	16.66	110	18	12	9	4	15.2
1/2	14	20.95	125	20	16	12	4	18.9

ID	ID
● 151861	● 170629
● 151868	● 170631
● 151872	● 170633
● 150685	● 170635







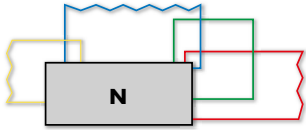

* Norme DC / * DC Norm/ * Norma DC

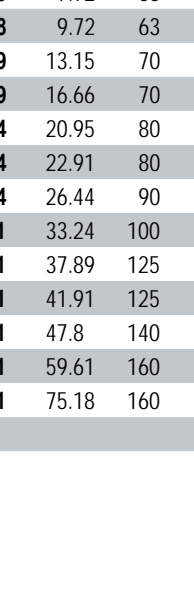

sur demande
auf Anfrage
on request
su richiesta
sobro pedido
но зaпpoc

≥ Ø 6 mm



										N210-1	N210-3	N210-S	
<p>N210-1</p> 													
<p>N210-3</p>  													
<p>N210-S</p> 													
													
													
$\frac{\text{Ø}''}{G}$	P TPI	d_1 mm	l_1 mm	l_2 mm	d_2 mm	a mm				ID	ID	ID	
1/16	28	7.72	63	18	6	4.9	3	6.75			● 101418		
1/8	28	9.72	63	22	7	5.5	3	8.75	● 101404	● 101421	● 119386		
1/4	19	13.15	70	20	11	9	3	11.6	● 101403	● 101420	● 119336		
3/8	19	16.66	70	20	12	9	4	15.2	● 101409	● 101427	● 110938		
1/2	14	20.95	80	22	16	12	4	18.9	● 101402	● 101419	● 119264		
5/8	14	22.91	80	25	18	14.5	4	20.9	● 101411	● 105140	● 110940		
3/4	14	26.44	90	28	20	16	4	24.4	● 101408	● 101426	● 110937		
1	11	33.24	100	32	25	20	4	30.7	● 101405	● 101422	● 110933		
1 1/8	11	37.89	125	32	28	22	4	35.3		● 101415			
1 1/4	11	41.91	125	32	32	24	5	39.3	● 101400	● 101414	● 111425		
1 1/2	11	47.8	140	32	36	29	5	45.2	● 101399	● 101413	● 110934		
2	11	59.61	160	36	45	35	5	57	● 101407	● 101425	● 110935		
2 1/2	11	75.18	160	36	50	39	6	72.6		● 101423			

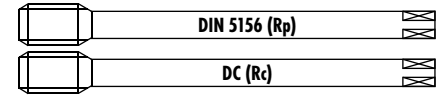

Rp, Rc DIN EN 10226

HSSE

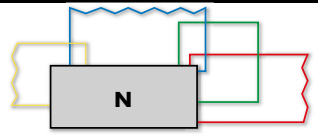
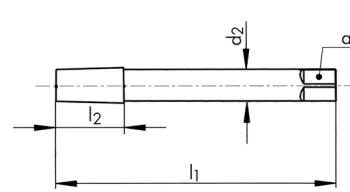

		N420-3			N410-3				
N420-3									
N410-3									
$\emptyset'' d_1$ Rp	P TPI	d_1 mm	l_1 mm	l_2 mm	d_2 mm	a mm			ID
1/8	28	9.72	90	22	7	5.5	3	8.6	● 104911
1/4	19	13.15	100	20	11	9	3	11.5	● 104912
3/8	19	16.66	100	20	12	9	3	15	● 104913
1/2	14	20.95	125	22	16	12	4	18.5	● 104914
3/4	14	26.44	140	28	20	16	4	24	● 104915
1	11	33.24	160	32	25	20	4	30.25	● 104916
$\emptyset'' d_1$ Rc	P TPI	d_1 mm	l_1 mm	l_2 mm	d_2 mm	a mm			ID
1/8	28	9.72	71	13	8	6.2	5		● 104917
1/4	19	13.15	80	20	11	9	5		● 104918
3/8	19	16.66	90	20	12	9	5		● 104919
1/2	14	20.95	100	26	16	12	5		● 104920
3/4	14	26.44	110	26	20	16	5		● 104921
1	11	33.24	125	32	25	20	5		● 104922

Vc (m/min) $\emptyset d_1$ - Guide Line				
Rc	1/16" - 1/4"	3/8" - 1/2"	3/4" - 1"	1.1/4" - 2"
	10	8	7	5
	18	15	13	10

					D5800			
								
								
Ø" Rc	l₁ mm	l₂ mm	d₂ mm	a mm	ID			
1/16	70	17	6	4.9	● 118701			
1/8	70	17	8	6.2	● 110531			
1/4	80	27	10	8	● 110530			
3/8	85	27	12	9	● 110535			
1/2	95	35	16	12	● 110529			
3/4	105	35	20	16	● 110534			
1	130	43	25	20	● 110532			

Диаметр отверстия под коническую трубную резьбу по DIN EN 10226 Core hole diameters for tapered pipe thread to DIN EN 10226

Отверстие с параллельными стенкам
Повышенный износ, не рекомендуется

Parallel hole
Increased tap wear, not recommended

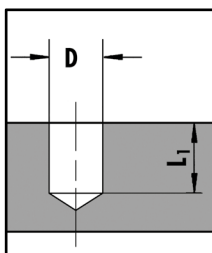

Коническое отверстие 1:16
Предварительное отв. D₂ и развертывание до D₃

Tapered hole 1:16
Pre-drill at Ø D₂ and taper-ream to Ø D₃

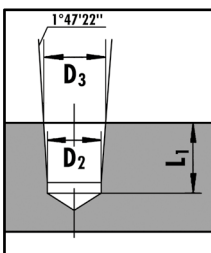

Коническое отверстие
Заход метчика на глубину L₂=номинальный диаметр

Tapped hole
Engage tap to hole depth L₂ = nominal Ø

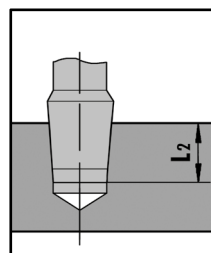

Ø" Rc	l₁ min. mm	D₁ mm	D₂ mm	D₃ mm	l₂ mm
1/16	11.9	6.2	6.1	6.56	10.6
1/8	11.9	8.2	8.1	8.57	10.6
1/4	17.7	11	10.75	11.45	15.7
3/8	18.1	14.5	14.25	14.95	16.1
1/2	24	18	17.75	18.63	21.4
3/4	25.3	23.5	23	24.12	21.5
1	30.6	29.5	29	30.29	26.3

W BS 84 (BSW)

HSS

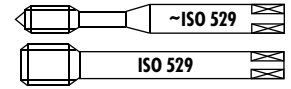













										N1110-3	N1210-3	N1120-4	N1220-4
N1110-3													
N1210-3													
N1120-4													
N1220-4													
\emptyset " W	d ₁ TPI	d ₁ mm	l ₁ mm	l ₂ mm	l ₃ mm	d ₂ mm	a mm			ID	ID	ID	ID
1/8	40	3.17	48	11	18	3.15	2.5	3	2.5	● 103025		● 103126	
5/32	32	3.96	53	13	21	4	3.15	3	3.1	● 103031		● 103130	
3/16	24	4.76	58	16	25	5	4	3	3.6	● 103026		● 103127	
1/4	20	6.35	66	19	30	6.3	5	3	4.9	● 103024		● 103125	
5/16	18	7.93	72	22	35	8	6.3	3	6.4	● 103030		● 103129	
3/8	16	9.52	80	24	39	10	8	3	7.7	● 103028		● 103128	
7/16	14	11.11	85	22		8	6.3	3	9.1		● 103642		● 103771
1/2	12	12.7	89	24		9	7.1	3	10.3		● 103634		● 103767
5/8	11	15.87	102	32		12.5	10	3	13.3		● 103641		● 103770
3/4	10	19.05	112	33		14	11.2	3	16.2		● 103640		● 103769

										N1110-3	N1210-3	N5120		
N1110-3														
N1210-3														
N5120														
$\emptyset d_1$	P	l_1	l_2	l_3	d_2	a					ID			
W	TPI/mm	mm	mm	mm	mm	mm					● 103029			
5	36/TPI/1"	B6	58	16	25	5	4	3	4.3*		● 111143			
6.82	0.625	B8	66	19	30	7.1	5.6	3	6.2*					
$\emptyset d_1$	P	l_1	l_2	l_3	d_2	a					ID		ID	
SV	mm	mm	mm	mm	mm	mm					● 130429			
10	0.833	W10	80	24	39	10	8	3	* 8.9				● 103591	
12	1.25	W12	89	24		9	7.1	3	* 10.5				● 103592	
15	1.25	W15	90	23		11.2	9	3	* 13.5				● 103593	
20	1.666	W20	112	37		14	11.2	4	* 17.9				● 103594	
25	1.693	W25	120	30		18	14	4	* 22.75					
* Tol. $\begin{matrix} \emptyset .1 \text{ mm} \\ 0 \end{matrix}$														
$\emptyset d_1$	P	d_2	l_1							ID				
W	mm	mm	mm							● 130215				
6.82	0.625	B6	25	9	4	6.75								

NPT, NPTF

Указатель — Машинные метчики, NPT ASME B1.20.1 и NPTF ANSI B1.20.3
 Directory — Machine taps, NPT ASME B1.20.1 and NPTF ANSI B1.20.3

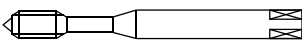
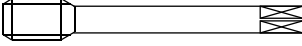
N				
Характеристики Characteristics		 	 	 1:16
				
Тип отверстия Hole type				
				
	N410-3	N410V-3	N411V-3	D5800
NPT Длинный по DIN NPT DIN long DC	220	220	220	221
NPTF Длинный по DIN NPTF DIN long DC	220			

PG, TR

Указатель — Машинные и ручные метчики, PG DIN 40430, TR ISO 2901-2904, DIN 103
 Directory — Machine and hand taps, PG DIN 40430, TR ISO 2901-2904, DIN 103

	N					
Характеристики Characteristics						
Тип отверстия Hole type						
	N420-3	N410-1	N410-2	N410-3	N410-5	N410-8
PG Длинный по DIN PG DIN long DIN 40433	222					
TR Длинный по DIN TR DIN long DC		223	223	223	223	222
Класс точности Tolerance TR 7H				223	223	222

NPT, NPTF

ASME B1.20.1, ANSI B1.20.3

HSSE

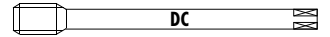

							N410-3	N410V-3	N411V-3	N410-3
N410-3										
N410V-3										
N411V-3										
N410-3										
$\emptyset'' d_1$ NPT, NPTF	P TPI	l_1 mm	l_2 mm	d_2 mm	a mm		ID	ID	ID	ID
1/16	27	71	13	7	5.5		● 101961	● 102021	● 102031	● 101971
1/8	27	71	13	8	6.2		● 101964	● 102024	● 102034	● 101974
1/4	18	80	20	11	9		● 101963	● 102023	● 102033	● 101973
3/8	18	90	20	12	9		● 101968	● 102028	● 102038	● 101978
1/2	14	100	26	16	12		● 101962	● 102022	● 102032	● 101972
3/4	14	110	26	20	16		● 101967	● 102027	● 102037	● 101977
1	11.5	125	32	25	20		● 101965	● 102025	● 102035	● 101975
1 1/4	11.5	125	32	32	24		● 101960	● 102020		
1 1/2	11.5	140	32	36	29		● 101959	● 102019		
2	11.5	160	32	36	29		● 101966	● 102026		

NPT, NPTF	Vc (m/min) Ø d1 - Guide Line			
	1/16" - 1/4"	3/8" - 1/2"	3/4" - 1"	1.1/4" - 2"
	6	5	4	3
	5	4	3	2
	10	8	7	5
	18	15	13	10

NPT, NPTF

ASME B1.20.1, ANSI B1.20.3

HSSE

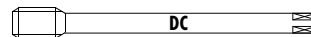

					D5800			
D5800 								
Ø" NPT, NPTF	l₁ mm	l₂ mm	d₂ mm	a mm	ID			
1/16	70	17	6	4.9	● 118701			
1/8	70	17	8	6.2	● 110531			
1/4	80	27	10	8	● 110530			
3/8	85	27	12	9	● 110535			
1/2	95	35	16	12	● 110529			
3/4	105	35	20	16	● 110534			
1	130	43	25	20	● 110532			

Диаметр отверстия под резьбы NPT и NPTF Core hole diameters for NPT and NPTF threads

Отверстие с параллельными стенками
Повышенный износ, не рекомендуется

Parallel hole
Increased tap wear, not recommended

*Рекомендуется конич. развертывание до D₃

*Taper-ream at upper limit D₃ is recommended

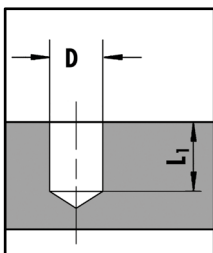

Коническое отверстие 1:16
Предварительное отв. Ø D₂ и развертывание до Ø D₃

Tapered hole 1:16
Pre-drill at Ø D₂ and taper-ream to Ø D₃

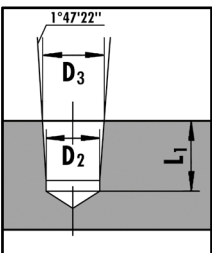

Коническое отверстие
Заход метчика на глубину L₃=номинальный диаметр

Tapped hole
Engage tap to hole depth L₃ = nominal Ø

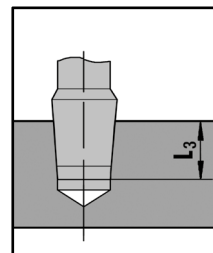



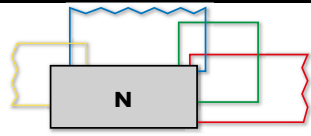
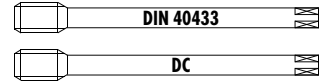

Ø" NPT, NPTF	D mm	L ₁ mm	D ₂ mm	NPT	NPTF	L ₃ mm
				D ₃ (+0.05) mm	D ₃ (+0.05) mm	
1/16	6.15	12	6	6.39	6.41	10.2
1/8	8.5	12	8.3	8.74	8.76	10.3
1/4	11	17.5	10.8	11.36	11.4	15.1
3/8	14.5	17.5	14.2	14.8	14.84	15.3
1/2	17.9	23	17.5	18.32	18.33	20
3/4	23.2	23	22.8	23.67	23.68	20.5
1	29	28	28.6	29.69	29.72	24.6

PG DIN 40430 TR ISO 2901-2904, DIN 103



HSSE



N420-3  

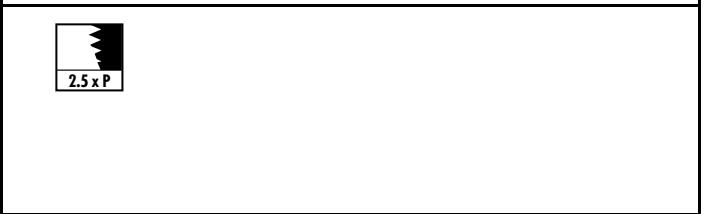
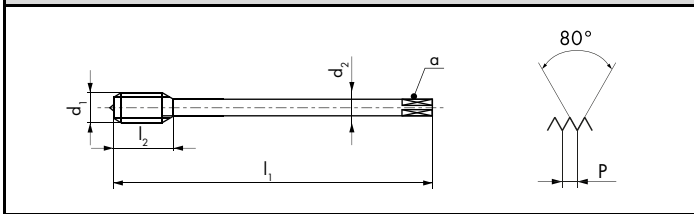
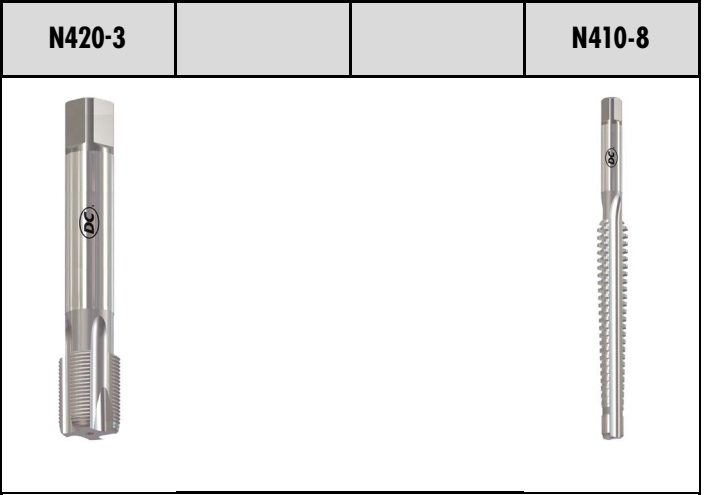

N410-8   

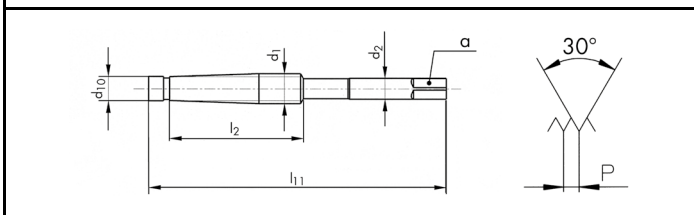

Ø d ₁ PG	P TPI	d ₁ mm	l ₁ mm	l ₂ mm	d ₂ mm	a mm			ID
7	20	12.5	100	24	9	7	3	11.3	● 104901
9	18	15.2	100	26	12	9	3	13.9	● 104902
11	18	18.6	110	26	14	11	4	17.3	● 104903
13.5	18	20.4	125	28	16	12	4	19.1	● 104904
16	18	22.5	125	28	18	14.5	4	21.2	● 104905
21	16	28.3	150	36	22	18	4	26.8	● 104906
29	16	37	170	38	28	22	4	35.5	● 104907
36	16	47	190	38	36	29	5	45.5	● 104908

ID
● 104901
● 104902
● 104903
● 104904
● 104905
● 104906
● 104907
● 104908







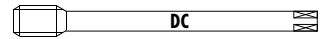



















Ø d ₁ TR	P mm	l ₁₁ mm	l ₂ mm	d ₁₀ mm	d ₂ mm	a mm			ID
10	2	100	45	8.2	7	5.5	3	8.2	● 102008
12	3	140	75	9.25	8	6.2	3	9.25	● 102009
14	3	150	75	11.25	10	8	3	11.25	● 102010
16	4	180	100	12.25	11	9	3	12.25	● 102011
18	4	180	100	14.25	12	9	3	14.25	● 102012
20	4	190	100	16.25	14	11	3	16.25	● 102013
22	5	220	110	17.25	16	12	4	17.25	● 111616
24	5	220	110	19.25	18	14.5	4	19.25	● 102015

ID
● 102008
● 102009
● 102010
● 102011
● 102012
● 102013
● 111616
● 102015



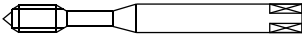





































































































































										N410-1	N410-2	N410-3	N410-S
N410-1													
N410-2													
N410-3													
N410-S													
										<div style="border: 1px solid black; padding: 5px; display: inline-block;">7H</div>		<div style="border: 1px solid black; padding: 5px; display: inline-block;">7H</div>	
Ø d₁ TR	P mm	l₁₁ mm	l₂ mm	d₁₀ mm	d₂ mm	a mm				ID	ID	ID	ID
10	2	85	30	8.2	7	5.5	3	8.2		* 101827	* 101838	* 101979	* 110972
16	4	165	65	12.25	11	9	3	12.25		* 101830	* 101841	* 101982	* 110975
<p>Из-за низкого спроса мы больше не держим комплекты TR tap в нашей стандартной программе. По запросу мы будем рады предложить их в качестве заказных изделий, цена и срок поставки по запросу.</p> <p>Due to low demand, we no longer keep TR tap sets in our standard programme. On request, we will be pleased to offer these as custom-made products, price and delivery time on demand.</p>													

	N				Z	S	
Характеристики Characteristics 		 V	 R40	 R40 V	 R45 VS	 VS	 R35 VS
							
Тип отверстия Hole type							
	N320-4	N320V-4	N360-3	N360V-3	Z370VS-3	S320VS-4	S360VS-3
Длинный по DIN DIN long ~DIN 40435	226	226	227	227			
Длинный по DIN DIN long ~DIN 2184-1	230 / 233		230 / 233		231 / 234	234	234
Резьба Thread EG M	226	226	227	227			
Резьба Thread EG UNC	230		230		231		
Резьба Thread EG UNF	233		233		234	234	234
	N420-4	N420V-4	N460-3	N460V-3			
Длинный по DIN DIN long ~DIN 40435	226	226	227	227			
Длинный по DIN DIN long ~DIN 2184-1	230 / 233		230 / 233				
Резьба Thread EG M	226	226	227	227			
Резьба Thread EG UNC	230		230				
Резьба Thread EG UNF	233		233				

EG

Указатель — Машинные метчики для резьбовых вставок EG M, EG UNC, EG UNF
 Directory — Machine taps for wire screw thread inserts EG M, EG UNC, EG UNF

SA			TL	
				
				
				
				
				
				
				
				
				
				
				
				
				
				
				
				
				
				
				
				
				
				
				
				
				
				
				

EG M ISO DIN 8140



≤ Ø 2.8 > Ø 2.8

PM

HSSE

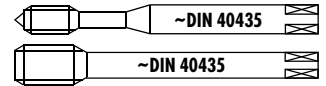

										N320-4	N320V-4	N420-4	N420V-4
N320-4													
N320V-4													
N420-4													
N420V-4													
Ø d ₁ EG M	P mm	d ₁ mm	l ₁ mm	l ₂ mm	l ₃ mm	d ₂ mm	a mm			ID	ID	ID	ID
2	0.4	2.52	50	10		2.8	2.1	3	2.1	● 101537	● 118788		
2.5	0.45	3.08	56	12	18	3.5	2.7	3	2.65	● 101538			
3	0.5	3.65	56	13	20	4	3	3	3.15	● 101539	● 142804		
4	0.7	4.91	70	15	25	6	4.9	3	4.2	● 101540	● 142805		
5	0.8	6.04	80	17	30	6	4.9	3	5.25	● 101541	● 142806		
6	1	7.3	80	17	30	7	5.5	3	6.3	● 101542	● 142807		
8	1.25	9.62	100	22	39	10	8	3	8.4	● 101543	● 142808		
10	1.5	11.94	100	24		9	7	3	10.4			● 102252	● 142809
12	1.75	14.27	110	28		11	9	3	12.5			● 102253	● 142810
16	2	18.59	125	33		14	11	3	16.6			● 102255	● 142812

EG M ISO DIN 8140



≤ Ø 2.8 > Ø 2.8

PM HSSE

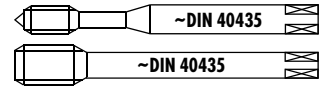

										N360-3	N360V-3	N460-3	N460V-3
N360-3		63 72 73 74 81 91											
N360V-3			11 12 32										
N460-3		63 72 73 74 81 91											
N460V-3			11 12 32										
Ø d ₁ EG M	P mm	d ₁ mm	l ₁ mm	l ₂ mm	l ₃ mm	d ₂ mm	a mm			ID	ID	ID	ID
2	0.4	2.52	50	9		2.8	2.1	2	2.1	● 101599			
2.5	0.45	3.08	56	5.5	18	3.5	2.7	3	2.65	● 101600			
3	0.5	3.65	56	6.5	20	4	3	3	3.15	● 101601	● 142813		
4	0.7	4.91	70	9	25	6	4.9	3	4.2	● 101602	● 142814		
5	0.8	6.04	80	11	30	6	4.9	3	5.25	● 101603	● 142815		
6	1	7.3	80	11	30	7	5.5	3	6.3	● 101604	● 142816		
8	1.25	9.62	100	14	39	10	8	3	8.4	● 101605	● 142817		
10	1.5	11.94	100	14		9	7	3	10.4			● 102335	● 142818
12	1.75	14.27	110	14		11	9	3	12.5			● 102336	● 142819
14	2	16.59	110	18		12	9	3	14.6			● 102337	● 142820
16	2	18.59	125	21		14	11	3	16.6			● 102338	● 142821



PM

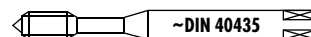

aero

SA320-4



15 16 52 64

SA350-3



15 16 52 64

TL351VS-3



VS

41 42

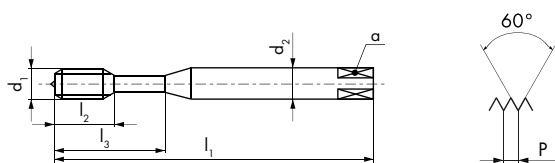

SA320-4

SA350-3

TL351VS-3



6H mod

6H mod

6H mod

$\emptyset d_1$ EG M	P mm	d_1 mm	l_1 mm	l_2 mm	l_3 mm	d_2 mm	a mm			ID	ID	ID
3	0.5	3.65	56	13		4	3	3	3.15	● 147676	● 147682	● 150478
4	0.7	4.91	70	15		6	4.9	3	4.2	● 147678	● 147684	● 152003
5	0.8	6.04	80	15	23	6	4.9	3	5.25	● 147680	● 147686	● 150184
6	1	7.3	80	15	23	7	5.5	3	6.3	● 147688	● 147692	● 152005
8	1.25	9.62	100	20	33	10	8	3	8.4	● 149354	● 149356	● 152089

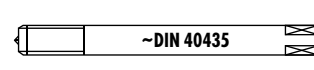

aero

SA390-3



16 53

SA390-3

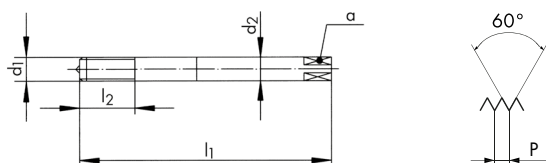

$\emptyset d_1$ EG M	P mm	d_1 mm	l_1 mm	l_2 mm	d_2 mm	a mm		
3	0.5	3.65	56	13	4	3	3	3.15
4	0.7	4.91	70	15	6	4.9	3	4.2
5	0.8	6.04	80	20	6	4.9	3	5.25
6	1	7.3	80	20	7	5.5	3	6.3
8	1.25	9.62	100	30	10	8	3	8.4
10	1.5	11.94	110	35	12	9	3	10.4

ID

- 149669
- 149688
- 149710
- 149723
- 149748
- 149767

EG UNC ASME B18.29.1



HSSE

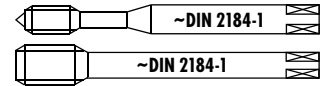

											N320-4	N420-4	N360-3	N460-3	
N320-4		62 63 64 72 73 74 81 91													
N420-4		62 63 64 72 73 74 81 91													
N360-3		63 72 73 74 81 91													
N460-3		63 72 73 74 81 91													
Ø" d ₁ EG UNC	P TPI	d ₁ mm	l ₁ mm	l ₂ mm	l ₃ mm	d ₂ mm	a mm				ID	ID	ID	ID	
4	40	3.67	56	13	20	4	3	3	3.05	●	110946				
6	32	4.53	70	15	25	6	4.9	3	3.75	●	110948				
8	32	5.19	70	15	25	6	4.9	3	4.45	●	110949				
1/4	20	8	90	20	35	8	6.2	3	6.7	●	110944				
5/16	18	9.77	100	22	39	10	8	3	8.4	●	110947				
3/8	16	11.58	110	24		9	7	3	10			●	110033		
1/2	13	15.23	110	30		12	9	3	13.3			●	104935		
Ø" d ₁ EG UNC	P TPI	d ₁ mm	l ₁ mm	l ₂ mm	l ₃ mm	d ₂ mm	a mm				ID	ID	ID	ID	
4	40	3.67	56	6.5	20	4	3	3	3.05			●	110018		
6	32	4.53	70	9	25	6	4.9	3	3.75			●	110019		
8	32	5.19	70	9	25	6	4.9	3	4.45			●	110956		
10	24	6.2	80	11	30	7	5.5	3	5.1			●	110954		
1/4	20	8	90	12.5	35	8	6.2	3	6.7			●	110024		
5/16	18	9.77	100	14	39	10	8	3	8.4			●	111759		
3/8	16	11.58	110	14		9	7	3	10					●	111715
1/2	13	15.23	110	18		12	9	3	13.3					●	111558

EG UNC ASME B18.29.1



PM

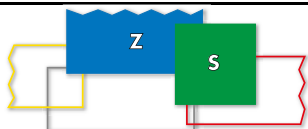
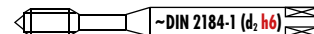

Z370VS-3

Z370VS-3



VS



Z370VS-3



VS

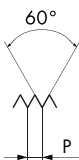
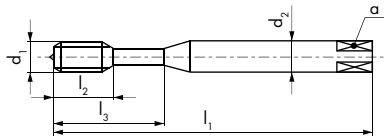

3B

$\emptyset d$ EG UNC	P TPI	d_1 mm	l_1 mm	l_2 mm	l_3 mm	d_2 h6 mm	a mm		
4	40	3.67	56	6.5	20	4(h9)	3	3	3.05
6	32	4.53	70	9	25	6	4.9	3	3.75
8	32	5.19	70	9	25	6	4.9	3	4.45

ID

- 165126
- 165127
- 165128

EG UNC ASME B18.29.1



PM



aero

										SA320-4	SA350-3	TL320VS-4	TL351VS-3						
<div style="display: flex; justify-content: space-between;"> <div style="width: 45%;"> <p>SA320-4 15 16 52 64</p> <p>SA350-3 15 16 52 64</p> </div> <div style="width: 50%; text-align: center;"> </div> </div>																			
<div style="display: flex; justify-content: space-between;"> <div style="width: 45%;"> <p>TL320VS-4 41 42</p> <p>TL351VS-3 41 42</p> </div> <div style="width: 50%; text-align: center;"> </div> </div>																			
										<div style="display: flex; justify-content: space-around;"> <div style="text-align: center;"> 3B </div> <div style="text-align: center;"> 3B </div> <div style="text-align: center;"> 3B </div> <div style="text-align: center;"> 3B </div> </div>									
\emptyset " d ₁ EG UNC	P TPI	d ₁ mm	l ₁ mm	l ₂ mm	l ₃ mm	d ₂ mm	a mm			ID	ID	ID	ID						
4	40	3.67	56	13		4	3	3	3.05	● 149073	● 149075		● 152031						
6	32	4.53	70	15		6	4.9	3	3.75	● 149121	● 149123	* 152040	● 152041						
8	32	5.19	70	15		6	4.9	3	4.45	● 149170	● 149172		● 152053						
1/4	20	8	90	18	29	8	6.2	3	6.7	● 149284	● 149286	* 152073	● 152074						
5/16	18	9.77	100	20	33	10	8	3	8.4		* 149360								

EG UNF ASME B18.29.1



HSSE

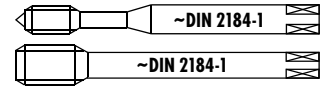

											N320-4	N420-4	N360-3	N460-3
N320-4		62 63 64 72 73 74 81 91												
N420-4		62 63 64 72 73 74 81 91												
N360-3		63 72 73 74 81 91												
N460-3		63 72 73 74 81 91												
$\emptyset'' d_1$ EG UNF	P TPI	d_1 mm	l_1 mm	l_2 mm	l_3 mm	d_2 mm	a mm			ID	ID	ID	ID	
6	40	4.33	63	14	21	4.5	3.4	3	3.7	● 118879				
8	36	5.08	70	15	25	6	4.9	3	4.4	● 118882				
10	32	5.85	80	17	30	6	4.9	3	5.1	● 104941				
1/4	28	7.52	90	20	35	8	6.2	3	6.65	● 110234				
5/16	24	9.31	90	20	35	9	7	3	8.2	● 118876				
3/8	24	10.89	100	19		8	6.2	3	9.8		● 118873			
1/2	20	14.35	100	24		11	9	3	13.1		● 118865			
$\emptyset'' d_1$ EG UNF	P TPI	d_1 mm	l_1 mm	l_2 mm	l_3 mm	d_2 mm	a mm			ID	ID	ID	ID	
6	40	4.33	63	7.5	21	4.5	3.4	3	3.7		● 110959			
8	36	5.08	70	9	25	6	4.9	3	4.4		● 110960			
10	32	5.85	80	11	30	6	4.9	3	5.1		● 104946			
1/4	28	7.52	90	12.5	35	8	6.2	3	6.65		● 110020			
5/16	24	9.31	90	12.5	35	9	7	3	8.2		● 111619			
3/8	24	10.89	100	19		8	6.2	3	9.8			● 110027		
1/2	20	14.35	100	14		11	9	3	13.1			● 104951		

EG UNF ASME B18.29.1



PM

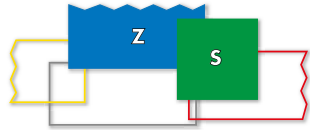
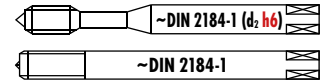

Z370VS-3				14 15 21 22 23 24 51 61 94
Z370VS-3				13 14 15 21 22 23 24 51 52
S320VS-4				13 15 16 22 23 24 52
S360VS-3				13 15 16 22 23 24 52
SA390-3		aero		16 53

Z370VS-3	S320VS-4	S360VS-3	SA390-3

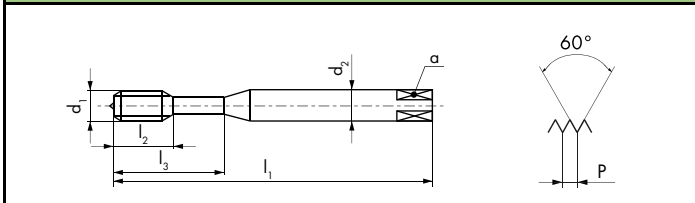

C 2.5 x P	B 4 x P	C 2.5 x P	C 2.5 x P
3B	3B	3B	3B

Ø" d1 EG UNF	P TPI	d1 mm	l1 mm	l2 mm	l3 mm	d2 h6 mm	a mm			ID
10	32	5.85	80	11	30	6	4.9	3	5.1	● 165129
1/4	28	7.52	90	12.5	35	8	6.2	3	6.65	● 165130
5/16	24	9.31	90	12.5	35	* 8	* 6.2	3	8.2	● 165131
* Norme DC / * DC Norm/ * Norma DC										

ID
● 111821
● 111822
● 111823

Ø" d1 EG UNF	P TPI	d1 mm	l1 mm	l2 mm	l3 mm	d2 mm	a mm			ID
10	32	5.85	80	17	30	6	4.9	3	5.1	● 111821
1/4	28	7.52	90	20	35	8	6.2	3	6.65	● 111822
5/16	24	9.31	90	20	35	9	7	3	8.2	● 111823

ID
● 111811
● 111812
● 111824

Ø" d1 EG UNF	P TPI	d1 mm	l1 mm	l2 mm	l3 mm	d2 mm	a mm			ID
10	32	5.85	80	20		6	4.9	3	5.1	● 149702
1/4	28	7.52	90	25		8	6.2	3	6.65	● 149724

ID
● 149702
● 149724

EG UNF ASME B18.29.1



PM

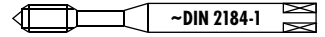

aero

SA320-4



15 16 52 64

SA350-3



15 16 52 64

TL351VS-3



41 42

SA320-4

SA350-3

TL351VS-3



< 1.5 x D

< 2 x D



< 2 x D

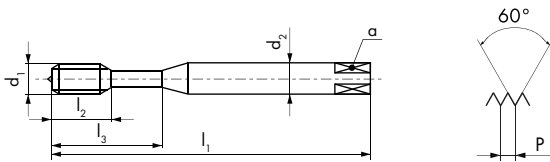

4 x P

2.5 x P

2.5 x P



3B

3B

3B

Ø" d ₁ EG UNF	P TPI	d ₁ mm	l ₁ mm	l ₂ mm	l ₃ mm	d ₂ mm	a mm		
10	32	5.85	80	15	23	6	4.9	3	5.1
1/4	28	7.52	90	18	29	8	6.2	3	6.65
5/16	24	9.31	90	20	31	9	7	3	8.2

ID	ID	ID
● 149190	● 149192	● 148008
● 146099	● 149268	● 148014
● 149336	● 149338	● 148021

Общая информация

Корончатый метчик DC с рабочей поверхностью, „V”-обработанной для предотвращения холодной сварки, является высокопроизводительным инструментом, обеспечивающим высокое качество поверхности нарезаемой резьбы.

Сфера применения

Благодаря внутренней емкости для стружкоотвода во фронтальной части, корончатые метчики DC могут быть использованы для нарезания резьбы как в сквозных, так и в глухих отверстиях. Корончатый метчик может быть использован для материалов с пределом прочности до 850 Н/мм² и коэффициентом удлинения максимум 30%

Использование

для оптимального нарезания в глухих отверстиях, отверстие под резьбу должно быть соответствующим и следующие инструкции должны выполняться:

- Нарезайте резьбу до срабатывания предохранительной муфты патрона
- Выверните метчик и очистите от стружки
- Нарезайте резьбу на полную глубину

Общие указания

Эффективная работа корончатых метчиков DC, также как и качество нарезаемой резьбы, зависят от соблюдения следующих правил:

- Не превышайте максимально допустимую погрешность центрирования инструмента в 0.1 мм
- Метчик должен двигаться соосно отверстию, используйте резьбонарезной патрон
- Нарезайте резьбу с рекомендованной скоростью
- Выбирайте СОЖ в зависимости от материала, в котором будет нарезаться резьба
- Используйте патрон с осевой компенсацией и предохранительной муфтой
- Отрегулируйте предохранительную муфту таким образом, чтобы она срабатывала при достижении

Когда нарезаете первую резьбу, ослабьте предохранительную муфту до проскальзывания, затем постепенно затяните, пока метчик не начнет вращаться.

Сбор стружки

Объем стружкоотводящей емкости рассчитан на следующую глубину:

Диаметр резьбы	Ø 20 - 29 mm	≥ Ø 30 mm
M	-	1.4 x D
MF	1.2 x D	1.4 x D
UN-8	-	1.4 x D
G	1.2 x D	1.4 x D

General information

The DC crown tap with "V" surface treatment to prevent cold welding is a tool of high performance, which offers a very high quality surface finish of the tapped threads.

Application rang

Thanks to the front recess providing space for the chip collection, the DC crown tap is suitable for both, through and blind hole tapping. The crown tap can be used for materials with a tensile strength up to 850 N/mm² and an elongation of maximum 30 %.

Utilization

For an optimal blind hole threading, the core hole depth must be adapted accordingly and the following application instructions must be followed:

- tap until tapping head clutch slips
- retract tap and clear chips
- tap to the full depth.

General hints

The efficient operation of DC crown taps, as well as the quality of the cut threads, depend on observation of the following rules:

- do not exceed the maximum permissible centering error of 0.1 mm
- the tap must run concentrically, use a suitable tapping head
- tap at the correct cutting speed
- select a coolant to suit the material being tapped
- use a tapping head with axial compensation and safety clutch
- set the safety clutch so that it will slip at just above the tapping torque.

When tapping the first hole, slacken the clutch until it slips, then gradually tighten it until the tap is driven.

Chip accumulation

The chip accumulation capacity of the recess is the following:

Thread diameter	Ø 20 - 29 mm	≥ Ø 30 mm
M	-	1.4 x D
MF	1.2 x D	1.4 x D
UN-8	-	1.4 x D
G	1.2 x D	1.4 x D

Скорости резания и обороты шпинделя (рекомендованные) - Cutting and spindle speeds (guide values)

M	P	V _c (m/min)	n ⁿ (U/min)	MF	P	V _c (m/min)	n ⁿ (U/min)	MF	P	V _c (m/min)	n ⁿ (U/min)	UN-8			
												P	TPI	V _c (m/min)	n ⁿ (U/min)
30	3.5	7.9	84	22	1.5	8.0	116	45	1.5	6.9	49	1 1/4"	8	7.8	77
33	3.5	7.7	74	24	1.5	8.0	106	45	2.0	6.9	49	1 3/8"	8	7.6	69
36	4.0	7.5	66	26	1.5	7.9	97	48	1.5	6.6	44	1 1/2"	8	7.3	62
39	4.0	7.3	60	28	1.5	7.9	90	48	2.0	6.6	44	1 5/8"	8	7.1	55
42	4.5	7.1	54	30	1.5	7.9	84	48	3.0	6.6	44	1 3/4"	8	6.9	49
45	4.5	6.9	49	30	2.0	7.9	84	48	4.0	6.6	44	1 7/8"	8	6.7	45
48	5.0	6.6	44	32	1.5	7.8	77	50	1.5	6.5	41	2"	8	6.4	40
52	5.0	6.4	39	32	2.0	7.8	77	52	1.5	6.4	39	2 1/8"	8	6.4	38
56	5.5	6.1	35	33	1.5	7.7	74	52	3.0	6.4	39	2 1/4"	8	6.1	34
60	5.5	5.8	31	33	2.0	7.7	74	55	1.5	6.2	36	2 1/2"	8	5.6	28
64	6.0	5.5	28	34	1.5	7.6	71	56	4.0	6.1	35	G			
68	6.0	5.2	25	35	1.5	7.6	69	60	2.0	5.8	31				
				36	1.5	7.5	66	64	4.0	5.5	28	3/4"	14	7.9	95
				36	2.0	7.5	66	68	4.0	5.2	25	1"	11	7.7	74
				36	3.0	7.5	66	72	6.0	5.0	22	1 1/4"	11	7.1	54
				38	1.5	7.3	62	76	6.0	4.7	20	1 1/2"	11	6.6	44
				40	1.5	7.2	57	80	2.0	4.4	18	1 3/4"	11	6.3	37
				40	2.0	7.2	57	80	4.0	4.4	18	2"	11	5.8	31
				42	1.5	7.1	54	80	6.0	4.4	18				
				42	2.0	7.1	54	90	6.0	3.7	13				
				42	3.0	7.1	54	100	6.0	3.0	10				
				42	4.0	7.1	54	110	6.0	2.5	7				

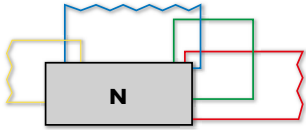

N470V-4



11 12 13 14 21 32

N470V-4

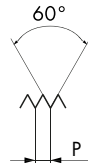
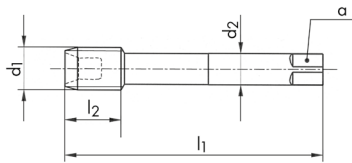

$\emptyset d_1$ M	P mm	l_1 mm	l_2 mm	d_2 mm	a mm			ID
30	3.5	180	39	22	18	5	26.5	● 102575
33	3.5	180	39	22	18	5	29.5	★ 102576
36	4	200	43	25	20	5	32	● 102577
39	4	200	43	25	20	5	35	● 102578
42	4.5	220	47	28	22	5	37.5	● 102579
45	4.5	220	47	28	22	5	40.5	● 102580
48	5	240	52	32	24	5	43	● 102581
52	5	240	52	32	24	5	47	● 102582
56	5.5	260	58	36	29	6	50.5	● 102583
60	5.5	260	58	36	29	6	54.5	● 102584
64	6	290	64	40	32	6	58	● 102585
68	6	290	64	40	32	6	62	★ 102586

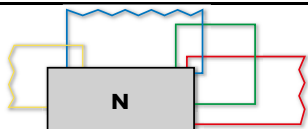

N470V-3



11 12 13 14 21 32

N470V-3

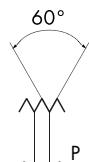
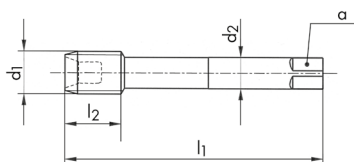

$\emptyset d_1$ MF	P mm	l_1 mm	l_2 mm	d_2 mm	a mm			ID
$\Delta 22$	1.5	125	28	18	14.5	4	20.5	* 102526
$\Delta 26$	1.5	140	30	18	14.5	4	24.5	* 102529
$\Delta 28$	1.5	140	30	20	16	4	26.5	* 102530
30	1.5	160	32	22	18	5	28.5	* 102531
34	1.5	160	26	22	18	5	32.5	* 102537
35	1.5	175	28	25	20	5	33.5	* 102538
36	2	175	35	25	20	5	34	● 102540
36	3	200	43	25	20	5	33	● 102541
38	1.5	175	28	25	20	5	36.5	* 102542
40	2	190	38	28	22	5	38	* 102544
42	2	190	38	28	22	5	40	● 102546
42	3	220	47	28	22	5	39	● 102547
48	1.5	205	34	32	24	5	46.5	* 102551
48	3	205	41	32	24	5	45	● 102553
52	3	205	41	32	24	5	49	● 102557
56	4	260	58	36	29	6	52	● 102559
64	4	290	64	40	32	6	60	● 102561
80	4	270	56	45	35	7	76	* 102564



Other sizes from $\emptyset 30$ to 160 mm on request!



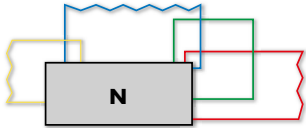

N470V-3



11 12 13 14 21 32

N470V-3

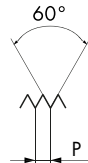
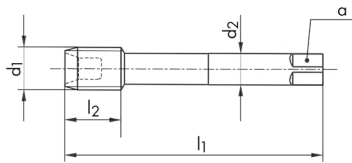

2B

Ø" d ₁ UN	P TPI	d ₁ mm	l ₁ mm	l ₂ mm	d ₂ mm	α mm			ID
1 1/4	8	31.75	180	39	22	18	5	28.7	● 102566
1 3/8	8	34.92	180	39	22	18	5	31.8	● 102568
1 1/2	8	38.1	200	43	25	20	5	35	● 102565
1 5/8	8	41.27	220	47	28	22	5	38.2	● 102569
1 3/4	8	44.45	220	47	28	22	5	41.4	● 102567
1 7/8	8	47.62	240	52	32	24	5	44.5	● 102570
2	8	50.8	205	41	32	24	5	47.7	● 102572
2 1/8	8	53.97	205	41	32	24	5	50.9	★ 143542
2 1/4	8	57.15	220	45	36	29	6	54.1	● 102571
2 1/2	8	63.5	220	45	36	29	6	60.4	● 111879

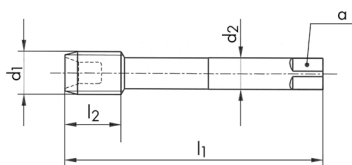

Ø" d ₁ G	P TPI	d ₁ mm	l ₁ mm	l ₂ mm	d ₂ mm	α mm			ID
Δ 3/4	14	26.44	150	34	20	16	4	24.4	● 102525
1	11	33.24	160	32	22	18	5	30.7	● 102522
1 1/4	11	41.91	190	38	28	22	5	39.3	● 102519
1 1/2	11	47.8	205	41	32	24	5	45.2	● 102518
1 3/4	11	53.74	205	41	32	24	5	51.2	★ 102520
2	11	59.61	220	45	36	29	6	57	● 102524



КОМБИНИРОВАННЫЕ СВЕРЛА/МЕТЧИКИ

Общая информация

DC комбинированные сверла/метчики – два инструмента в одном, который позволяет сверлить и нарезать резьбу не меняя инструмента.

Являются оптимальным решением для станков с ЧПУ, сверлильных головок, револьверных и резьбонарезных станков.

Сфера применения

DC комбинированные сверла/метчики рекомендуется использовать по материалам с пределом прочности до 750 Н/мм², таким как определенные стали, чугун, алюминий, латунь.

Общие положения

- Отверстие под резьбу должно быть полностью просверлено до того как метчик начнет нарезание.
- В короткостружечных материалах глубина резьбы не должна превышать 1.8 x D (тип N5952 до 2 x D).
- В короткостружечных материалах глубина резьбы не должна превышать 1.2 x D.
- Смазка как при нарезании резьбы.

Скорости резания

Для сверлильных головок и станков с ЧПУ, идеальные скорости сверления и нарезания резьбы подобраны (см. таблицы применимости).

Если для сверления и нарезания резьбы выбираются одинаковые скорости, мы рекомендуем значения, приведенные ниже.

Инструкции по программированию

Зенкование:

Центровка и зенкование одновременно.

Программирование для 100 % синхронизированной подачи шпинделя и вращения (идеальный случай):

- 1) Комбинированное сверло/метчик в позиции быстрого старта
- 2) Сверление:
 - установить скорость
 - установить подачу
 - избегать длинной стружки
 - очистить стружку
- 3) Резьбонарезная секция в позиции старта
- 4) Нарезание резьбы:
 - установить скорость
 - подача = 100 % шаг резьбы
 - установить глубину резьбы
 - перед началом работы метчик должен быть очищен от стружки
- 5) Комбинированный сверло/метчик возвращается в позицию старта.

Программирование для случаев когда подача шпинделя и вращение не полностью синхронизированы:

Важно: Установите комбинированное сверло-метчик в патрон, защелкнув пружину, но вытянув осевую компенсацию.

- 1) Комбинированное сверло/метчик в позиции быстрого старта
- 2) Сверление:
 - установить скорость
 - установить подачу
 - избегать длинной стружки
 - очистить стружку
- 3) Резьбонарезная секция в позиции старта
- 4) Нарезание резьбы:
 - Установить скорость
 - подача = 90 - 95 % шага резьбы
 - установить глубину резьбы
- 5) Комбинированный сверло/метчик возвращается в позицию старта.

Скорости резания и вращения шпинделя (рекомендованные значения)

Группы материалов	Vc (m/min)	Скорости для различных диаметров										
		M3	M4	M5	M6	M8	M10	M12	M14	M16	M18	M20
Стали до 500 Н/мм ²	20	2120	1600	1270	1060	800	640	530	460	400	360	320
Стали свыше 500 Н/мм ²	15	1600	1200	950	800	600	480	400	340	300	270	240
Чугун, мягкий	20	2120	1600	1270	1060	800	640	530	460	400	360	320
Чугун, твердый	15	1600	1200	950	800	600	480	400	340	300	270	240
Латунь	25	2650	2000	1600	1330	950	800	660	570	500	450	400
Алюминий	25	2650	2000	1600	1330	950	800	660	570	500	450	400

COMBINATION DRILL/TAPS

General information

DC combination drill/taps - two tools in one, which allows the drilling and the threading of a workpiece without changing the tool.

It is the optimal solution for CNC-machines, drilling heads, turret lathes and tapping machines.

Application rang

DC combination drill/taps are recommended for use in materials with a tensile strenght up to 750 N/mm², such as certain steels, cast iron, aluminium, brass.

General hints

- The core hole must be completely drilled through before the tap starts cutting.
- In short chipping materials, the depth of thread should not exceed 1.8 x D (type N5952 up to 2 x D).
- In long chipping materials, the depth of thread should not exceed 1.2 x D.
- Lubricate as for tapping.

Cutting speeds

On drilling heads and CNC-machines, the ideal speeds for drilling and tapping are selected (see our application chart). If the same speed is selected for both drilling and tapping, we recommend the values indicated below.

Programming instructions

Countersinking:

Center and countersink simultaneously.

Programming steps for spindle feed and rotation 100 % synchronised (ideal case):

- 1) Combi-drill-tap in rapid to start position
- 2) Drilling:
 - set speed
 - set feed
 - avoid long chips
 - clear shavings
- 3) Tapping section in start position
- 4) Tapping:
 - set speed
 - feed = 100 % pitch
 - set thread depth
 - tap must be free of swarf before starting to cut
- 5) Combi-drill-tap returns to start position.

Programming steps for spindle feed rotation not fully synchronised:









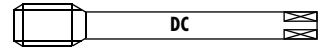

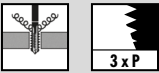
Important: Mount combination drill-tap in chuck with locked pressure spring, but with axial compensation on pull.

- 1) Combi-drill-tap in rapid to start position
- 2) Drilling:
 - set speed
 - set feed
 - avoid long chips
 - clear shavings
- 3) Tapping section in start position
- 4) Tapping:
 - set speed
 - feed = 90 - 95 % pitch
 - set thread depth
- 5) Combi-drill-tap returns to start position.

Cutting and spindle speeds (guide values)

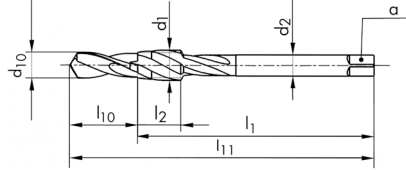
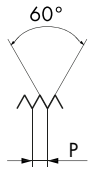
Material groups	Vc (m/min)	Speeds for different diameters										
		M3	M4	M5	M6	M8	M10	M12	M14	M16	M18	M20
Steels up to 500 N/mm ²	20	2120	1600	1270	1060	800	640	530	460	400	360	320
Steels over 500 N/mm ²	15	1600	1200	950	800	600	480	400	340	300	270	240
Cast iron, soft	20	2120	1600	1270	1060	800	640	530	460	400	360	320
Cast iron, hard	15	1600	1200	950	800	600	480	400	340	300	270	240
Brass	25	2650	2000	1600	1330	950	800	660	570	500	450	400
Aluminium	25	2650	2000	1600	1330	950	800	660	570	500	450	400



								N5951	N5952	N5951				
<p>N5951  </p> <p>N5952  </p> <p>N5951  </p>														
 														
$\emptyset d_1$ M	P mm	l_{11} mm	l_2 mm	d_2 mm	a mm	d_{10} mm	l_{10} mm	ID						
3	0.5	62	12.5	3.5	2.7	2.55	9	● 104578						
4	0.7	66	16	4.5	3.4	3.36	10	● 104580						
5	0.8	75.5	18	6	4.9	4.26	12.5	● 104583						
6	1	81	20	6	4.9	5.05	14	● 104585						
8	1.25	93	12	6	4.9	6.8	20	● 104588						
10	1.5	99	14	7	5.5	8.55	22	● 104571						
12	1.75	106	16	9	7	10.3	25	● 104573						
16	2	123	20	12	9	14.1	32	● 104576						
20	2.5	132	22	16	12	17.6	36	● 104577						
$\emptyset d_1$ M	P mm	l_{11} mm	l_2 mm	d_2 mm	a mm	d_{10} mm	l_{10} mm	ID						
4	0.7	77	16	4.5	3.4	3.36	21	● 104608						
5	0.8	87	18	6	4.9	4.26	24	● 104609						
6	1	94	20	6	4.9	5.05	27	● 104610						
8	1.25	109	12	6	4.9	6.8	36	● 104611						
10	1.5	118	14	7	5.5	8.55	41	● 104603						
$\emptyset d_1$ MF	P mm	l_{11} mm	l_2 mm	d_2 mm	a mm	d_{10} mm	l_{10} mm	ID						
4	0.5	66	16	4.5	3.4	3.55	10	★ 104579						
5	0.75	75.5	18	6	4.9	4.31	12.5	★ 123379						
8	1	93	12	6	4.9	7.05	20	● 104587						
10	1	99	14	7	5.5	9.05	22	● 104570						
$\emptyset d_1$ MF	P mm	l_{11} mm	l_2 mm	d_2 mm	a mm	d_{10} mm	l_{10} mm	ID						
12	1.5	106	16	9	7	10.55	25	● 142825						
16	1.5	123	16	12	9	14.55	32	● 142826						
20	1.5	132	18	16	12	18.55	36	● 111844						
25	1.5	155	22	18	14.5	23.55	45	● 111845						
32	1.5	170	24	22	18	30.55	50	● 111846						

UNC ASME B1.1

G DIN EN ISO 228

PG DIN 40430

HSSE

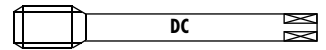

N5951

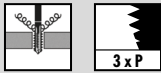

N5951



2B

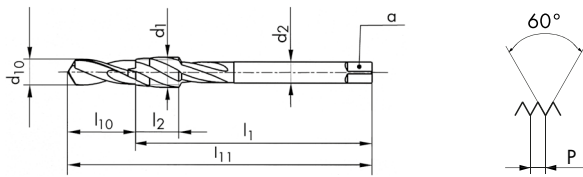

\emptyset d ₁ UNC	P TPI	d ₁ mm	l ₁₁ mm	l ₂ mm	d ₂ mm	a mm	d ₁₀ mm	l ₁₀ mm
6	32	3.5	66	16	4	3	2.8	10
10	24	4.82	75.5	18	4.5	3.4	3.86	12.5
1/4	20	6.35	81	20	7	5.5	5.15	14
1/2	13	12.7	106	16	9	7	10.85	25

ID

- ★ 104601
- 104598
- 104597
- ★ 104596

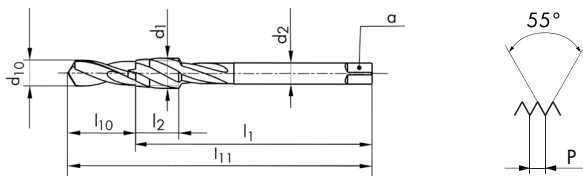

\emptyset d ₁ G	P TPI	d ₁ mm	l ₁₁ mm	l ₂ mm	d ₂ mm	a mm	d ₁₀ mm	l ₁₀ mm
1/8	28	9.72	93	12	7	5.5	8.75	20
1/4	19	13.15	106	14	11	9	11.75	25
3/8	19	16.66	123	16	12	9	15.25	32
1/2	14	20.95	132	18	16	12	19	36

ID

- 104567
- 104566
- 104569
- 104565

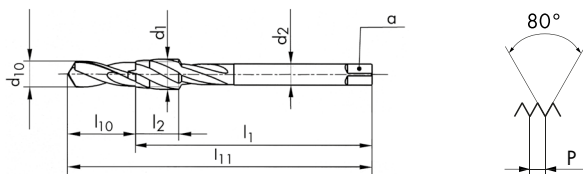

\emptyset d ₁ PG	P TPI	d ₁ mm	l ₁₁ mm	l ₂ mm	d ₂ mm	a mm	d ₁₀ mm	l ₁₀ mm
16	18	22.5	142	20	18	14.5	21.25	40
29	16	37	203	28	28	22	35.65	63

ID

- 104591
- 104593

РАСКАТНИКИ

THREAD FORMING

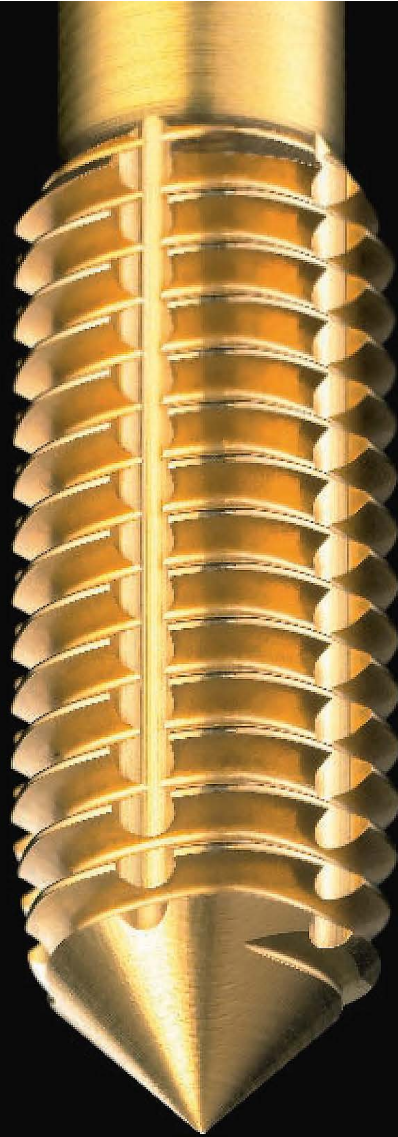

ПО ЗАПРОСУ

Специальные исполнения с адаптированными лепестками для конкретных применений.

ON REQUEST

Special executions with adapted polygon lobes for specific applications.

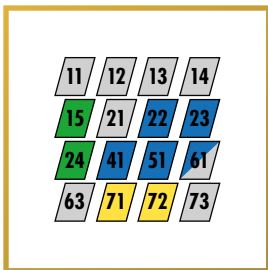

Диапазон применения

Все материалы с относительным удлинением не менее 10% и пределом прочности до 1'150 Н/мм², например стали, нержавеющие стали, чистый титан, алюминий, медь, латунь длинностружечная и т. д.

Range of application

All materials with a minimum of 10 % elongation and a tensile strength of up to 1'150 N/mm², e.g. steels, stainless steels, pure titanium, aluminium, copper, long chipping brass, etc.

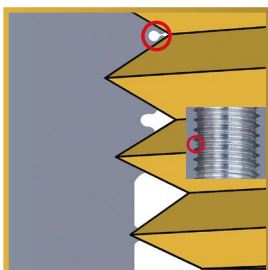

Процесс формования

Отполированные концы и плоские зубья раскатника прокалывают пластичный материал и загоняют его в пространство в профиле инструмента. Это создает профиль резьбы с типичной канавкой в гребне.

Forming process

The polished points and flats of the thread former's teeth pierce the ductile material and force the material into the space in the tool profile. This creates the thread profile with its typical groove in the crest.



Преимущества

- Более высокая технологическая безопасность за счет отсутствия стружки.
- Один инструмент для обоих, сквозных и глухих отверстий.
- Оптимален для глубокой резьбы.
- Резьба с более устойчива к срезанию под статической и динамической нагрузкой.

Advantages

- Higher process security due to the lack of shavings.
- Only one tool for both, through and blind holes.
- Optimal for deep threads.
- Thread with higher resistance of stripping by static and dynamic load.



Ограничение применения

По физическим причинам формирование резьбы в тонкостенных заготовках следует проводить с должной осторожностью.

Application restriction

For physical reasons, thread forming in thin-walled workpieces should be carried out with due care.



Достаточная смазка

Процесс формирования резьбы создает значительное трение. Поэтому инструмент должен быть защищен пленкой смазки. Если подача смазки прервется, то быстро произойдет холодная сварка, что приведет к выходу инструмента из строя.

Adequate lubrication

The thread forming process generates considerable friction. Therefore the tool must be protected by a film of lubricant. If the supply of lubricant is interrupted, then cold welding will quickly occur, resulting in tool failure.

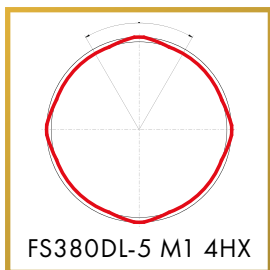

FS380DL-5 M1 4HX

Раскатчик FS-DL

Универсальный раскатчик с 4 формообразующими лепестками для небольших размеров резьбы $\varnothing \geq 1 - < 3$ мм, во всех материалах холодной штамповки. С износостойким покрытием "DLC" с отличными смазочными и скользящими свойствами. Для нержавеющей стали, чистой меди и т. д.

Thread former FS-DL

Universal thread former with 4 forming lobes for small thread sizes $\varnothing \geq 1 - < 3$ mm, in all cold forming materials. With "DLC" wear-protective coating with excellent lubrication and sliding properties. For stainless steels, pure copper, etc.

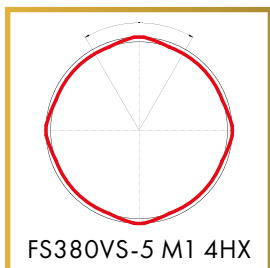

FS380VS-5 M1 4HX

Раскатчик FS-VS

Универсальный резьбообразователь с 4 формообразующими лепестками для небольших размеров резьбы $\varnothing \geq 1 - < 3$ мм, во всех материалах холодной штамповки. С износостойким покрытием DC "VS" с высокими скользящими свойствами.

Thread former FS-VS

Universal thread former with 4 forming lobes for small thread sizes $\varnothing \geq 1 - < 3$ mm, in all cold forming materials. With DC "VS" tool wear protective coating with high sliding properties.

NEW

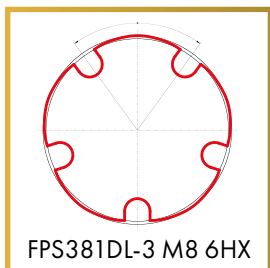

FPS381DL-3 M8 6HX

Раскатчик FPS-DL

Для $\varnothing \geq 3$ мм, с большими формовочными лепестками, предназначенными для поступательного движения абразивных материалов. С износостойким покрытием "DLC" для лучшего скольжения и долгого срока службы инструмента по длинностружечной латуни и алюминию.

Thread former FPS-DL

For $\varnothing \geq 3$ mm, with large forming lobes designed for a progressive flow of abrasive materials. With "DLC" wear-protective coating for better gliding and high tool life in long chipping brass and aluminium.

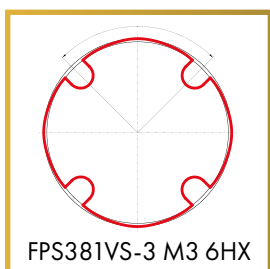

FPS381VS-3 M3 6HX

Раскатчик FPS-VS

Для $\varnothing \geq 3$ мм, с большими формообразующими лепестками, предназначенными для поступательного движения материалов с низким коэффициентом удлинения. С износостойким покрытием DC "VS", улучшающим тепловые и химические свойства. Для конструкционных сталей, углеродистых сталей, легированных сталей и т. д.

Thread former FPS-VS

For $\varnothing \geq 3$ mm, with large forming lobes designed for a progressive flow of materials with low elongation coefficient. With DC "VS" wear-protective coating with thermal and chemical properties. For structural steels, carbon steels, alloy steels, etc.

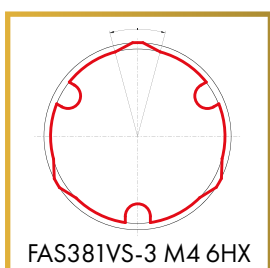

FAS381VS-3 M4 6HX

Раскатчик FAS-VS

Для $\varnothing \geq 3$ мм, с заостренными формообразующими лепестками, предназначенными для быстрого движения вязких материалов с высоким коэффициентом удлинения. С износостойким покрытием DC "VS" с отличными смазочными и скользящими свойствами. Для нержавеющей стали, чистой меди и т. д.

Thread former FAS-VS

For $\varnothing \geq 3$ mm, with pointed forming lobes designed for a fast flow of tough materials with high elongation coefficient. With DC "VS" wear-protective coating with excellent lubrication and sliding properties. For stainless steels, pure copper, etc.



Смазочные канавки от $\varnothing 3$ мм

Смазка будет направляться на поверхность инструмента, которая непосредственно соприкасается с материалом.

Lubrication grooves from $\varnothing 3$ mm

Lubricant will be guided to the surface of the tool which is directly in contact with the material.



Без смазочных канавок

Особенно рекомендуется для формования мягких материалов и сквозных отверстий в тонких деталях (например, для обработки листового металла).

Without lubrication grooves

Especially recommended for forming soft materials and for through holes in thin parts (e.g. for sheet metal working).



С внутренним подводом СОЖ

Настоятельно рекомендуется для более глубоких резьб и для горизонтальной обработки.

With internal coolant supply

Highly recommended for deeper threads and for horizontal working.

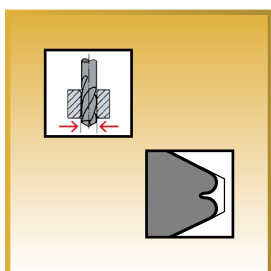

Правильный профиль резьбы

Для того, чтобы сформировать резьбу в соответствии с нормой требуется очень точное отверстие под резьбу. Для материалов с очень высоким коэффициентом удлинения и глубиной резьбы $> 2 \times D$ рекомендуется увеличить диаметр отверстия на 0.02 - 0.05 мм.

Correct thread profile

Accurate core hole is required in order to form a thread according to the norm. For materials with a very high elongation coefficient and threading depth $> 2 \times D$, we recommend increasing the core hole \varnothing by 0.02 to 0.05 mm.

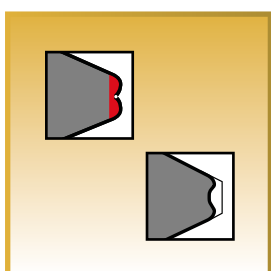

Неправильный профиль резьбы

Слишком высокий профиль из-за недостаточного диаметра отверстия под резьбу. Потребуется увеличение крутящего момента. Неполный профиль вызван слишком большим диаметром отверстия.

Incorrect thread profile

Too big profile due to the too small core hole diameter. The required torque is higher.

Incomplete profile caused by the core hole diameter being too big.

КОДИРОВКА – CODIFICATION

DC Раскатники

DC Thread formers

Пример - Example



Форма стандартного полигона $\lt; \varnothing 3\text{мм}$	Standard polygon form $\lt; \varnothing 3\text{ mm}$	FS							
Форма пассивного полигона >math>\ge \varnothing 3\text{мм}</math>	Passive polygon form >math>\ge \varnothing 3\text{ mm}</math>	FPS							
Форма активного полигона >math>\ge \varnothing 3\text{мм}</math>	Active polygon form >math>\ge \varnothing 3\text{ mm}</math>	FAS							
Специальное исполнение	Special execution		3						
Усиленный хвостовик по DIN	DIN long - reinforced shank			3					
Утонченный хвостовик по DIN	DIN long - reduced shank			4					
Сверхдлинный усиленный хвостовик по DIN	DIN extra-long - reinforced shank			5					
Сверхдлинный утонченный хвостовик по DIN	DIN extra-long - reduced shank			6					
Раскатник	Thread former				8				
Без канавок для подвода СОЖ	Without lubrication grooves					0			
С канавками для подвода СОЖ	With lubrication grooves					1			
Внутренний подвод СОЖ с радиальным выходом	Internal coolant with radial outflow					4			
Износостойкое покрытие	VS wear-protective coating, general						VS		
Покрытие DLC	DLC-coating						DL		
Заходная часть 2 - 3 нитки	2 - 3 chamfered threads							-3	
Заходная часть 1.5 - 2 нитки	1.5 - 2 chamfered threads							-5	

ПИКТОГРАММЫ — PICTOGRAPHS



Для групп материалов согласно таблице .
For material groups as per application chart

12	
1.0037	Si37-2 (S235JR)
1.0050	St50-2 (E295)
1.0060	St60-2 (E335)
1.5919	15CrNi6
1.7131	16MnCr5

22	
1.4301	X5CrNi18-10
1.4406	X2CrNiMoN17-12-2
1.4435	X2CrNiMo18-14-3
1.4541	X6CrNiTi18-10
1.4571	X6CrNiMoTi17-12-2

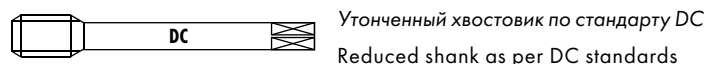
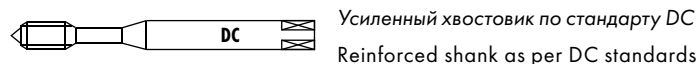

Сверхдлинный
Extra-long



Порошковая быстрорежущая сталь HSSE-PM
HSSE-PM



Раскатник
Thread former



Раскатник с канавками подвода СОЖ
Thread former with lubrication grooves



Внутренний подвод СОЖ с фронтальным выходом
Internal coolant with frontal outflow



Внутренний подвод сож с радиальным выходом, новый 45°
Переход на новую версию в процессе подготовки
Internal coolant with radial outflow, new 45°
Change to new version in progress



Диаметр отверстия под резьбу
Core hole diameter



Левая резьба
Left-hand thread



Заходная часть 2 - 3 нитки, форма C
2 - 3 chamfered threads, lead form C



Заходная часть 1.5 - 2 нитки, форма E
1.5 - 2 chamfered threads, lead form E



Класс точности ISO 2 6HX
Tolerance class ISO 2 6HX



Класс точности ISO 3 6GX
Tolerance class ISO 3 6GX



Сквозные/глухие отверстия < 1 x D
Through / blind holes < 1 x D



Сквозные/глухие отверстия < 1.5 x D
Through / blind holes < 1.5 x D



Сквозные/глухие отверстия < 2.5 x D
Through / blind holes < 2.5 x D



Сквозные/глухие отверстия > 2.5 x D
Through / blind holes > 2.5 x D



Сквозные/глухие отверстия < 3 x D
Through / blind holes < 3 x D



Покрытие DLC
DLC-coating



DC "VS" износостойкое покрытие общего назначения
DC "VS" wear-protective coating for general use



Для скоростного нарезания
For Rigid Tapping



Для классического нарезания резьбы
For Classic Tapping



Складская позиция
Stock item



Доступно в короткие сроки
Available at short notice



Доступно пока есть на складе
Available from stock, while stock lasts

ТАБЛИЦА ПРИМЕНЕНИЯ — APPLICATION CHART

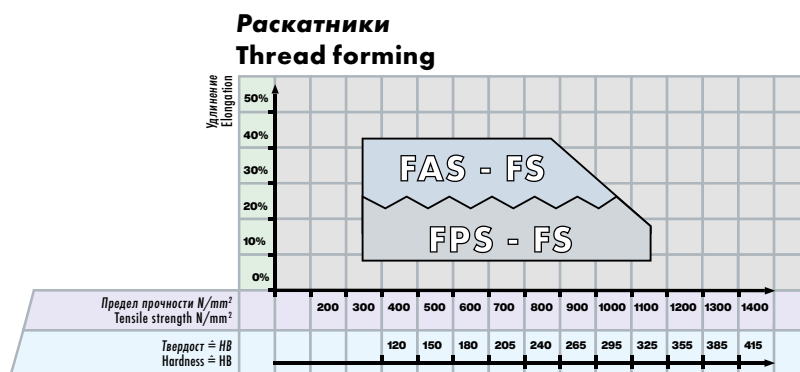

DC Классификация материалов

DC Material classification

Группы материалов Material groups	Обозначение материалов	Material designation	Твердость Hardness (HB)	Предел прочности Tensile strength Rm (N/mm ²)	Удлинение Elongation A (%)
10 Стали Steels	11	Легко обрабатываемые стали	< 200	< 700	< 10
	12	Структурные, цементуемые стали	< 200	< 700	< 30
	13	Углеродистые стали	< 300	< 1000	< 20
	14	Легированные стали < 850 N/mm ²	< 250	< 850	< 30
	15	Легированные стали закал./отп. > 850 - < 1150 N/mm ²	> 250	> 850	< 30
	16	Высокопрочные легированные стали ≤ 44 HRC	> 250	> 850	< 12
	17	Закалённые легированные стали > 44 - ≤ 54 HRC	> 410	> 1400	< 2
	18	Закалённые легированные стали > 54 - ≤ 63 HRC	> 560	> 1980	< 2
20 Нержавеющие стали Stainless steels	21	Легко обрабатываемые нержавеющие стали	< 250	< 850	< 25
	22	Аустенитные нержавеющие стали	< 250	< 850	> 20
	23	Ферритные и мартенситные < 850 N/mm ²	< 250	< 850	> 20
	24	Ферритные и мартенситные > 850 - < 1150 N/mm ²	> 250	> 850	> 15
30 Чугун Cast iron	31	Чугун	< 250	< 850	< 10
	32	Высокопрочные и ковкий чугун	< 250	< 850	> 10
40 Титан Titanium	41	Чистый титан	< 250	< 850	> 20
	42	Титановые сплавы	> 250	> 850	< 20
50 Никель Nickel	51	Никелевые сплавы 1 ≤ 850 N/mm ²	< 250	< 850	> 25
	52	Никелевые сплавы 2 > 850 - ≤ 1150 N/mm ²	> 250	> 850	< 25
	53	Никелевые сплавы 3 > 1150 - ≤ 1600 N/mm ²	> 340	> 1150	< 20
60 Медь Copper	61	Медь чистая (электрохимическая)	< 120	< 400	> 12
	62	Короткостружечная латунь, фосфористая бронза	< 200	< 700	< 12
	63	Длинностружечная латунь	< 200	< 700	> 12
	64	бессвинцовая латунь	< 220	< 700	> 15
70 Алюминий Магний Aluminium Magnesium	71	Алюминий чистый	< 100	< 350	> 15
	72	Алюминиевые сплавы Si < 1.5 %	< 150	< 500	> 15
	73	Алюминиевые сплавы Si > 1.5 % - < 10 %	< 120	< 400	< 15
	74	Алюминиевые сплавы Si > 10 %, магниевые сплавы	< 120	< 400	< 10
80 Пластики Plastic compounds	81	Термопластики	-	-	-
	82	Дюропластики	-	-	-
	83	Пластики армированные стекловолокном	-	-	-
90 Драгоценные металлы Precious metals	91	Желтое золото	-	-	-
	92	Красное золото	-	-	-
	93	Белое золото	-	-	-
	94	Серебро	-	-	-

Оптимально с маслом
Optimal with cutting oil

Допустимо с маслом
Suitable with cutting oil

Оптимально с эмульсией
Optimal with emulsion

Допустимо с эмульсией
Suitable with emulsion

РАСКАТНИКИ — THREAD FORMING

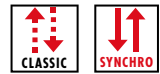

Со страницы:
From page:

M
MF
UNC
UNF
G

FS		FPS					FAS		
254	255	256	256	256	256	258	259	259	260
		NEW	NEW						

FS.80VS	FS.80DL	FPS.80DL	FPS.81DL	FPS.80VS	FPS.81VS	FPS.84VS	FAS.80VS	FAS.81VS	FAS.84VS

V_c
(m/min)
Guide Line
Ø 1 - 2.8 mm Ø 2.8 - 20 mm

11	12 - 20	20 - 40										11
12	12 - 20	20 - 40										12
13	12 - 20	20 - 30										13
14	12 - 20	20 - 30										14
15	6 - 12	10 - 15										15
16												16
17												17
18												18
21	12 - 20	10 - 20										21
22	6 - 12	10 - 15										22
23	6 - 12	6 - 12										23
24	6 - 12	6 - 12										24
31												31
32												32
41	12 - 20	10 - 20										41
42												42
51	6 - 12	10 - 15										51
52												52
53												53
61	12 - 20	10 - 20										61
62												62
63	12 - 20	20 - 30										63
64	12 - 20	20 - 30										64
71	12 - 20	20 - 40										71
72	12 - 20	20 - 40										72
73	12 - 20	20 - 40										73
74												74
81												81
82												82
83												83
91	12 - 20	20 - 40										91
92	12 - 20	20 - 40										92
93	12 - 20	20 - 40										93
94	12 - 20	20 - 40										94

A Оптимально с воздухом
Optimal with air

A Допустимо с воздухом
Suitable with air









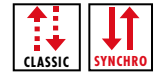













Ограниченное применение
Limited

Указаны ориентировочные значения.
The indicated values are a guideline.



					FS		FPS	
Характеристики Characteristics								
Тип отверстия Hole type								
					FS380VS-5 FS380VS-3	FS380DL-5 FS380DL-3	FPS380DL-3 FPS381DL-3	FPS380VS-3 FPS381VS-3
M	6HX	ISO DIN 13	Длинный по DIN DIN long	~DIN 2174	254	255	256	256
M	6GX	ISO DIN 13	Длинный по DIN DIN long	~DIN 2174	254	255		256
M	6HX	ISO DIN 13	Особо длинный Extra-long	DC				
MF	6HX	ISO DIN 13	Длинный по DIN DIN long	~DIN 2174				262
UNC	2BX	ASME B1.1	Длинный по DIN DIN long	~DIN 2184-1	263			263
UNF	2BX	ASME B1.1	Длинный по DIN DIN long	~DIN 2184-1	264			264
								FPS481VS-3
M	6HX	ISO DIN 13	Длинный по DIN DIN long	~DIN 2174				257
M	6GX	ISO DIN 13	Длинный по DIN DIN long	~DIN 2174				
M	6HX	ISO DIN 13	Особо длинный Extra-long	DC				
MF	6HX	ISO DIN 13	Длинный по DIN DIN long	~DIN 2174				262
UNC	2BX	ASME B1.1	Длинный по DIN DIN long	~DIN 2184-1				
UNF	2BX	ASME B1.1	Длинный по DIN DIN long	~DIN 2184-1				
G (BSP)		DIN EN ISO 228	Длинный по DIN DIN long	~DIN 2189				265



FPS			FAS			
 VS	 VS	 VS	 	 VS	 VS	 VS
			 			
						
FPS384VS-3	FPS581VS-3	FPS584VS-3	FAS380VS-3 FAS381VS-3	FAS384VS-3	FAS581VS-3	FAS584VS-3
258			259	260		
			259			
	257	258			261	261
			262			
			263			
			264			
FPS484VS-3	FPS681VS-3	FPS684VS-3	FAS481VS-3	FAS484VS-3	FAS681VS-3	FAS684VS-3
258			259	260		
			259			
	257	258			261	261
			262			
			265			

FS FORMING

FS380VS-5

11 12 13 14
21
FS380VS-3

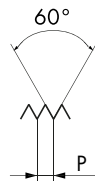
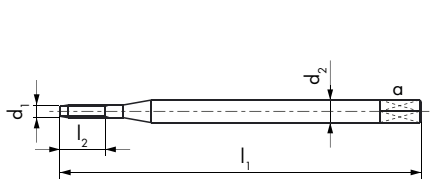
11 12 13 14
21
FS380VS-5
FS380VS-3
FS380VS-3
FS380VS-3

6HX
6HX
6HX
6GX

$\emptyset d_1$ M	P mm	l_1 mm	l_2 mm	d_2 mm	a mm	$\frac{4HX}{6HX}$ Tol.
1	0.25	40	3	2.5		0.88 +0.02
1.2	0.25	40	3.6	2.5		1.08 +0.02
1.4	0.3	40	4.2	2.5		1.25 +0.02
1.6	0.35	40	4.8	2.5		1.45 +0.02
1.7	0.35	40	5.1	2.5		1.55 +0.02
1.8	0.35	40	5.4	2.5		1.65 +0.02
2	0.4	45	8	2.8	2.1	1.8 +0.02
2.5	0.45	50	10	2.8	2.1	2.3 +0.02
2.6	0.45	50	10	2.8	2.1	2.4 +0.02

ID	ID	ID	ID	6H + mm
● 157171	● 173452			
● 157172	● 173455			
● 157173	● 173458			
● 157174	● 169779			
	● 169782			
● 157175	● 169785			
		● 157176	● 157180	0.019
		● 157178	● 157181	0.020
		● 157179		

≤M1.5 **4HX**

FS FORMING

FS380DL-5

FS380DL-3

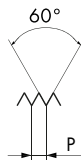
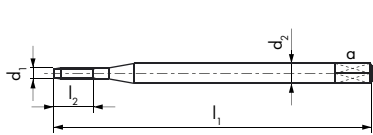
FS380DL-5
FS380DL-3
FS380DL-3
FS380DL-3

6HX
6HX
6HX
6GX

$\emptyset d_1$ M	P mm	l_1 mm	l_2 mm	d_2 mm	a mm	4HX Tol. 6HX	ID	ID	ID	ID	6H + mm
1	0.25	40	3	2.5		0.88 +0.02	● 172839	● 173461			
1.2	0.25	40	3.6	2.5		1.08 +0.02	● 172840	● 173464			
1.4	0.3	40	4.2	2.5		1.25 +0.02	● 172841	● 173467			
1.6	0.35	40	4.8	2.5		1.45 +0.02	● 170585	● 170916			
1.7	0.35	40	5.1	2.5		1.55 +0.02		● 172843			
1.8	0.35	40	5.4	2.5		1.65 +0.02	● 172842	● 172844			
2	0.4	45	8	2.8	2.1	1.8 +0.02			● 158814	● 172849	0.019
2.5	0.45	50	10	2.8	2.1	2.3 +0.02			● 172845	● 173246	0.020
2.6	0.45	50	10	2.8	2.1	2.4 +0.02			● 172846		

≤M1.5 4HX

FPS FORMING

FPS380DL-3			63 64 71 72 73 91 92 94
FPS381DL-3			63 64 71 72 73 91 92 94
FPS380VS-3			11 12 13 14
FPS381VS-3			11 12 13 14 15

FPS380DL-3 FPS381DL-3 FPS380VS-3 FPS381VS-3

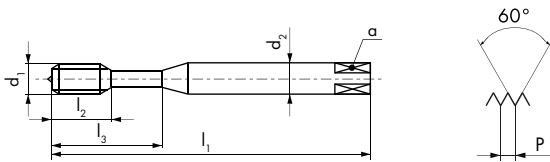

2.5 x P	2.5 x P	2.5 x P	2.5 x P
6HX	6HX	6HX	6HX

ϕd_1 M	P mm	l_1 mm	l_2 mm	l_3 mm	d_2 mm	a mm	6HX Tol.
3	0.5	56	12	18	3.5	2.7	2.8 +0.03
3.5	0.6	56	13	20	4	3	3.25 +0.03
4	0.7	63	14	21	4.5	3.4	3.7 +0.03
5	0.8	70	15	25	6	4.9	4.65 +0.03
6	1	80	17	30	6	4.9	5.55 +0.05
8	1.25	90	20	35	8	6.2	7.4 +0.05
10	1.5	100	22	39	10	8	9.3 +0.05

ID	ID	ID	ID
● 170553	● 182038	● 166614	● 166616
● 175347	● 182623	● 166620	● 166622
● 170554	● 182039	● 166627	● 166629
● 182619	● 178343	● 166635	● 166637
● 182620	● 171112	● 166644	● 166646
● 182621	● 179144	● 166654	● 166656
● 182622	● 171113	● 166664	● 166666

6GX 6GX

ϕd_1 M	P mm	l_1 mm	l_2 mm	l_3 mm	d_2 mm	a mm	6HX Tol.
3	0.5	56	12	18	3.5	2.7	2.8 +0.03
3.5	0.6	56	13	20	4	3	3.25 +0.03
4	0.7	63	14	21	4.5	3.4	3.7 +0.03
5	0.8	70	15	25	6	4.9	4.65 +0.03
6	1	80	17	30	6	4.9	5.55 +0.05
8	1.25	90	20	35	8	6.2	7.4 +0.05
10	1.5	100	22	39	10	8	9.3 +0.05

ID	6H + mm	ID	6H + mm
● 166697	0.020	● 166617	0.020
● 166687	0.021	● 166623	0.021
● 166688	0.022	● 166630	0.022
● 166689	0.024	● 166638	0.024
● 166686	0.026	● 166647	0.026
● 166740	0.028	● 166657	0.028
● 166739	0.032	● 166667	0.032

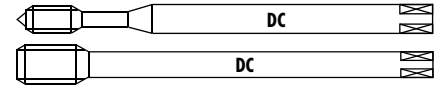

FPS FORMING

FPS481VS-3

 11 12 13 14
15
FPS581VS-3

 11 12 13 14
15
FPS681VS-3

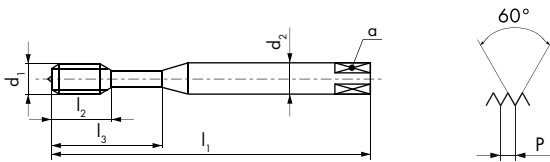
 11 12 13 14
15
FPS481VS-3
FPS581VS-3
FPS681VS-3

6HX
6HX
6HX

$\emptyset d_1$ M	P mm	l_1 mm	l_2 mm	d_2 mm	a mm	6HX Tol.
12	1.75	110	24	9	7	11.2 +0.05
14	2	110	28	11	9	13.1 +0.05
16	2	110	30	12	9	15.1 +0.05
20	2.5	140	36	16	12	18.85 +0.05

ID

- 166673
- 166678
- 166683
- 168713

$\emptyset d_1$ M	P mm	l_1 mm	l_2 mm	l_3 mm	d_2 mm	a mm	6HX Tol.
3	0.5	100	12	18	3.5	2.7	2.8 +0.03
4	0.7	125	14	21	4.5	3.4	3.7 +0.03
5	0.8	140	15	25	6	4.9	4.65 +0.03
6	1	160	17	30	6	4.9	5.55 +0.05
8	1.25	180	20	35	8	6.2	7.4 +0.05
10	1.5	200	22	39	10	8	9.3 +0.05
12	1.75	224	24		9	7	11.2 +0.05

ID
ID

- 172824
- 172826
- 172828
- 172830
- 172832
- 172834
- 172836

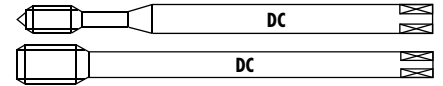
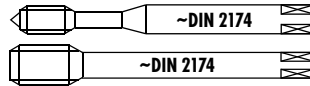

FPS FORMING

FPS384VS-3			VS	11/12/13/14 15
FPS484VS-3			VS	11/12/13/14 15
FPS584VS-3			EL VS	11/12/13/14 15
FPS684VS-3			EL VS	11/12/13/14 15

FPS384VS-3 FPS484VS-3 FPS584VS-3 FPS684VS-3

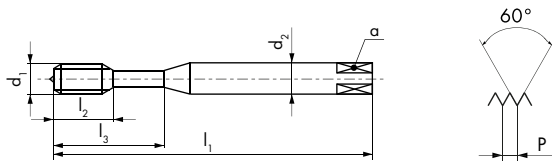

$\varnothing d_1$ M	P mm	l_1 mm	l_2 mm	l_3 mm	d_2 mm	a mm	6HX Tol.
3	0.5	56	12	18	3.5	2.7	2.8 +0.03
4	0.7	63	14	21	4.5	3.4	3.7 +0.03
5	0.8	70	15	25	6	4.9	4.65 +0.03
6	1	80	17	30	6	4.9	5.55 +0.05
8	1.25	90	20	35	8	6.2	7.4 +0.05
10	1.5	100	22	39	10	8	9.3 +0.05
12	1.75	110	24		9	7	11.2 +0.05
14	2	110	28		11	9	13.1 +0.05
16	2	110	30		12	9	15.1 +0.05

ID	ID
● 166737	
● 166738	
● 166640	
● 166650	
● 166660	
● 166670	
	● 166675
	● 166680
	● 166685

$\varnothing d_1$ M	P mm	l_1 mm	l_2 mm	l_3 mm	d_2 mm	a mm	6HX Tol.
3	0.5	100	12	18	3.5	2.7	2.8 +0.03
4	0.7	125	14	21	4.5	3.4	3.7 +0.03
5	0.8	140	15	25	6	4.9	4.65 +0.03
6	1	160	17	30	6	4.9	5.55 +0.05
8	1.25	180	20	35	8	6.2	7.4 +0.05
10	1.5	200	22	39	10	8	9.3 +0.05
12	1.75	224	24		9	7	11.2 +0.05

ID	ID
	● 172763
	● 172766
	● 172769
	● 172772
	● 172775
	● 172778
	● 172781

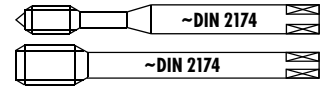

FAS FORMING

FAS380VS-3

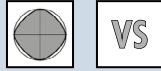

VS



FAS381VS-3

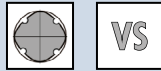

VS



FAS481VS-3



VS



FAS380VS-3



FAS381VS-3



FAS481VS-3

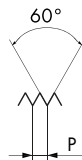
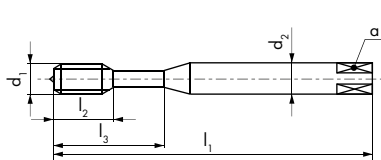

6HX

6HX

6HX

$\emptyset d_1$ M	P mm	l_1 mm	l_2 mm	l_3 mm	d_2 mm	a mm	6HX Tol.
3	0.5	56	12	18	3.5	2.7	2.8 +0.03
3.5	0.6	56	13	20	4	3	3.25 +0.03
4	0.7	63	14	21	4.5	3.4	3.7 +0.03
5	0.8	70	15	25	6	4.9	4.65 +0.03
6	1	80	17	30	6	4.9	5.55 +0.05
8	1.25	90	20	35	8	6.2	7.4 +0.05
10	1.5	100	22	39	10	8	9.3 +0.05
12	1.75	110	24		9	7	11.2 +0.05
14	2	110	28		11	9	13.1 +0.05
16	2	110	30		12	9	15.1 +0.05
20	2.5	140	36		16	12	18.85 +0.05

ID

ID

ID

● 170603	● 166612	
● 170605	● 166618	
● 170607	● 166624	
● 170609	● 166632	
● 170611	● 166641	
● 170616	● 166651	
● 170618	● 166661	
		● 166671
		● 166676
		● 166681
		● 168711

6GX

6GX

$\emptyset d_1$ M	P mm	l_1 mm	l_2 mm	l_3 mm	d_2 mm	a mm	6HX Tol.
3	0.5	56	12	18	3.5	2.7	2.8 +0.03
3.5	0.6	56	13	20	4	3	3.25 +0.03
4	0.7	63	14	21	4.5	3.4	3.7 +0.03
5	0.8	70	15	25	6	4.9	4.65 +0.03
6	1	80	17	30	6	4.9	5.55 +0.05
8	1.25	90	20	35	8	6.2	7.4 +0.05
10	1.5	100	22	39	10	8	9.3 +0.05
12	1.75	110	24		9	7	11.2 +0.05
14	2	110	28		11	9	13.1 +0.05
16	2	110	30		12	9	15.1 +0.05

ID

6H
+ mm

ID

6H
+ mm

● 166703	0.020		
● 166704	0.021		
● 166705	0.022		
● 166706	0.024		
● 166707	0.026		
● 166708	0.028		
● 166709	0.032		
		● 166710	0.034
		★ 166711	0.038
		● 166712	0.038

FAS FORMING

FAS384VS-3



FAS484VS-3



FAS384VS-3

FAS484VS-3

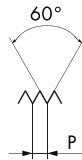
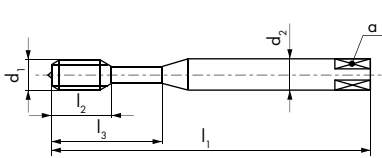

$\emptyset d_1$ M	P mm	l_1 mm	l_2 mm	l_3 mm	d_2 mm	a mm	6HX Tol.
3	0.5	56	12	18	3.5	2.7	2.8 +0.03
4	0.7	63	14	21	4.5	3.4	3.7 +0.03
5	0.8	70	15	25	6	4.9	4.65 +0.03
6	1	80	17	30	6	4.9	5.55 +0.05
8	1.25	90	20	35	8	6.2	7.4 +0.05
10	1.5	100	22	39	10	8	9.3 +0.05
12	1.75	110	24		9	7	11.2 +0.05
14	2	110	28		11	9	13.1 +0.05
16	2	110	30		12	9	15.1 +0.05

ID

ID

● 166741

● 166742

● 166690

● 166691

● 166692

● 166693

● 166694

● 166695

● 166696

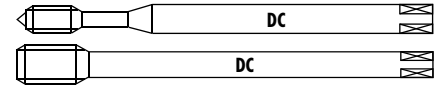

FAS FORMING

FAS581VS-3



FAS681VS-3



FAS584VS-3



FAS684VS-3



FAS581VS-3

FAS681VS-3

FAS584VS-3

FAS684VS-3

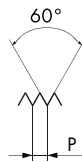
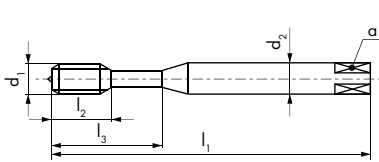

$\emptyset d_1$ M	P mm	l_1 mm	l_2 mm	l_3 mm	d_2 mm	a mm	6HX Tol.
3	0.5	100	12	18	3.5	2.7	2.8 +0.03
4	0.7	125	14	21	4.5	3.4	3.7 +0.03
5	0.8	140	15	25	6	4.9	4.65 +0.03
6	1	160	17	30	6	4.9	5.55 +0.05
8	1.25	180	20	35	8	6.2	7.4 +0.05
10	1.5	200	22	39	10	8	9.3 +0.05
12	1.75	224	24		9	7	11.2 +0.05

ID	ID	ID	ID
● 172784		● 172805	
● 172787		● 172808	
● 172790		● 172811	
● 172793		● 172814	
● 172796		● 172817	
● 172799		● 172820	
	● 172802		● 172822

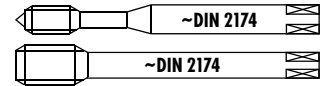

FPS FAS		FORMING						FPS381VS-3	FPS481VS-3	FAS381VS-3	FAS481VS-3
FPS381VS-3		VS	11	12	13	14	15				
FPS481VS-3		VS	11	12	13	14	15				
FAS381VS-3		VS	21	22	23	24	41	51	61		
FAS481VS-3		VS	21	22	23	24	41	51	61		
$\varnothing d_1$	P	l_1	l_2	l_3	d_2	a	6HX Tol.	ID	ID	ID	ID
MF	mm	mm	mm	mm	mm	mm					
4	0.5	63	14	21	4.5	3.4	3.8 +0.03	● 166631		● 166625	
5	0.5	70	15	25	6	4.9	4.8 +0.03	● 166639		● 166633	
6	0.5	80	17	30	6	4.9	5.8 +0.03	● 166699		● 166698	
6	0.75	80	17	30	6	4.9	5.65 +0.03	● 166649		● 166642	
8	0.75	90	20	35	8	6.2	7.65 +0.03	● 166702		● 166700	
8	1	90	20	35	8	6.2	7.55 +0.05	● 166659		● 166652	
10	1	100	22	39	10	8	9.55 +0.05	● 166669		● 166662	
12	1	100	19		9	7	11.55 +0.05		● 166674		● 166672
14	1.5	100	24		11	9	13.3 +0.05		● 166679		● 166677
16	1.5	100	26		12	9	15.3 +0.05		● 166684		● 166682

FS FPS FAS FORMING										FS380VS-3	FPS381VS-3	FAS381VS-3
FS380VS-3 VS												
FPS381VS-3 VS												
FAS381VS-3 VS												
ϕ_1 UNC	P TPI	d_1 mm	l_1 mm	l_2 mm	l_3 mm	d_2 mm	a mm	ϕ 2BX	Tol.	ID	ID	ID
2	56	2.18	45	9		2.8	2.1	1.95	+0.02	● 157285		
4	40	2.84	56	12	18	3.5	2.7	2.55	+0.03		● 170063	● 170065
6	32	3.5	56	13	20	4	3	3.15	+0.03		● 166713	● 166725
8	32	4.16	63	14	21	4.5	3.4	3.8	+0.03		● 166714	● 166726
10	24	4.82	70	15	25	6	4.9	4.35	+0.05		● 166715	● 166727
1/4	20	6.35	80	17	30	7	5.5	5.75	+0.05		● 166716	● 166728

FS FPS FORMING FAS

	FS380VS-5	FPS381VS-3	FAS381VS-3																																													
FS380VS-5 VS																																																
FPS381VS-3 VS																																																
FAS381VS-3 VS																																																
	 2BX	 2BX	 2BX																																													
<table border="1"> <thead> <tr> <th>Ø" d₁ UNF</th> <th>P TPI</th> <th>d₁ mm</th> <th>l₁ mm</th> <th>l₂ mm</th> <th>l₃ mm</th> <th>d₂ mm</th> <th>a mm</th> <th>Tol.</th> </tr> </thead> <tbody> <tr> <td>0</td> <td>80</td> <td>1.52</td> <td>40</td> <td>4.6</td> <td></td> <td>2.5</td> <td>1.37</td> <td>+0.02</td> </tr> <tr> <td>10</td> <td>32</td> <td>4.82</td> <td>70</td> <td>15</td> <td>25</td> <td>6</td> <td>4.9</td> <td>+0.03</td> </tr> <tr> <td>1/4</td> <td>28</td> <td>6.35</td> <td>80</td> <td>17</td> <td>30</td> <td>7</td> <td>5.5</td> <td>+0.05</td> </tr> <tr> <td>5/16</td> <td>24</td> <td>7.93</td> <td>90</td> <td>20</td> <td>35</td> <td>8</td> <td>6.2</td> <td>+0.05</td> </tr> </tbody> </table>	Ø" d ₁ UNF	P TPI	d ₁ mm	l ₁ mm	l ₂ mm	l ₃ mm	d ₂ mm	a mm	Tol.	0	80	1.52	40	4.6		2.5	1.37	+0.02	10	32	4.82	70	15	25	6	4.9	+0.03	1/4	28	6.35	80	17	30	7	5.5	+0.05	5/16	24	7.93	90	20	35	8	6.2	+0.05	ID <ul style="list-style-type: none"> 161498 	ID <ul style="list-style-type: none"> 166718 166719 166720 	ID <ul style="list-style-type: none"> 166730 166731 166732
Ø" d ₁ UNF	P TPI	d ₁ mm	l ₁ mm	l ₂ mm	l ₃ mm	d ₂ mm	a mm	Tol.																																								
0	80	1.52	40	4.6		2.5	1.37	+0.02																																								
10	32	4.82	70	15	25	6	4.9	+0.03																																								
1/4	28	6.35	80	17	30	7	5.5	+0.05																																								
5/16	24	7.93	90	20	35	8	6.2	+0.05																																								



FPS FAS				FPS481VS-3		FAS481VS-3			
FPS481VS-3 VS									
FAS481VS-3 VS									
$\frac{\text{Ø}'' d_1}{G}$	P TPI	d_1 mm	l_1 mm	l_2 mm	d_2 mm	a mm	Tol.	ID	ID
1/8	28	9.72	90	22	7	5.5	9.25 +0.05	● 166721	● 166733
1/4	19	13.15	100	20	11	9	12.5 +0.05	● 166722	● 166734
3/8	19	16.66	100	20	12	9	16 +0.05	● 166723	● 166735
1/2	14	20.95	125	22	16	12	20 +0.05	● 166724	● 166736

ПЛАШКИ СО СПИРАЛЬНОЙ ПОДТОЧКОЙ

Спиральная подточка облегчает отведение стружки перед плашкой и снижает крутящий момент резания. Исключается пакетирование стружки в стружечных отверстиях. Это позволяет получать лучшее качество резьбовой поверхности и увеличить стойкость плашки.

Плашки для машинного использования следует заказывать со спиральной подточкой.



DIES WITH SPIRAL ENTRY

A spiral entry results in a free flow of chips ahead of the die and a reduction in the cutting torque. Blocking of the clearance holes by chips is avoided. This results in an improved surface finish on the cut threads and a longer die life.

Hence dies for machine use must be ordered with spiral entry.

ВЫСОКОПРОИЗВОДИТЕЛЬНЫЕ РЕЗЬБОВЫЕ ПЛАШКИ

HIGH PERFORMANCE THREAD CUTTING DIES

N5110/N5120



спиральная подточка от $\varnothing 3$ mm
with spiral entry from $\varnothing 3$ mm

Круглые плашки из HSS, по стандартам DIN EN

для машинного и ручного использования

- Для обработки сталей до 800 Н/мм²
- Различные исполнения для обработки широкого диапазона материалов

Round dies in HSS, as per DIN EN standards

for machine and manual use

- For machining steels up to 800 N/mm²
- Different versions for cutting a wide range of materials

Z5120



спиральная подточка от $\varnothing 2$ mm
with spiral entry from $\varnothing 2$ mm

Круглые плашки из HSSE, по стандартам DIN EN

- Мелкая стружка из-за большего количества стружечных отверстий и, следовательно, большего количества режущих кромок, а также увеличения заходной части до 2 x P
- Для обработки нержавеющей сталей, улучшаемых, цементуемых сталей и т.д. до 1'200 Н/мм² и короткостружечных сплавов алюминия

Round dies in HSSE, as per DIN EN standards

- Fine chips due to more clearance holes and thus more cutting edges, and the extension of the chamfer to 2 x P
- For machining stainless steels, heat-treatable steels, case-hardening steels etc. up to 1'200 N/mm² and short-chipping ALU alloys

Z5120 LL Long Life



спиральная подточка от $\varnothing 2$ mm
with spiral entry from $\varnothing 2$ mm

Круглые плашки из HSSE (ASP), по стандартам DIN EN

- Очень мелкая стружка из-за максимального количества стружечных отверстий и, следовательно, большего количества режущих кромок, а также увеличения заходной части до 2.25 x P
- Для производства крупных партий деталей
- Очень высокая стойкость плашек
- Для обработки нержавеющей сталей, улучшаемых, цементуемых сталей и т.д. до 1'200 Н/мм² и короткостружечных сплавов алюминия

Round dies in HSSE (ASP), as per DIN EN standards

- Very fine chips due to maximum number of clearance holes and thus still more cutting edges, and the extension of the chamfer to 2.25 x P
- For the processing of large series
- Exceptionally long die life
- For machining stainless steels, heat-treatable steels, case-hardening steels etc. up to 1'200 N/mm² and short-chipping ALU alloys

MS5120



спиральная подточка
with spiral entry

Круглые плашки из HSS, по стандартам DIN EN

- С увеличенными стружечными отверстиями для предотвращения скопления стружки
- Для обработки короткостружечной латуни

Round dies in HSS, as per DIN EN standards

- With enlarged clearance holes to prevent chips crowding
- For the machining of short-chipping brass

N5220 Z5220

MS5220



спиральная подточка
with spiral entry

Плашки для автоматов продольного точения, из HSS, с 2 отверстиями

- Область применения как указано для типов N5120, MS5120 и Z5120
- Преимущество: жесткость крепления плашки позволяет использовать большие скорости шпинделя и продляет срок её службы

Button dies for Swiss automatics, in HSS (Z = HSSE), with 2 securing holes

- Application area according to type N5120, MS5120 and Z5120
- Advantage: the low inertia of the die holder permits higher spindle speeds and extends die life

N5310



Шестигранные плашки из HSS, общие размеры согласно DIN 382

- Для повторного нарезания и восстановления поврежденных резьб или для нарезания резьбы в труднодоступных местах

Hexagon die nuts in HSS, general dimensions as per DIN 382

- For recutting and reclaiming damaged threads or for cutting threads in difficult locations

N5420



спиральная подточка от $\varnothing 3$ mm
with spiral entry from $\varnothing 3$ mm

Плашки конической формы из HSS

- Преимущество: улучшенный стружкоотвод и подача охлаждающей жидкости благодаря открытым стружечным отверстиям, даже при нарезании резьбы вплотную к уступам

Bell form type thread cutting dies in HSS

- Advantage: free chip flow and improved coolant supply thanks to the open clearance holes, even when cutting threads close to shoulders

ТАБЛИЦА ПРИМЕНЯЕМОСТИ ПЛАШЕК APPLICATION CHART FOR CUTTING DIES

Обозначение материала	Примеры ГОСТ	Ус м/мин (ориентир.)	Рекомендуемая смазка	Тип плашки	Передний угол
Стали общего назначения	Ст3сп, Ст5сп	8 - 12	Масло для нарезания резьбы	17 - 22°	N5...
Автоматные стали	A11, A15X	10 - 14	Масло для нарезания резьбы	17 - 22°	N5...
Стали цементируемые	Сталь 15, 20, 18ХГ	6 - 10	Масло для нарезания резьбы / Масло специальное	17 - 22°	Z5... / Z5... LL
Стали высококачественные	Сталь 45, 35ХГФ	5 - 8	Масло специальное	13 - 18°	Z5... / Z5... LL
Нержавеющие стали	12Х13, 14Х17Н2	4 - 6	Масло специальное	13 - 18°	Z5... / Z5... LL
Короткостружечная латунь	ЛЦ40С, ЛС59-1	20 - 30	Масло для нарезания резьбы	6 - 11°	MS5...
Длинностружечная латунь	Л63, Л80	12 - 18	Масло для нарезания резьбы	10 - 15°	N5...
Сплавы алюминия, короткая стружка	АК8М, АК12	8 - 12	Масло специальное, керосин	18 - 23°	Z5...
Чистый титан	BT1-0	5 - 8	Масло специальное	19 - 24°	Z5... / Z5... LL

Плашки специального исполнения с геометрией, адаптированной для серого чугуна, бессвинцовой латуни, бронзы, меди и длинностружечных алюминиевых сплавов.

Доступны плашки с покрытием. Цены и сроки поставки по запросу.

Material designation	Material Number	Cutting speed m/min (guide line)	Cutting fluid	Rake angle	Type of die
General engineering steels	St37-2, St50-2	8 - 12	Cutting oil	17 - 22°	N5...
Free-cutting steels	9SMn28, 9SMnPb28	10 - 14	Cutting oil	17 - 22°	N5...
Case hardening steels	C15, Ck15, 16MnCr5	6 - 10	Cutting oil / Special cutting oil	17 - 22°	Z5... / Z5... LL
Heat-treatable steels	C35Pb, C45	5 - 8	Cutting oil / Special cutting oil	13 - 18°	Z5... / Z5... LL
Stainless steels	X12CrMoS17, X12CrNiS188	4 - 6	Special cutting oil	13 - 18°	Z5... / Z5... LL
Short chip brass Ms 58	CuZn39Pb2, CuZn40Pb2	20 - 30	Cutting oil	6 - 11°	MS5...
Long chip brass Ms 60	CuZn20, CuZn37	12 - 18	Cutting oil	10 - 15°	N5...
Al-alloyed, short-chipping	GD-ALSi8Cu3, GD-ALSi12	8 - 12	Spezial cutting oil, Paraffin	18 - 23°	Z5...
Pure titanium	Ti2	5 - 8	Special cutting oil	19 - 24°	Z5... / Z5... LL

Cutting dies with specially adapted rake angle for grey cast iron, lead-free brass, bronze, gunmetal, copper and long-chipping aluminium alloys are available as special execution.

On request, we can also supply dies in a coated version. Price and delivery time on request.

ДОПУСКИ ДЛЯ РЕЗЬБ М И MF TOLERANCES FOR M AND MF THREADS

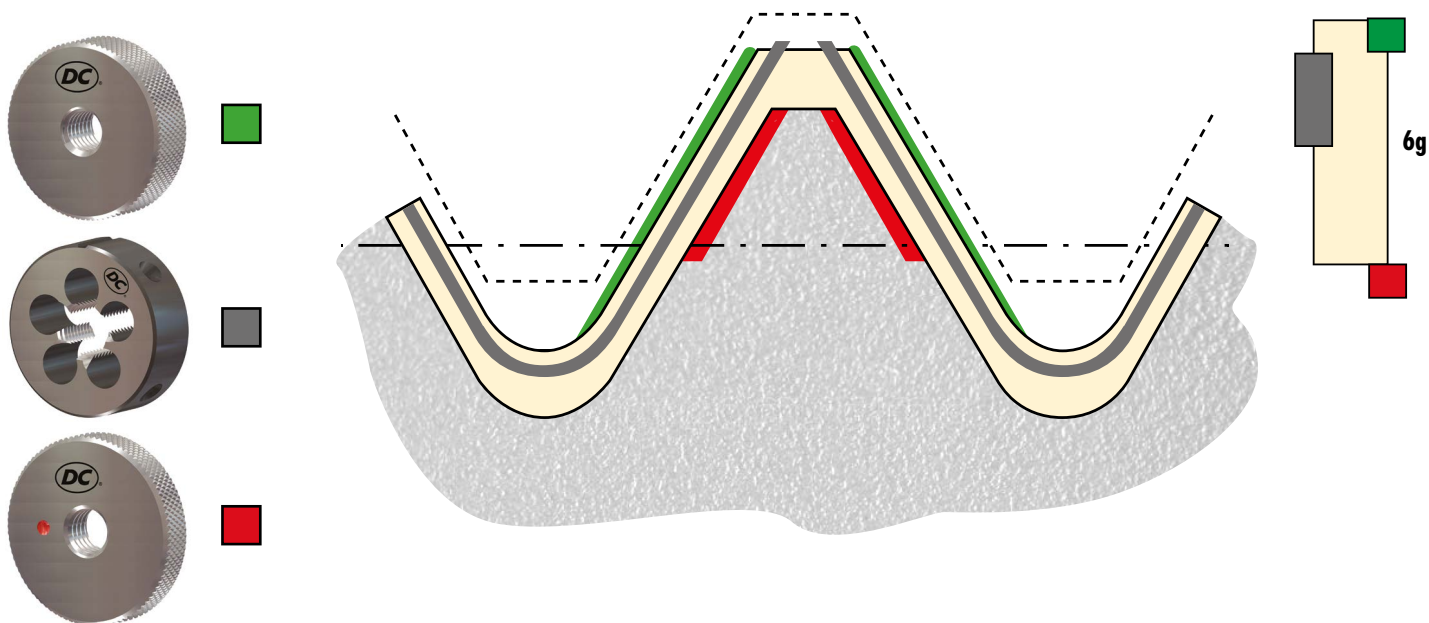

КОДИРОВКА – CODIFICATION



Пример

Z	51	20	LL	SP
---	----	----	----	----

Нормальные материалы	N
Латунь с короткой стружкой	MS
Вязкие материалы	Z
Круглые плашки*	
Плашки для автоматов продольного точения, с 2 крепежными отверстиями	51
Шестигранные плашки	52
Плашки конической формы	53
Твердый, форма В	54
Твердый, форма В, со спиральным входом	10
Долговечность - Высокая производительность умирает	20
Специальное исполнение	LL
	SP

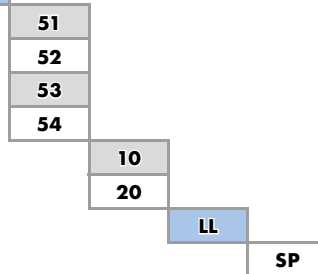

*Для производства используйте плашки со спиральной подточкой



Example

Z	51	20	LL	SP
---	----	----	----	----

Normal materials	N
Short chip brass	MS
Tough materials	Z
Round dies*	
Button dies for automatic lathes, with 2 securing holes	51
Hexagon die nuts	52
Bell form dies	53
Solid, form B	54
Solid, form B, with spiral entry	10
Long Life - High performance dies	20
Special execution	LL
	SP

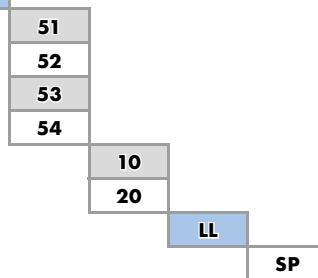

*For production, use dies with spiral entry.

Круглые плашки из HSS, по стандартам DIN EN

- DIN EN 22568: для резьб M, MF, UNC, UNF, UNEF, UN, UNS и W (BSW)
- ≈ DIN EN 22568: для американской трубной конической резьбы NPT по ASME B1.20.1 и NPTF по ANSI B1.20.3
- ≈ DIN EN 22568: для трапецеидальной резьбы TR по DIN 103
- DIN EN 24231: для резьбы G (BSP) по DIN EN ISO 228
- ≈ DIN EN 24230: для конической трубной резьбы Витворта BSPT (R) по DIN EN 10226, ISO 7-1
- ≈ DIN 40434 и DIN EN 22568: для трубной электротехнической резьбы PG по DIN 40430

Round dies in HSS, as per DIN EN standards

- DIN EN 22568: for M-, MF-, UNC-, UNF-, UNEF, UN-, UNS- and W (BSW) threads
- ≈ DIN EN 22568: for American standard taper pipe thread NPT as per ASME B1.20.1 and NPTF as per ANSI B1.20.3
- ≈ DIN EN 22568: for TR threads as per DIN 103
- DIN EN 24231: for G threads (BSP) as per DIN EN ISO 228
- ≈ DIN EN 24230: for Tapered Whitworth pipe thread R as per DIN EN 10226, ISO 7-1
- ≈ DIN 40434 and DIN EN 22568: for PG threads (steel conduit thread) as per DIN 40430



- N:** HSS, заходная часть 1.75 x P
- MS:** HSS, шлифованная, заходная часть 1.25 x P
- Z:** HSSE, азотированные от Ø 3 мм (P = 0.5 мм)
заходная часть 2 x P, спиральная подточка от Ø 2 мм
- Z-LL:** ASP, азотированные от Ø 3 мм (P = 0.5 мм),
заходная часть 2.25 x P, спиральная подточка от Ø 2 мм

- N:** HSS, chamfer length 1.75 x P
- MS:** HSS, lapped, chamfer length 1.25 x P
- Z:** HSSE, nitrided from Ø 3 mm (P = 0.5 mm),
chamfer length 2 x P, with spiral entry from Ø 2 mm
- Z-LL:** ASP, nitrided from Ø 3 mm (P = 0.5 mm), chamfer
length 2.25 x P, with spiral entry from Ø 2 mm





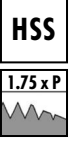
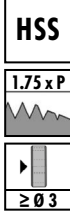













Указатель — Круглые плашки, плашки для Швейцарских автоматов, шестигранные и выгнутые
Directory — Round dies, button dies for Swiss automatics, hexagon die nuts and bell form dies

		N		MS	Z		N	Z
Характеристики Characteristics								
			$\geq \emptyset 3$	$\geq \emptyset 3$	$\geq \emptyset 2$	$\geq \emptyset 2$	$\geq \emptyset 3$	$\geq \emptyset 2$
					NI	NI		NI
								
Тип Type		N5110	N5120	MS5120	Z5120	Z5120LL	N5220	Z5220
M 6g	ISO DIN 13	272	272		273	273	286	286
M 6e	ISO DIN 13		272				286	
M 6g LH	ISO DIN 13		272					
MF 6g	ISO DIN 13	274	274 - 276		274 - 275		287	
MF 6e	ISO DIN 13		274					
MF 6g LH	ISO DIN 13		274 - 276					
UNC	ASME B1.1	277	277					
UNF	ASME B1.1	278	278					
UNEF	ASME B1.1		279					
UN	ASME B1.1		279					
UNS	ASME B1.1		279					
G (BSP)	DIN EN ISO 228		280	281	281			
G (BSP) LH	DIN EN ISO 228		280					
G (BSP) -0.1mm	DIN EN ISO 228			281				
R (BSPT)	DIN EN 10226		282					
NPT	ASME B1.20.1		283					
NPTF	ANSI B1.20.3		283					
PG	DIN 40430		284					
TR	DIN 103		284					
W (BSW)	BS 84		285					
W (BSW) LH	BS 84		285					

N	
	
	
N5310	N5420
288	289
288	
289	
289	

Пиктограммы - Pictographs















	Быстрорежущая сталь HSS
	Быстрорежущая сталь с кобальтом HSSE
	1.25 Заходная часть 1.25 нитки 1.25 chamfered threads
	1.75 Заходная часть 1.75 нитки 1.75 chamfered threads
	2 Заходная часть 2 нитки 2 chamfered threads
	Подчищающая фаска на диаметрах $\varnothing > 3$ mm Spiral entry from $\varnothing 3$ mm
	Подчищающая фаска с двух сторон на диаметрах $\varnothing > 3$ mm Spiral entry on both sides from $\varnothing 3$ mm
	Количество режущих кромок Number of flutes
	Диаметр прутка под плашку Turned diameters
	Азотированные ($d1 \geq 3$ mm, $P \geq 0.5$ mm) Nitrided ($d1 \geq 3$ mm, $P \geq 0.5$ mm)
	С 2 предохранительными отверстиями Die with 2 securing holes
	Класс точности 6g Tolerance 6g
	Класс точности 6e Tolerance 6e
	Класс точности "Средний" Tolerance "Medium Class"
	Класс точности A Tolerance A
	Коническая резьба 1:16 (NPT - NPTF - R) Tapered thread 1:16 (NPT - NPTF - R)
	Левая резьба Left-hand thread



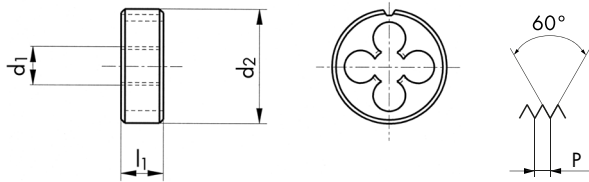







N5110								N5110	N5120	N5120 LH	N5120	
$\emptyset d_1$ M	P mm	d_2 mm	l_1 mm	6g	LH / 6e	$\rightarrow 6g \leftarrow$	$\rightarrow 6e \leftarrow$	ID	ID	ID	ID	6g - mm
1	0.25	16	5	3		0.97		● 103851				
1.1	0.25	16	5	3		1.07		● 124659				
1.2	0.25	16	5	3		1.17		● 103852				
1.4	0.3	16	5	3		1.36		● 103853				
1.6	0.35	16	5	3		1.54		● 103855				
1.7	0.35	16	5	3		1.64		● 103856				
1.8	0.35	16	5	3		1.74		● 103857				
2	0.4	16	5	3		1.93		● 103864				
2.2	0.45	16	5	3		2.13		● 103867				
2.3	0.4	16	5	3		2.23		● 103869				
2.5	0.45	16	5	3		2.43		● 103872				
2.6	0.45	16	5	3		2.53		● 103876				
3	0.5	20	5	3	4	2.92	2.9	● 103879	● 104067	● 104068	● 104066	0.030
3.5	0.6	20	5	3	4	3.41		● 103880	● 104071	● 104072		
4	0.7	20	5	3	4	3.91	3.87	● 103881	● 104114	● 104115	● 104113	0.035
4.5	0.75	20	7	4		4.4		* 103882	● 104117			
5	0.8	20	7	4	4	4.9	4.87	● 103883	● 104146	● 104147	● 104145	0.035
5.5	0.9	20	7	4		5.4		* 103884				
6	1	20	7	4	4	5.88	5.85	● 103885	● 104165	● 104166	● 104164	0.035
7	1	25	9	4	4	6.88		● 103886	● 104174	● 104175		
8	1.25	25	9	4	4	7.87	7.83	● 103887	● 104186	● 104187	● 104185	0.035
9	1.25	25	9	4		8.87		* 103888	● 104191			
10	1.5	30	11	4	4	9.85	9.82	● 103858	● 103953	● 103954	● 103952	0.035
12	1.75	38	14	4	4	11.83	11.8	● 103859	● 103973	● 103974	● 103972	0.035
14	2	38	14	4	4	13.82		● 103860	● 103989	● 103990		
16	2	45	18	4	4	15.82		● 103861	● 104003	● 104004		
18	2.5	45	18	5		17.79			● 104015			
20	2.5	45	18	5	5	19.79		● 103878	● 104028	● 104029		
22	2.5	55	22	5		21.79			● 104035			
24	3	55	22	5	5	23.76			● 104043	● 104044		
27	3	65	25	5		26.76			● 104058			
30	3.5	65	25	6	6	29.73			● 104079	● 104080		
33	3.5	65	25	6		32.73			● 104089			
36	4	65	25	7		35.7			● 104100			
								$\leq M1.4$				



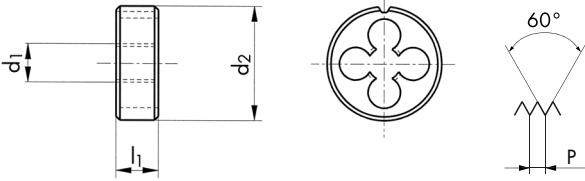







Z5120		Z5120 LL					Z5120	Z5120 LL		
$\emptyset d_1$ M	P mm	d_2 mm	l_1 mm	Z5120	Z5120LL	$\rightarrow 6g \leftarrow$	ID	ID		
2	0.4	16	3.5	4	4	1.93	● 125269	● 105115		
2.5	0.45	16	5	4	4	2.43	● 104779	● 105116		
2.6	0.45	16	5	4		2.53	★ 104780			
3	0.5	20	5	4	5	2.92	● 104788	● 105117		
3.5	0.6	20	5	4		3.41	● 104789			
4	0.7	20	5	4	5	3.91	● 104790	● 105118		
5	0.8	20	7	4	5	4.9	● 104792	● 105119		
6	1	20	7	4	5	5.88	● 104795	● 105120		
7	1	25	9	4		6.88	★ 111424			
8	1.25	25	9	5	6	7.87	● 104798	● 105121		
10	1.5	30	11	5	6	9.85	● 104767	● 105122		
12	1.75	38	14	5	6	11.83	● 104770	● 105123		
14	2	38	14	5		13.82	● 104773			
16	2	45	18	5		15.82	● 104776			
18	2.5	45	18	5		17.79	● 104778			
20	2.5	45	18	5		19.79	● 104783			
24	3	55	22	6		23.76	● 104787			

N5120								N5120	N5120 LH	N5120	Z5120	
Z5120												
								1.75 x P	1.75 x P	1.75 x P	2 x P	
								6g	6g	6e	6g	
Ø d ₁ MF	P mm	d ₂ mm	l ₁ mm	N	Z	6g	6e	ID	ID	ID	6g - mm	ID
*2	0.25	16	5	4		1.93		● 103863				
*2.5	0.35	16	5	4		2.44		● 103871				
3	0.35	20	5	4		2.94		● 104064				
3.5	0.35	20	5	4		3.44		● 104069				
4	0.35	20	5	4		3.94		● 104108				
4	0.5	20	5	4		3.93		● 104110				
4.5	0.5	20	5	4		4.43		● 104116				
5	0.5	20	5	4	4	4.93	4.9	● 104141	● 104142	● 104140	0.030	● 104791
5	0.75	20	7	4		4.9		● 104143				
5.5	0.5	20	5	4		5.43		● 104148				
6	0.5	20	5	4	4	5.93		● 104159	● 104160			● 104793
6	0.75	20	7	4	4	5.9		● 104162	● 104163			● 104794
7	0.5	25	9	4		6.93		● 104169				
7	0.75	25	9	4		6.9		● 104171				
8	0.5	25	9	5		7.93		● 104177				
8	0.75	25	9	4	4	7.9		● 104180				● 104796
8	1	25	9	4	4	7.88	7.85	● 104183	● 104184	● 104182	0.035	● 104797
9	0.5	25	9	5		8.93		● 104188				
9	0.75	25	9	5		8.9		● 104189				
9	1	25	9	5		8.88		● 104190				
10	0.5	30	11	5		9.93		● 103942				
10	0.75	30	11	5	5	9.9		● 103945				● 104765
10	1	30	11	5	5	9.88	9.85	● 103948	● 103949	● 103947	0.035	● 104766
10	1.25	30	11	4		9.86		● 103950	● 103951			
11	0.75	30	11	5		10.9		● 103956				
11	1	30	11	5		10.88		● 103957				
11	1.25	30	11	5		10.86		● 103958				
12	0.5	38	10	5		11.93		● 103960				
12	0.75	38	10	5		11.9		● 103962				
12	1	38	10	5	5	11.88	11.85	● 103965	● 103966	● 103964	0.035	● 104768
12	1.25	38	10	4		11.86		● 103967	● 103968			
12	1.5	38	10	4	5	11.85		● 103970	● 103971			● 104769
13	1	38	10	5		12.88		● 103976				
* N5110								P 0.25 6h				

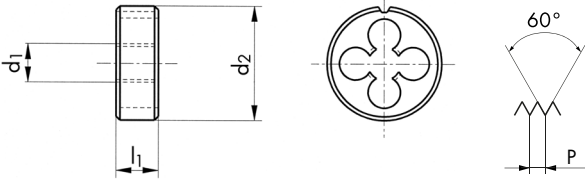
N5120							N5120	N5120 LH	Z5120
$\emptyset d_1$ MF	P mm	d_2 mm	l_1 mm	N	Z	$\rightarrow 6g \leftarrow$	ID	ID	ID
14	0.5	38	10	5		13.93	● 103977		
14	0.75	38	10	5		13.9	● 103979		
14	1	38	10	5	5	13.88	● 103981	● 103982	● 104771
14	1.25	38	10	5		13.86	● 103983		
14	1.5	38	10	5	5	13.85	● 103986	● 103987	● 104772
15	1	38	10	5		14.88	● 103991		
15	1.5	38	10	5		14.85	● 103992		
16	1	45	14	5	5	15.88	● 103996	● 103997	● 104774
16	1.25	45	14	5		15.86	● 103998		
16	1.5	45	14	5	5	15.85	● 104000	● 104001	● 104775
17	1	45	14	5		16.88	● 104005		
18	1	45	14	5		17.88	● 104008		
18	1.5	45	14	5		17.85	● 104011	● 104012	
18	2	45	14	5		17.82	● 104013		
19	1	45	14	6		18.88	● 104017		
20	1	45	14	6	6	19.88	● 104021	● 104022	● 104781
20	1.5	45	14	6	6	19.85	● 104024	● 104025	● 104782
20	2	45	14	6		19.82	● 104026		
21	1	45	14	7		20.88	● 111386		
22	1	55	16	6		21.88	● 104030		
22	1.5	55	16	5		21.85	● 104032		
22	2	55	16	5		21.82	● 104034		
23	1	55	16	6		22.88	● 121704		
24	1	55	16	6		23.88	● 104037		
24	1.5	55	16	6		23.85	● 104039		
24	2	55	16	6		23.82	● 104041	● 104042	
25	1	55	16	6		24.88	● 104045		
25	1.5	55	16	6		24.85	● 104046		
26	1	55	16	7		25.88	● 104049		
26	1.5	55	16	6		25.85	● 104050		
26	2	55	16	6		25.82	● 104052		
27	1	65	18	6		26.88	● 104053		
27	1.5	65	18	6		26.85	● 104054		
27	2	65	18	6		26.82	● 104056		

						N5120	N5120 LH						
<p>N5120  $\geq \text{0.3}$  </p> <p>N5120 LH  $\geq \text{0.3}$   </p>													
						 		 					
$\emptyset d_1$ MF	P mm	d_2 mm	l_1 mm		 $\rightarrow 6g \leftarrow$	ID	ID						
28	1	65	18	6	27.88	● 104060							
28	1.5	65	18	6	27.85	● 104061							
30	1	65	18	7	29.88	● 104073							
30	1.5	65	18	6	29.85	● 104074							
30	2	65	18	6	29.82	● 104076							
32	1.5	65	18	7	31.85	● 104082	* 104083						
33	1.5	65	18	7	32.85	● 104085							
33	2	65	18	7	32.82	● 104086							
34	1.5	65	18	7	33.85	● 104091							
35	1.5	65	18	8	34.85	● 104092							
36	1.5	65	18	8	35.85	● 104095							
36	2	65	18	8	35.82	● 104097							
36	3	65	25	7	35.76	● 104099							
38	1.5	75	20	7	37.85	● 104101							
39	1.5	75	20	7	38.85	● 104104							
40	1.5	75	20	8	39.85	● 104118							
40	2	75	20	7	39.82	● 104120							
42	1.5	75	20	8	41.85	● 104122							
42	3	75	20	8	41.76	● 104125							
45	1.5	90	22	7	44.85	● 104127							
45	2	90	22	7	44.82	● 104129							
48	1.5	90	22	8	47.85	● 104133	* 104134						
48	2	90	22	8	47.82	● 104135							
48	3	90	22	7	47.76	● 104137							
50	1.5	90	22	8	49.85	● 104150							
60	2	105	22	9	59.82	● 104168							











							N5110	N5120		
<p>N5110 </p> <p>N5120  </p>										
							 		 	
Ø" d ₁ UNC	P TPI	d ₁ mm	d ₂ mm	l ₁ mm			ID	ID		
1	64	1.85	16	5	3	1.79	● 103893			
2	56	2.18	16	5	4	2.12	● 103894			
3	48	2.51	16	5	4	2.44	● 103895			
4	40	2.84	16	5	4	2.76	● 103896			
5	40	3.17	20	5	4	3.09		● 104263		
6	32	3.5	20	7	4	3.41		● 104266		
8	32	4.16	20	7	4	4.07		● 104269		
10	24	4.82	20	7	4	4.71		● 104258		
12	24	5.48	20	7	4	5.37		● 104259		
1/4	20	6.35	20	7	4	6.22		● 104256		
5/16	18	7.93	25	9	4	7.8		● 104264		
3/8	16	9.52	30	11	4	9.37		● 104262		
7/16	14	11.11	30	11	4	10.95		● 104267		
1/2	13	12.7	38	14	4	12.52		● 111387		
9/16	12	14.28	38	14	4	14.1		● 104270		
5/8	11	15.87	45	18	4	15.68		● 104265		
3/4	10	19.05	45	18	5	18.84		● 104261		
7/8	9	22.22	55	22	5	22		● 104268		
1	8	25.4	55	22	5	25.16		● 104257		
1 1/4	7	31.75	65	25	6	31.49		● 104251		
1 1/2	6	38.1	75	30	6	37.81		● 104250		
2	4.5	50.8	90	36	7	50.45		★ 104260		

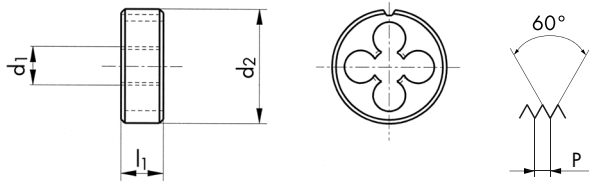











							N5110	N5120		
<p>N5110 </p> <p>N5120  </p>										
							 		 	
Ø" d ₁ UNF	P TPI	d ₁ mm	d ₂ mm	l ₁ mm			ID	ID		
0	80	1.52	16	5	3	1.47	● 103897			
1	72	1.85	16	5	3	1.79	● 103898			
2	64	2.18	16	5	4	2.12	● 103899			
3	56	2.51	16	5	4	2.44	● 103900			
4	48	2.84	16	5	4	2.77	● 103901			
5	44	3.17	20	5	4	3.1		● 104299		
6	40	3.5	20	5	4	3.42		● 104302		
8	36	4.16	20	7	4	4.08		● 104305		
10	32	4.82	20	7	4	4.73		● 104295		
12	28	5.48	20	7	4	5.38		● 104296		
1/4	28	6.35	20	7	4	6.24		● 104293		
5/16	24	7.93	25	9	4	7.82		● 104300		
3/8	24	9.52	30	11	4	9.41		● 104298		
7/16	20	11.11	30	11	5	10.98		● 104303		
1/2	20	12.7	38	10	5	12.56		● 104292		
9/16	18	14.28	38	10	5	14.14		● 104306		
5/8	18	15.87	45	14	5	15.73		● 104301		
3/4	16	19.05	45	14	6	18.89		● 104297		
7/8	14	22.22	55	16	5	22.05		● 104304		
1	12	25.4	55	16	6	25.21		● 104294		
1 1/4	12	31.75	65	18	7	31.56		● 104289		
1 1/2	12	38.1	75	20	7	37.91		● 111390		

UNEF, UNS, UN ASME B1.1

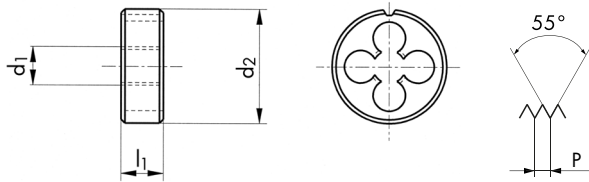
HSS



N5120							N5120			
 										
							 			
Ø" d ₁ UNEF	P TPI	d ₁ mm	d ₂ mm	l ₁ mm		 →2A←	ID			
12	32	5.48	20	7	4	5.39	● 104278			
1/4	32	6.35	20	7	4	6.25	● 104275			
5/16	32	7.93	25	9	4	7.84	● 104283			
3/8	32	9.52	30	11	4	9.42	● 104282			
7/16	28	11.11	30	11	5	11	● 104285			
1/2	28	12.7	38	10	5	12.59	● 104274			
9/16	24	14.28	38	10	5	14.17	● 104287			
5/8	24	15.87	45	14	5	15.75	● 104284			
3/4	20	19.05	45	14	6	18.91	● 104281			
Ø" d ₁ UNS	P TPI	d ₁ mm	d ₂ mm	l ₁ mm		 →2A←	ID			
1/4	40	6.35	20	5	4	6.26	● 104309			
1/4	36	6.35	20	5	4	6.26	● 104308			
7/16	24	11.11	30	11	5	10.99	● 104311			
1/2	24	12.7	38	10	5	12.58	● 104307			
1	14	25.4	55	16	6	25.23	● 104310			
Ø" d ₁ UN	P TPI	d ₁ mm	d ₂ mm	l ₁ mm		 →2A←	ID			
1 1/8	8	28.57	65	25	5	28.33	● 104246			
1 1/4	8	31.75	65	25	6	31.51	● 104245			
1 1/2	8	38.1	75	20	7	37.85	● 104244			
1 3/4	8	44.45	90	22	7	44.2	● 104247			

							N5120	N5120 LH		
<p>N5120  </p> <p>N5120 LH   </p>										
							 		 	
$\frac{\text{Ø}''}{\text{G}}$	P TPI	d ₁ mm	d ₂ mm	l ₁ mm			ID	ID		
1/8	28	9.7	30	11	5	9.62	● 103926			
1/4	19	13.15	38	10	5	13.03	● 103924	● 103925		
3/8	19	16.66	45	14	5	16.54	● 103935	● 103936		
1/2	14	20.95	45	14	6	20.81	● 103922	● 103923		
5/8	14	22.91	55	16	5	22.77	● 103938			
3/4	14	26.44	55	16	6	26.3	● 103933	● 103934		
7/8	14	30.2	65	18	6	30.06	● 103940			
1	11	33.24	65	18	7	33.07	● 103928			
1 1/4	11	41.91	75	20	8	41.73	● 103918			
1 1/2	11	47.8	90	22	8	47.62	● 103917			
2	11	59.61	105	22	9	59.43	● 103932			
2 1/2	11	75.18	120	22	10	74.97	● 103930			

G DIN EN ISO 228 (BSP)

Z MS
HSSE HSS



Z5120								Z5120	MS5120	MS5120	
\emptyset " d ₁ G	P TPI	d ₁ mm	d ₂ mm	l ₁ mm	Z	MS	\rightarrow A \leftarrow	ID	ID	ID	
1/8	28	9.72	30	11	5	5	9.62	● 104761		★ 142831	
1/4	19	13.15	38	10	5	5	13.03	● 104760	● 101338	★ 142832	
3/8	19	16.66	45	14	5	5	16.54	● 104764	● 101342	● 119716	
1/2	14	20.95	45	14	6	6	20.81	● 104759	● 101337	● 119243	
3/4	14	26.44	55	16	6	6	26.3	● 104763	● 101341	● 119648	
1	11	33.24	65	18	8	7	33.07	● 104762	● 101340	● 135186	

N5120 	N5120	

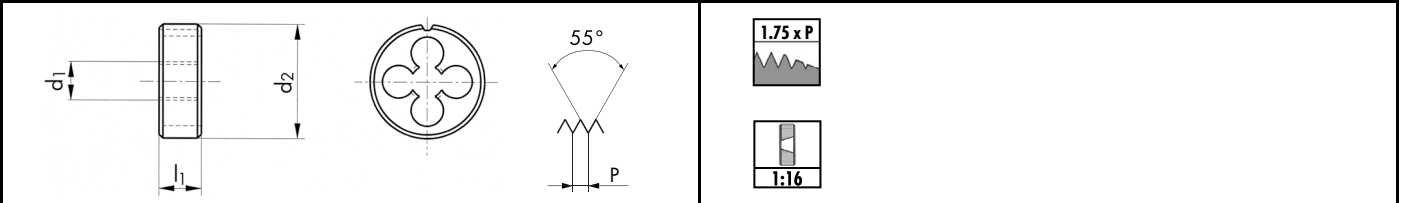





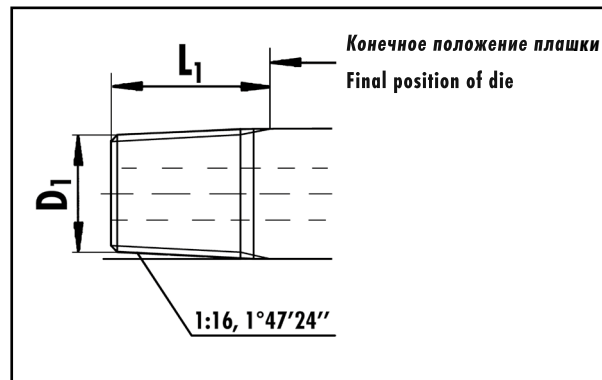



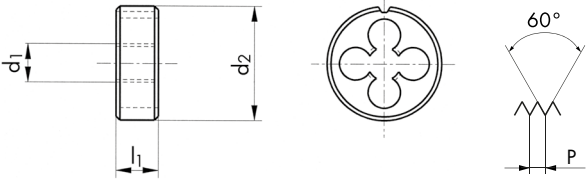

\varnothing'' R	P TPI	d_2 mm	l_1 mm		ID
1/8	28	30	11	5	● 104226
1/4	19	38	14	5	● 104225
3/8	19	45	14	5	● 104230
1/2	14	45	18	6	● 104224
3/4	14	55	22	6	● 104229
1	11	65	25	7	● 104227

Рекомендованные значения диаметров для резьбы R (в мм)
Guide values for turning diameters for R-threads (in mm)



\varnothing'' R	D_1 mini mm	D_1 maxi mm	D_1 (guide line) mm	L_1 (guide line) mm
1/8	9.422	9.534	9.48	8.2
1/4	12.700	12.863	12.78	12.1
3/8	16.181	16.343	16.26	12.5
1/2	20.330	20.555	20.44	16.4
3/4	25.735	25.960	25.85	17.7
1	32.455	32.743	32.60	20.9

<p>N5120  </p> <p>N5120  </p>					N5120	N5120		
					NPT	NPTF		
					 	 		
$\varnothing'' d_1$ NPT, NPTF	P TPI	d_2 mm	l_1 mm		ID	ID		
1/16	27	25	9	4	● 104194			
1/8	27	30	11	5	● 104197			
1/4	18	38	14	5	● 104196			
3/8	18	45	14	5	● 104201			
1/2	14	45	18	6	● 104195	* 104205		
3/4	14	55	22	6	● 104200			
1	11.5	65	25	7	● 104198	* 104208		
1 1/4	11.5	75	26	8	● 104193			

Рекомендованные значения диаметров для резьбы NPT и NPTF (в мм)
Guide values for turning diameters for NPT and NPTF-threads (in mm)

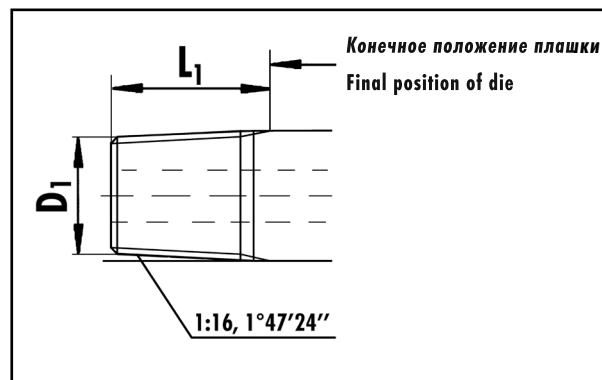

\varnothing'' NPT	D_1 mini mm	D_1 maxi mm	D_1 (guide line) mm	L_1 (guide line) mm	\varnothing'' NPTF	D_1 mini mm	D_1 maxi mm	D_1 (guide line) mm	L_1 (guide line) mm
1/16	7.521	7.643	7.58	8.4	1/16	7.525	7.617	7.57	8.4
1/8	9.866	9.988	9.93	8.5	1/8	9.870	9.962	9.92	8.5
1/4	13.099	13.255	13.18	12.7	1/4	13.129	13.215	13.17	12.7
3/8	16.518	16.674	16.60	12.9	3/8	16.548	16.634	16.59	12.9
1/2	20.551	20.713	20.63	16.8	1/2	20.617	20.703	20.66	16.8
3/4	25.866	26.028	25.95	17.1	3/4	25.932	26.018	25.98	17.1
1	32.419	32.591	32.51	21.3	1	32.475	32.561	32.52	21.3
1 1/4	41.144	41.316	41.23	21.9					



















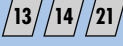

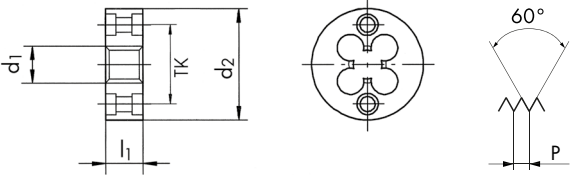
PG DIN 40430 TR DIN 103



N5120		N5120		N5120		N5120		N5120	
								<div style="display: flex; justify-content: space-around;"> <div style="border: 1px solid black; padding: 5px;">PG</div> <div style="border: 1px solid black; padding: 5px;">TR</div> </div>	
Ø d₁ PG	P TPI	d₁ mm	d₂ mm	l₁ mm			ID		
7	20	12.5	38	10	5	12.4	● 104220		
9	18	15.2	38	10	5	15.1	● 104221		
11	18	18.6	45	14	5	18.5	● 104212		
13.5	18	20.4	45	14	6	20.3	● 104213		
16	18	22.5	55	16	5	22.4	● 104214		
42	16	54	90	22	10	53.85	* 104218		
48	16	59.3	105	22	9	59.15	* 104219		
Other sizes on request!									
Ø d₁ TR	P mm	d₂ mm	l₁ mm			7e	ID		
28	5	65	25	5	27.83	* 104240			
32	6	65	25	6	31.81	* 104242			
Other sizes on request!									









							N5120	N5120 LH		
<p>N5120 </p> <p>N5120 LH LH </p>										
$\frac{\text{Ø}''}{W}$ d_1	P TPI	d_1 mm	d_2 mm	l_1 mm			ID	ID		
1/8	40	3.17	20	5	4	3.09	● 104320			
5/32	32	3.96	20	7	4	3.88	● 104333			
3/16	24	4.76	20	7	4	4.66	● 104325			
1/4	20	6.35	20	7	4	6.24	● 104318			
5/16	18	7.93	25	9	4	7.82	● 104331			
3/8	16	9.52	30	11	4	9.4	● 104329			
7/16	14	11.11	30	11	4	10.98	● 104336			
1/2	12	12.7	38	14	4	12.56	● 104316			
5/8	11	15.87	45	18	4	15.72	● 104334			
3/4	10	19.05	45	18	5	18.89	● 104327	* 104328		
1	8	25.4	55	22	5	25.27	● 104322			
1 3/8	6	34.92	65	25	6	34.77	* 104315			

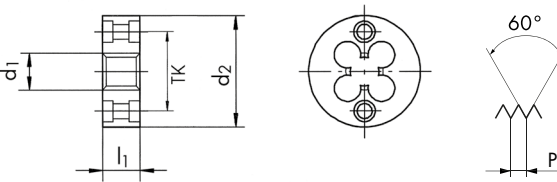

								N5220	N5220	Z5220	
<p>N5220   </p> <p>N5220   </p> <p>Z5220    </p>											
											
											
$\emptyset d_1$ M	P mm	d_2 mm	l_1 mm		TK mm			ID	ID	$6g$ - mm	ID
1.4	0.3	16	2.6	4	12.2	1.36		● 104346			
1.6	0.35	16	2.6	4	12.2	1.54		● 104347			
2	0.4	16	3.5	4	12.2	1.93		● 104367			
2.3	0.4	16	3.5	4	12.2	2.23		● 104369			
2.5	0.45	16	3.5	4	12.2	2.43		● 104371			● 104803
2.6	0.45	16	3.5	4	12.2	2.53		● 104372			
3	0.5	16	3.5	4	12.2	2.92	2.9	● 104375	● 104374	0.030	● 104804
3.5	0.6	16	4	4	12.2	3.41		● 104376			
4	0.7	16	5	4	12.2	3.91	3.87	● 104380	● 104379	0.035	● 104805
5	0.8	20	7	4	15	4.9	4.87	● 104384	● 104383	0.035	● 104806
6	1	20	7	4	15	5.88	5.85	● 104388	● 104387	0.035	● 104807
8	1.25	25	9	4	19	7.87	7.83	● 104397	● 104396	0.035	● 104808
10	1.5	30	11	6	23	9.85	9.82	● 104354	● 104353	0.035	
12	1.75	30	11	6	23	11.83		● 104358			

≤M1.4

6h

N5220							N5220	
								
								
								
								
$\varnothing d_1$ MF	P mm	d_2 mm	l_1 mm		TK mm	 $\rightarrow 6g \leftarrow$	ID	
3	0.35	16	3	4	12.2	2.94	● 104373	
4	0.5	16	4	4	12.2	3.93	● 104378	
5	0.5	20	5	4	15	4.93	● 104382	
6	0.5	20	5	4	15	5.93	● 104385	
6	0.75	20	7	4	15	5.9	● 104386	
7	0.5	25	7	4	19	6.93	* 104389	
7	0.75	25	7	4	19	6.9	* 104390	
10	0.75	30	7	6	23	9.9	* 104350	
10	1.25	25	9	6	19	9.86	* 104352	

N5310						N5310			
$\varnothing d_1$ M	P mm	s mm	l_1 mm		 6g	ID			
3	0.5	18	5	3	2.92	● 104464			
3.5	0.6	18	5	3	3.41	★ 104465			
4	0.7	18	5	3	3.91	● 104478			
4.5	0.75	18	7	3	4.41	★ 104479			
5	0.8	18	7	4	4.9	● 104487			
6	1	18	7	4	5.88	● 104493			
8	1.25	21	9	4	7.87	● 104502			
9	1.25	21	9	5	8.87	★ 104503			
10	1.5	27	11	4	9.85	● 104438			
12	1.75	36	14	4	11.83	● 104443			
14	2	36	14	4	13.82	● 104445			
16	2	41	18	4	15.82	● 104447			
18	2.5	41	18	5	17.79	● 104450			
20	2.5	41	18	5	19.79	● 104453			
22	2.5	50	22	5	21.79	● 104456			
24	3	50	22	5	23.76	● 104459			
30	3.5	60	25	5	29.73	● 104468			
$\varnothing d_1$ MF	P mm	s mm	l_1 mm		 6g	ID			
6	0.75	18	7	4	5.9	★ 104492			
8	0.75	21	9	4	7.9	★ 104500			
8	1	21	9	4	7.88	★ 104501			
12	1	36	10	4	11.88	★ 104440			
27	1.5	60	18	6	26.85	★ 104461			
33	1.5	60	18	7	32.85	★ 104469			
39	1.5	70	20	8	38.85	★ 104476			













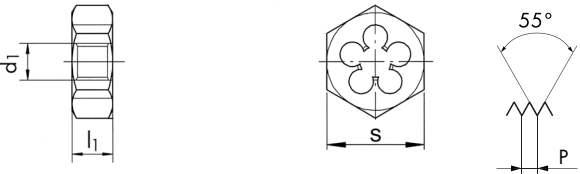

G DIN EN ISO 228 (BSP)

W BS 84 (BSW)

M ISO DIN 13

HSS



							N5310	N5310		N5420	
N5310					11 / 12						
N5310					11 / 12						
N5420					11 / 12						
							 	 		 	
$\emptyset'' d_1$ G	P TPI	d_1 mm	s mm	l_1 mm			ID				
1/4	19	13.15	36	10	5	13.03	●	104428			
3/8	19	16.66	41	14	5	16.54	●	104433			
1/2	14	20.95	41	14	6	20.81	●	104427			
5/8	14	22.91	50	16	6	22.77	*	104434			
3/4	14	26.44	50	16	6	26.3	●	104432			
7/8	14	30.2	60	18	6	30.06	*	104435			
1	11	33.24	60	18	7	33.07	●	104430			
1 3/8	11	44.32	85	22	7	44.14	*	104426			
1 3/4	11	53.74	100	22	8	53.57	*	104425			
$\emptyset'' d_1$ W	P TPI	d_1 mm	s mm	l_1 mm			ID				
1/8	40	3.17	18	5	3	3.09	*	104512			
3/16	24	4.76	18	7	3	4.66	*	104515			
9/16	12	14.28	36	14	4	14.14	*	104522			
1 3/8	6	34.92	60	25	6	34.77	*	104508			
1 1/2	6	38.1	70	30	6	37.95	*	104504			
1 3/4	5	44.45	85	36	6	44.28	*	104507			
2	4.5	50.8	85	36	7	50.63	*	104514			
$\emptyset d_1$ M	P mm	d_2 mm	l_1 mm			ID					
2.5	0.45	16	8	4	2.43	*	104527				
3.5	0.6	16	9.5	4	3.41	*	104530				
8	1.25	25	14	5	7.86	*	104535				

ВЫСОКОТОЧНЫЕ РЕЗЬБОВЫЕ КАЛИБРЫ — PRECISION THREAD GAUGES

D5703



DC "PP" и "HE" резьбовые калибры

размеры согласно DIN 2280 до номинального диаметра 40 мм

DC "Go" / "No-Go" thread plug gauge

Dimensions according to DIN 2280 till nominal diameter 40 mm

D5701-1



DC "PP" резьбовой калибр-пробка

размеры согласно DIN 2281-1;

для номинальных размеров от 40 мм по DIN 2281-2

DC "Go" thread plug gauge

dimensions according to DIN 2281-1;

above nominal diameter of 40 mm as per DIN 2281-2

D5701-2



DC "HE" резьбовой калибр-пробка

размеры согласно DIN 2283-1;

для номинальных размеров от 40 мм по DIN 2283-2

DC "No-Go" thread plug gauge

dimensions according to DIN 2283-1;

above nominal diameter of 40 mm as per DIN 2283-2

D5720



DC "PP-HE" резьбовой калибр-пробка конический ступенчатый

DC "Go" / "No-Go" thread plug gauge conical with step limit

Важное замечание

DC SWISS SA специализируется на производстве резьбовых калибров-пробок с чрезвычайно мелкой резьбой, таких как те, которые часто используются в часовой промышленности, особенно для проверки внутренней резьбы в корпусах часов.

По запросу мы будем рады представить вам соответствующее предложение.

Important note

DC SWISS SA is specialised in the manufacture of thread plug gauges with extremely fine threads, such as those frequently used in the watchmaking industry, especially for checking internal threads in watch cases.

On request, we will be pleased to submit you an appropriate quotation.



ВЫСОКОТОЧНЫЕ РЕЗЬБОВЫЕ КАЛИБРЫ — PRECISION THREAD GAUGES

D5704



DC "PP" резьбовой калибр-кольцо
размеры согласно DIN 2285-1

DC "Go" thread ring gauge
dimensions according to DIN 2285-1

D5714



DC "HE" резьбовой калибр-кольцо
размеры согласно DIN 2299-1

DC "No-Go" thread ring gauge
dimensions according to DIN 2299-1

D5721



DC "PP-HE" резьбовой калибр-кольцо для конической наружной резьбы ступенчатый

DC "Go" / "No-Go" thread ring gauge for tapered external thread with step limit

Резьбовые калибры в наличии на складе без сертификата поверки

Однако все калибры могут быть поставлены в короткие сроки с сертификатом поверки, цена за сертификат по запросу.

Для новых заказанных резьбовых калибров / погрешность измерения U95.

На всех «сертифицированных» резьбовых калибрах будет нанесен идентификационный номер соответствующего сертификата испытаний.













Thread gauges available from stock without test certificate.

However, all gauges can be delivered in short time with test certificate on demand, price for the certificate on request.

For new ordered thread gauges / measuring uncertainty U95.

All "certified" thread gauges will be marked with the identity number of the corresponding test certificate.

Указатель — Резьбовые калибры-пробки и калибры-кольца
Directory — Screw thread plug and ring gauges

Характеристики Characteristics							
							
Тип Type		D5701-1	D5701-2	D5703	D5720	D5722	D5725
M 6H / 6g	ISO DIN 13	294	294	294			
M 6G / 6e	ISO DIN 13			294			
M 6H / 6g LH	ISO DIN 13			294			
MF 6H / 6g	ISO DIN 13	296 - 297	297	296 - 297			
MF 6G / 6e	ISO DIN 13			296			
MF 6H / 6g LH	ISO DIN 13			296			
UNC	ASME B1.1	300		300			
UNF	ASME B1.1	301		301			
UNEF	ASME B1.1			301			
NPT	ASME B1.20.1				303		
NPTF	ANSI B1.20.3				303		
G (BSP)	DIN EN ISO 228	302	302	302			
PG	DIN 40430						302
EG M	ISO DIN 8140			304			
EG UNC	ASME B18.29.1			304			
EG UNF	ASME B18.29.1			304			

Пиктограммы - Pictographs

	"ПР" "Go"
	"НЕ" "No-Go"
	"ПР" / "НЕ" "Go" / "No-Go"
	Класс точности 6H "ПР" Tolerance 6H, "Go"
	Класс точности 6G "ПР" / "НЕ" Tolerance 6G, "Go" / "No-Go"
	Класс точности 6g "НЕ" Tolerance 6g, "No-Go"
	Левая резьба Left-hand thread

Резьбовые калибры в наличии на складе без сертификата проверки.

Однако все калибры могут быть доставлены в короткие сроки с сертификатом по запросу, цена за сертификат по запросу.

Для новых заказанных резьбовых калибров / погрешность измерений U95.

Все "сертифицированные" резьбовые калибры будут маркированы идентификационным номером соответствующего сертификата.













Thread gauges available from stock without test certificate.

However, all gauges can be delivered in short time with test certificate on demand, price for the certificate on request.









For new ordered thread gauges / measuring uncertainty U95.







All "certified" thread gauges will be marked with the identity number of the corresponding test certificate.

D5704	D5714	D5721	D5723
295	295		
295	295		
295			
298 - 299	298 - 299		
298			
300	300		
301	301		
301	301		
		303	
		303	
302	302		
302			



		D5701-1	D5701-2	D5703	D5703 LH	D5703	
D5701-1	M1 - M1.4 = 						
D5703	M1 - M1.4 = 						
$\emptyset d_1$ M	P mm	ID	ID	ID	ID	ID	
1	0.25			● 100242			
1.1	0.25			● 100243			
1.2	0.25			● 100244			
1.4	0.3			● 100245			
1.6	0.35			● 100246			
1.7	0.35			● 100247			
1.8	0.35			● 100248			
2	0.4			● 100278	● 105159	● 104982	
2.2	0.45			● 100280			
2.3	0.4			● 100281			
2.5	0.45			● 100283	● 105160	● 104979	
2.6	0.45			● 100285			
3	0.5			● 100310	● 104964	● 104976	
3.5	0.6			● 100312		● 104977	
4	0.7			● 100333	● 104966	● 104978	
4.5	0.75	* 100114					
5	0.8			● 100348	● 104967	● 104980	
6	1			● 100363	● 104968	● 104981	
7	1			● 100369			
8	1.25			● 100373	● 104969	● 104983	
9	1.25			● 100375			
10	1.5			● 100253	● 104970	● 104984	
11	1.5			* 100256			
12	1.75			● 100261	● 104971	● 104985	
14	2	* 100045		● 100266		● 104986	
16	2			● 100271	● 104973	● 104987	
18	2.5	* 100055		● 100276		* 104988	
20	2.5	* 100068		● 100289	● 104975	● 104989	
22	2.5	* 100072		● 100293	* 110178		
24	3	* 100076		● 100297	● 110179		
27	3			● 100305			
30	3.5			● 100316			
33	3.5	* 100101		● 100322			
36	4	* 100107		● 100328			
39	4	* 100109		● 100330			
42	4.5	● 100119	● 142843				
45	4.5	● 100122	● 142844				
48	5	● 100125	● 142845				
52	5	● 100132	● 142846				
56	5.5	● 100137	● 142847				

M ISO DIN 13 DIN ISO 1502

		D5704	D5704 LH	D5704	D5714	D5714		
D5704	M1 - M1.4 = 							
D5714	M1 - M1.4 = 							
			 LH					
Ø d ₁ M	P mm	ID	ID	ID	ID	ID		
1	0.25	● 100480			● 110419			
1.2	0.25	● 100481			● 110420			
1.4	0.3	● 100482			● 110421			
1.6	0.35	● 100483			● 110422			
1.7	0.35	● 100484			● 111439			
1.8	0.35	● 100485			● 110423			
2	0.4	● 100515	● 105006		● 100734			
2.2	0.45	● 100517			● 100735			
2.3	0.4	● 100518			● 100736			
2.5	0.45	● 100520			● 100737			
2.6	0.45	● 100522			● 100738			
3	0.5	● 100547	● 105001		● 100763			
3.5	0.6	● 100549	● 110302	* 110301	● 100765	* 142836		
4	0.7	● 100570	● 105003		● 100774			
5	0.8	● 100585	● 105004	* 104993	● 100778	* 143406		
6	1	● 100600	● 105005	* 104994	● 100781	* 135556		
7	1	● 100605		* 104995	● 100783			
8	1.25	● 100611	● 105007		● 100786			
9	1.25	● 100610			● 100788			
10	1.5	● 100490	● 105008		● 100711	* 142842		
11	1.5				* 100713			
12	1.75	● 100498	● 105009		● 100718			
14	2	● 100503	● 105010		● 100723			
16	2	● 100508	● 105011		● 100728			
18	2.5	● 100513	● 105012		● 100733			
20	2.5	● 100526	● 105013		● 100742			
22	2.5	● 100530	● 110298		● 100746			
24	3	● 100534			● 100750			
27	3	● 100542			● 100758			
30	3.5	● 100553			● 100769			
33	3.5	* 100559			* 100770			
39	4				* 110440			
45	4.5				* 110448			
56	5.5	* 100595			* 110461			

		D5701-1	D5703	D5703 LH	D5703		
							
				 			
$\emptyset d_1$ MF	P mm	ID	ID	ID	ID		
2.5	0.35		● 100282				
3	0.35		● 100309				
4	0.35		● 100331				
4	0.5		● 100332				
5	0.5		● 100347	● 105016	● 105045		
6	0.5	* 100140	● 100361	● 110184			
6	0.75		● 100362		● 105046		
7	0.5		● 100367				
7	0.75	* 100147	● 100368				
8	0.5	* 100149	● 100370				
8	0.75		● 100371	● 105018	● 105047		
8	1	* 100151	● 100372	● 105019	● 105048		
9	1		● 100374				
10	0.5		● 100249				
10	0.75		● 100250				
10	1		● 100251	● 105020	● 105049		
10	1.25	* 100031	● 100252				
11	1	* 100034	● 100255				
12	0.75	* 100036	● 100257				
12	1		● 100258	● 105021	● 105050		
12	1.25		● 100259				
12	1.5		● 100260	● 105022			
14	1		● 100263	● 110171			
14	1.25		● 100264				
14	1.5		● 100265	● 105023	● 105052		
15	1		● 100267				
15	1.5		● 100268				
16	1		● 100269	● 110172			
16	1.5		● 100270	● 105024	● 105053		
17	1		● 100272				
18	1		● 100273				
18	1.5		● 100274	● 105025	● 105054		
18	2	* 100054	● 100275				
20	1	* 100065	● 100286				
20	1.5		● 100287	● 105026			
20	2	* 100067	● 100288		* 110176		
22	1		● 100290				
22	1.5		● 100291	● 110177			
22	2		● 100292				
24	1		● 100294				
24	1.5		● 100295				
24	2		● 100296				

MF ISO DIN 13 DIN ISO 1502

		D5701-1	D5701-2	D5703			
							
							
$\emptyset d_1$ MF	P mm	ID	ID	ID			
25	1			● 100298			
25	1.5			● 100299			
25	2			● 100300			
26	1			● 100301			
26	1.5	* 100081		● 100302			
27	1.5	* 100082		● 100303			
27	2	* 100083		● 100304			
28	1			● 100306			
28	1.5	* 100086		● 100307			
28	2	* 100087		● 100308			
30	1	* 100092		● 100313			
30	1.5			● 100314			
30	2			● 100315			
32	1			● 100317			
32	1.5			● 100318			
32	2			● 100319			
33	1.5			● 100320			
33	2			● 100321			
35	1.5			● 100323			
36	1.5			● 100325			
36	2			● 100326			
36	3			● 100327			
38	1.5	* 100108		● 100329			
40	1.5			● 100336			
40	2			● 100337			
42	1.5	● 100117	● 142848				
42	2	● 100118	● 142849				
45	1.5	● 100120	● 110127				
45	2	● 100121	● 142851				
48	1.5	● 100123	● 123180				
48	2	● 100124	● 142853				
50	1.5	● 100128	● 142854				
50	2	● 100129	● 142855				
52	1.5	● 100130	● 123428				
52	2	● 100131	● 142857				
55	1.5		● 123468				
55	2	● 100134	● 142859				
56	1.5	● 100135	● 142860				
56	2	● 100136	● 142861				
58	1.5	● 100138	● 142862				
58	2	● 100139	● 142863				
60	1.5	● 100143	● 142864				
60	2	● 100144	● 142865				





		D5704	D5704 LH	D5714			
							
		6g	6g	LH	6g		
Ø d ₁ MF	P mm	ID	ID	ID			
2.5	0.35	● 100519		● 110427			
3	0.35	● 100546		● 100762			
3.5	0.35	● 100548		● 100764			
4	0.35	● 100568		● 100772			
4	0.5	● 100569		● 100773			
4.5	0.5	● 100571		● 100775			
5	0.5	● 100584	● 105057	● 100777			
6	0.5	● 100598	● 110307	● 100779			
6	0.75	● 100599	● 105058	● 100780			
7	0.5	● 100603		● 110467			
7	0.75	● 100604		● 100782			
8	0.5	● 100606					
8	0.75	● 100607	★ 105059	● 100784			
8	1	● 100608	● 105060	● 100785			
9	1	● 100609		● 100787			
10	0.5	● 100486		● 100707			
10	0.75	● 100487		● 100708			
10	1	● 100488	● 105061	● 100709			
10	1.25	● 100489		● 100710			
11	1	● 100492		● 100712			
12	0.75	● 100494		● 100714			
12	1	● 100495	● 105062	● 100715			
12	1.25	● 100496		● 100716			
12	1.5	● 100497	● 105063	● 100717			
13	1	● 100499		● 100719			
14	1	● 100500	● 110290	● 100720			
14	1.25	● 100501		● 100721			
14	1.5	● 100502	● 105064	● 100722			
15	1	● 100504		● 100724			
15	1.5	● 100505		● 100725			
16	1	● 100506	● 110292	● 100726			
16	1.5	● 100507	● 105065	● 100727			
17	1	● 100509		● 100729			
18	1	● 100510		● 100730			
18	1.5	● 100511	● 105066	● 100731			
20	1	● 100523	● 110295	● 100739			
20	1.5	● 100524	● 105067	● 100740			
20	2	● 100525		● 100741			
22	1	● 100527		● 100743			
22	1.5	● 100528		● 100744			
22	2	● 100529		● 100745			
24	1	● 100531		● 100747			
24	1.5	● 100532		● 100748			
24	2	● 100533					

		D5704	D5714				
							
		6g	6g				
$\varnothing d_1$ MF	P mm	ID	ID				
25	1	● 100535					
25	1.5	● 100536					
26	1	● 100538					
26	1.5	● 100539					
27	1.5	● 100540					
27	2	● 100541	* 100757				
28	1	● 100543					
28	1.5	● 100544	* 100760				
30	1	● 100550					
30	1.5	● 100551					
30	2	● 100552					
32	1	● 100554					
32	1.5	● 100555					
32	2	● 100556					
33	1.5	● 100557					
33	2	● 100558	* 110433				
35	1.5	● 100560					
36	1.5	● 100562					
36	2	● 100563					
36	3	● 100564					
38	1.5	● 100566					
40	1.5	● 100573					
42	1.5	● 100575					
42	2	● 100576					
45	1.5	● 100578					
45	2	● 100579					
48	1.5	● 100581	* 110449				
48	2	● 100582					
50	1.5	● 100586					
50	2	● 100587	* 110453				
52	1.5		* 110454				
52	2	● 100589					
55	1.5	● 100591					
55	2	● 100592	* 110458				
56	1.5	● 100593	* 110459				
56	2		* 110460				
58	1.5	● 100596					
58	2	● 100597	* 110463				
60	1.5	● 100601					
60	2	● 105014					

		D5701-1	D5703	D5704	D5714		
Ø" d ₁ UNC	P TPI	ID	ID	ID	ID		
1	64		● 100408	● 110347	● 110473		
2	56		● 100414	● 110353	● 110479		
3	48		● 100416				
4	40	* 110080	● 110224	● 110357	● 110483		
5	40		● 100420				
6	32	* 110084	● 100423	● 110361	● 110487		
8	32		● 100426	● 110364	● 110490		
10	24	* 110074	● 100412	● 110351	● 110477		
12	24		● 100413				
1/4	20		● 100410	● 110349	● 110475		
5/16	18	* 110082	● 100421	● 110359	● 110485		
3/8	16	* 110079	● 100418	● 110356	● 110482		
7/16	14	* 110085	● 100424	● 110362	● 110488		
1/2	13	* 110071	● 100409	● 110348	● 110474		
9/16	12		● 100427	● 110365	* 110491		
5/8	11		● 100422	● 110360			
3/4	10	* 110078	● 100417	● 110355	* 110481		
7/8	9		● 100425	● 110363	* 110489		
1	8	* 110073	● 100411	● 110350	* 110476		
1 1/8	7	* 110068	● 100405	* 110345	* 110471		
1 1/4	7	* 110067	● 100404	* 110344	* 110470		
1 3/8	6	* 110069	● 100407	* 110346	* 110472		
1 1/2	6	* 110066	● 100403	* 110343	* 110469		

UNF, UNEF

ASME B1.1
ANSI / ASME B1.2

		D5701-1	D5703	D5704	D5714		
							
							
Ø" d ₁ UNF	P TPI	ID	ID	ID	ID		
0	80		● 110246				
1	72		● 110251	● 110383	● 110508		
2	64		● 110256	● 110389	● 110514		
3	56		● 110257	● 110390	● 110515		
4	48		● 110260	● 110393	● 110518		
5	44	* 110116					
6	40		● 110264				
8	36	* 110122	● 110267				
10	32		● 110254	● 110387	● 110512		
12	28		● 110255	● 110388	● 110513		
1/4	28	* 110107	● 110006	● 110385	● 110510		
5/16	24	* 110117	● 110262	● 110395	● 110520		
3/8	24	* 110114	● 110259	● 110392	● 110517		
7/16	20	* 110120	● 110265	● 110398	● 111440		
1/2	20	* 110106	● 110252	● 110384	● 110509		
9/16	18		● 110268	● 110401			
5/8	18		● 110263	● 110396			
3/4	16		● 110258	● 110391			
7/8	14		● 110266	● 110399			
1	12		● 128646	● 110386			
1 1/8	12	* 110103	● 110249	● 110381			
1 1/4	12		● 110248	● 110380	* 110505		
1 3/8	12	* 110104	● 110250		* 110507		
1 1/2	12		● 110247	● 110379			
Ø" d ₁ UNEF	P TPI	ID	ID	ID			
12	32	● 110238					
1/4	32	● 110236	● 110368	● 110493			
5/16	32	● 110241	● 110373	● 110498			
3/8	32	● 110240	● 110372	● 110497			
7/16	28	● 110243	● 110375	● 110500			
1/2	28	● 110235	● 110367	● 110492			
9/16	24	● 110245	● 110377	● 110502			
5/8	24	● 110242	● 110374	● 110499			
3/4	20	● 110239	● 110371	● 110496			
7/8	20	● 110244					
1	20	● 110253	● 110369	● 110494			

G DIN EN ISO 228 (BSP)
DIN EN ISO 228-2

PG DIN 40430
DIN 40431



		D5701-1	D5701-2	D5703	D5704	D5714	D5725
$\emptyset'' d_1$ G	P TPI	ID	ID	ID	ID	ID	
1/8	28	* 110044		● 110009	● 110277	● 110408	
1/4	19			● 110003	● 110276	● 110407	
3/8	19	* 110052		● 110162	● 110284	● 110415	
1/2	14			● 110001	● 110275	● 110406	
5/8	14			● 110164	● 110286	● 110417	
3/4	14			● 110161	● 110283	● 110414	
7/8	14	* 110054		● 110165			
1	11			● 110156	● 110278	● 110409	
1 1/8	11			● 110154		* 110404	
1 1/4	11	● 110041	● 119459		● 110272		
1 1/2	11	● 110040	● 119429		● 110271		
1 3/4	11	● 110043	● 142868		● 110274	* 110405	
2	11	● 110050	● 110126		● 110282		
2 1/4	11					* 110411	
2 1/2	11		* 110125				
2 3/4	11					* 110412	
$\emptyset d_1$ PG	P TPI	ID				ID	ID
7	20						● 110216
9	18						● 110217
11	18						● 110205
13.5	18						● 110209
16	18						● 110210
21	16					* 110331	● 110211
29	16						● 110212

NPT

ASME B1.20.1
ASME B1.20.1

NPTF

ANSI B1.20.3
ASA B2.2





		D5720	D5721				
							
							
Ø" d ₁ NPT	P TPI	ID	ID				
1/16	27	● 110190	● 110313				
1/8	27	● 110193	● 110316				
1/4	18	● 110192	● 110315				
3/8	18	● 110197	● 110320				
1/2	14	● 110191	● 110314				
3/4	14	● 110196	● 110319				
1	11.5	● 110194	● 110317				
1 1/4	11.5	● 110189	● 110312				
1 1/2	11.5	● 110188	● 110311				
2	11.5	● 110195	● 110318				
Ø" d ₁ NPTF	P TPI	ID	ID				
1/8	27	● 110201					
1/4	18	● 110200	* 110323				
3/8	18	● 110204					
1/2	14	● 110199	* 110322				
3/4	14	● 110203	* 110326				
1	11.5	● 110202	* 110325				

EG M

ISO DIN 8140-2
DIN ISO 1502

EG UNC, EG UNF

ASME B18.29.1
~ ISO 1502

		D5703	D5703	D5703				
								
								
Ø d, EG M	P mm	ID						
2.5	0.45	● 110132						
3	0.5	● 110133						
4	0.7	● 110134						
5	0.8	● 110135						
6	1	● 110136						
8	1.25	● 110137						
10	1.5	● 110128						
12	1.75	● 110129						
16	2	● 110131						
Ø" d, EG UNC	P TPI	ID						
4	40	● 170252						
6	32	● 170253						
8	32	● 170254						
10	24	● 170255						
1/4	20	● 170256						
5/16	18	● 170257						
3/8	16	● 170258						
Ø" d, EG UNF	P TPI	ID						
6	40	● 170259						
8	36	● 170260						
10	32	● 161020						
1/4	28	● 151790						
5/16	24	● 170261						
3/8	24	● 160134						













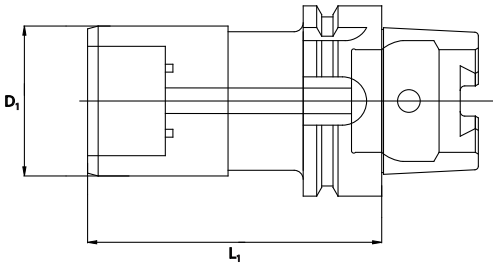









SRT 312  SYNCHRO

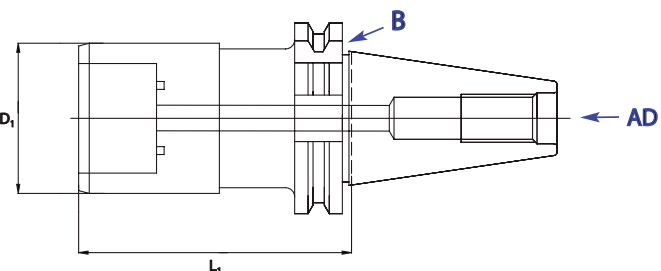

SRT Резьбовые патроны с осевой компенсацией

Tapping chucks with axial shock absorber

 Uniquement pour taraudage synchrone
Nur für Synchronbearbeitung
Only for rigid tapping
Solo per maschietture sincrone
Solo para roscado sincronizado
Только для rigid tapping

DIN 69 893 A	SRT-HSK63-312	SRT-HSK63-820	SRT-HSK63-1433
<h1>HSK</h1>			
			
			
D₁ mm	L₁ mm		
		310	
M3 - M12	36	72	HSK A 63 S1
M8 - M20	53	89	HSK A 63 S2
M14 - M33	78	121	HSK A 63 S3
	ID	ID	ID
	● 170111	● 170112	● 170114
MAS/BT Form AD + B	SRT-BT40-312	SRT-BT40-820	SRT-BT40-1433
<h1>BT</h1>			
			
			
D₁ mm	L₁ mm		
		310	
M3 - M12	36	71	BT40 S1
M8 - M20	53	85	BT40 S2
M14 - M33	78	121	BT40 S3
	ID	ID	ID
	● 170133	● 170134	● 170135

SRT Резьбовые патроны с осевой компенсацией

Tapping chucks with axial shock absorber

 Uniquement pour taraudage synchrone
 Nur für Synchronbearbeitung
 Only for rigid tapping
 Solo per mescolatura sincrona
 Solo para roscado sincronizado
 Только для rigid tapping

DIN 69 871 Form AD + B					SRT-SK40-312	SRT-SK40-820	SRT-SK40-1433
<h1>SK</h1>							
							
							
	D_1 mm	L_1 mm		 310	ID	ID	ID
M3 - M12	36	65	SK40	S1	● 170124		
M8 - M20	53	79	SK40	S2		● 170125	
M14 - M33	78	115	SK40	S3			● 170126
DIN 69 871 Form AD + B					SRT-SK50-820	SRT-SK50-1433	SRT-SK50-2248
<h1>SK</h1>							
							
							
	D_1 mm	L_1 mm		 310	ID	ID	ID
M8 - M20	53	79	SK50	S2	● 170128		
M14 - M33	78	115	SK50	S3		● 170129	
M22 - M48	96	170	SK50	S4			● 170130

SRT Резьбовые патроны с осевой компенсацией

Tapping chucks with axial shock absorber

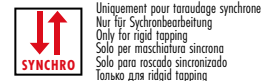









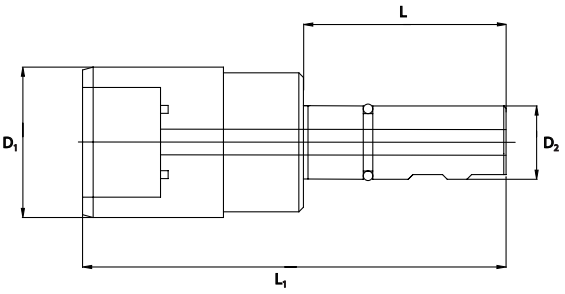













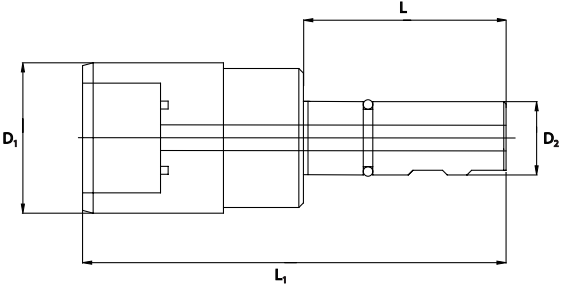



DIN 1835 B	SRT032-D6	SRT054-D12	ER8
<h1>SRT nano</h1>			
SRT032 / SRT054		D9865-	
	D mm	D₁ mm	D₂ mm
M0.3 - M2	12	11	6
M0.5 - M4	12	20	12
	L mm	L₁ mm	L₂ mm
M0.3 - M2	25	40	56
M0.5 - M4	33	59	75
	ID		ID
	● 157610		● 127413
No	D₂ mm	L₃ mm	d₂ mm
ER8-0100	8.5	13.5	1
ER8-0150	8.5	13.5	1.5
ER8-0200	8.5	13.5	2
ER8-0250	8.5	13.5	2.5
ER8-0300	8.5	13.5	3
ER8-0350	8.5	13.5	3.5
ER8-0400	8.5	13.5	4
ER8-0450	8.5	13.5	4.5
	ID		
	● 179401		
	● 179400		
	● 118895		
	● 118896		
	● 118897		
	● 118898		
	● 118899		
	● 118900		
DIN 1835 B	SRT312-D20	SRT312-D25	SRT520-D25
<h1>SRT short</h1>			
	D₁ mm	D₂ mm	L mm
M3 - M12	39	20	47
M3 - M12	39	25	53
M5 - M20	56	25	53
	L₁ mm		
	310		
	ID		ID
	● 162832		● 162831
	● 162833		● 162833
	< 30 bar		< 30 bar
	< 30 bar		< 30 bar

SRT Резьбовые патроны с осевой компенсацией

Tapping chucks with axial shock absorber



 Uniquement pour taraudage synchrone
 Nur für Synchrobearbeitung
 Only for rigid tapping
 Solo per mescolatura sincrona
 Solo para roscado sincronizado
 Только для rigid tapping

DIN 1835 B	SRT-1D20-312	SRT-1D25-312	SRT-2D25-820																												
<h1>SRT</h1>																															
	 	 	 																												
<table border="1"> <thead> <tr> <th></th> <th>D₁ mm</th> <th>D₂ mm</th> <th>L mm</th> <th>L₁ mm</th> <th></th> <th> 310</th> </tr> </thead> <tbody> <tr> <td>M3 - M12</td> <td>36</td> <td>20</td> <td>51</td> <td>97</td> <td>S1</td> <td></td> </tr> <tr> <td>M3 - M12</td> <td>36</td> <td>25</td> <td>57</td> <td>103</td> <td>S1</td> <td></td> </tr> <tr> <td>M8 - M20</td> <td>53</td> <td>25</td> <td>57</td> <td>131</td> <td>S2</td> <td></td> </tr> </tbody> </table>		D ₁ mm	D ₂ mm	L mm	L ₁ mm		 310	M3 - M12	36	20	51	97	S1		M3 - M12	36	25	57	103	S1		M8 - M20	53	25	57	131	S2		ID	ID	ID
	D ₁ mm	D ₂ mm	L mm	L ₁ mm		 310																									
M3 - M12	36	20	51	97	S1																										
M3 - M12	36	25	57	103	S1																										
M8 - M20	53	25	57	131	S2																										
	● 170140		● 170020																												
						● 170141																									
DIN 1835 B	SRT-2D32-820	SRT-3D25-1433	SRT-3D32-1433																												
<h1>SRT</h1>																															
	 	 	 																												
<table border="1"> <thead> <tr> <th></th> <th>D₁ mm</th> <th>D₂ mm</th> <th>L mm</th> <th>L₁ mm</th> <th></th> <th> 310</th> </tr> </thead> <tbody> <tr> <td>M8 - M20</td> <td>53</td> <td>32</td> <td>61.5</td> <td>135.5</td> <td>S2</td> <td></td> </tr> <tr> <td>M14 - M33</td> <td>78</td> <td>25</td> <td>57</td> <td>164.5</td> <td>S3</td> <td></td> </tr> <tr> <td>M14 - M33</td> <td>78</td> <td>32</td> <td>61.5</td> <td>169</td> <td>S3</td> <td></td> </tr> </tbody> </table>		D ₁ mm	D ₂ mm	L mm	L ₁ mm		 310	M8 - M20	53	32	61.5	135.5	S2		M14 - M33	78	25	57	164.5	S3		M14 - M33	78	32	61.5	169	S3		ID	ID	ID
	D ₁ mm	D ₂ mm	L mm	L ₁ mm		 310																									
M8 - M20	53	32	61.5	135.5	S2																										
M14 - M33	78	25	57	164.5	S3																										
M14 - M33	78	32	61.5	169	S3																										
	● 170142																														
			● 170143																												
						● 170144																									

SRT **вставки без предохранительной муфты** Inserts without slipping clutch

 Uniquement pour taraudage synchrone
Nur für Synchronbearbeitung
Only for rigid tapping
Solo per mescolature sincrone
Solo para roscado sincronizado
Только для rigid tapping

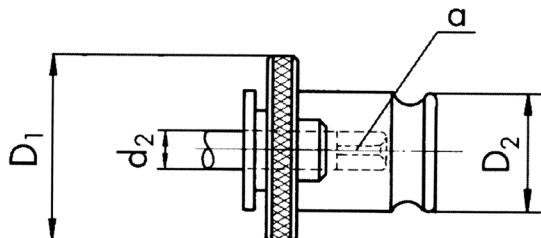
SRT



No	D_1 mm	D_2 mm	d_2 mm	α mm	ID	ID	ID	ID
S1-0028	30	19	2.8	2.1	● 129915			
S1-0035	30	19	3.5	2.7	● 129916			
S1-0045	30	19	4.5	3.4	● 129918			
S1-0060	30	19	6	4.9	● 129920			
S1-0070	30	19	7	5.5	● 129921			
S1-0080	30	19	8	6.2	● 129922			
S1-0090	30	19	9	7	● 129923			
S1-0100	30	19	10	8	● 129924			
S1-0110	30	19	11	9	● 129925			
S2-0060	48	31	6	4.9		● 129927		
S2-0070	48	31	7	5.5		● 129928		
S2-0080	48	31	8	6.2		● 129929		
S2-0090	48	31	9	7		● 129930		
S2-0100	48	31	10	8		● 129931		
S2-0110	48	31	11	9		● 148303		
S2-0120	48	31	12	9		● 129932		
S2-0140	48	31	14	11		● 129933		
S2-0160	48	31	16	12		● 129934		
S2-0180	48	31	18	14.5		● 151355		
S3-0110	70	48	11	9			● 170145	
S3-0120	70	48	12	9			● 170146	
S3-0140	70	48	14	11			● 170147	
S3-0160	70	48	16	12			● 170148	
S3-0180	70	48	18	14.5			● 170149	
S3-0200	70	48	20	16			● 170150	
S3-0220	70	48	22	18			● 170151	
S3-0250	70	48	25	20			● 170152	
S4-0180	96	60	18	14.5				● 170153
S4-0200	96	60	20	16				● 170154
S4-0220	96	60	22	18				● 170155
S4-0250	96	60	25	20				● 170156
S4-0280	96	60	28	22				● 170157
S4-0320	96	60	32	24				● 170158
S4-0360	96	60	36	29				● 170159

вставки с предохранительной муфтой
Inserts with slipping clutch



CLASSIC

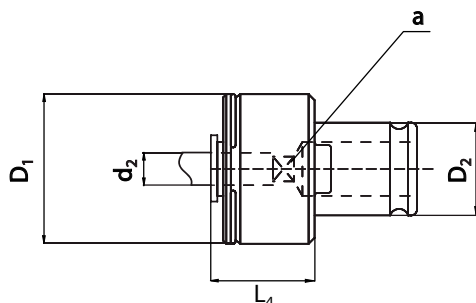

No	D_1 mm	D_2 mm	d_2 mm	a mm	L_4 mm	ID	ID	ID	ID
SC1-0028	32	19	2.8	2.1	25	● 170160			
SC1-0035	32	19	3.5	2.7	25	● 170161			
SC1-0045	32	19	4.5	3.4	25	● 170162			
SC1-0060	32	19	6	4.9	25	● 170163			
SC1-0070	32	19	7	5.5	25	● 170164			
SC1-0080	32	19	8	6.2	25	● 170165			
SC1-0090	32	19	9	7	25	● 170166			
SC1-0100	32	19	10	8	25	● 170167			
SC2-0060	50	31	6	4.9	34		● 170168		
SC2-0070	50	31	7	5.5	34		● 170169		
SC2-0080	50	31	8	6.2	34		● 170170		
SC2-0090	50	31	9	7	34		● 170171		
SC2-0100	50	31	10	8	34		● 170172		
SC2-0110	50	31	11	9	34		● 170173		
SC2-0120	50	31	12	9	34		● 170174		
SC2-0140	50	31	14	11	34		● 170175		
SC2-0160	50	31	16	12	34		● 170176		
SC2-0180	50	31	18	14.5	34		● 170177		
SC3-0110	72	48	11	9	45			● 170178	
SC3-0120	72	48	12	9	45			● 170179	
SC3-0140	72	48	14	11	45			● 170180	
SC3-0160	72	48	16	12	45			● 170181	
SC3-0180	72	48	18	14.5	45			● 170182	
SC3-0200	72	48	20	16	45			● 170183	
SC3-0220	72	48	22	18	45			● 170184	
SC3-0250	72	48	25	20	45			● 170185	
SC4-0180	96	60	18	14.5	68				● 170186
SC4-0200	96	60	20	16	68				● 170187
SC4-0220	96	60	22	18	68				● 170188
SC4-0250	96	60	25	20	68				● 170189
SC4-0280	96	60	28	22	68				● 170190
SC4-0320	96	60	32	24	68				● 170191
SC4-0360	96	60	36	29	68				● 170192

ТАБЛИЦА ПРИМЕНЕНИЯ — APPLICATION CHART

Циклы программирования для центровочных сверл C315VS Programming cycle for spotting drills C315VS

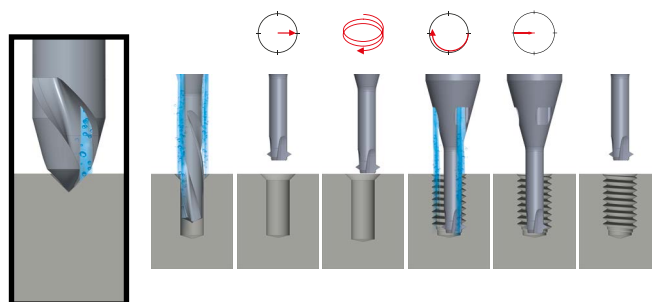

DC Классификация материалов

DC Material classification

Группы материалов Material groups	Обозначение материалов	Material designation	Твердость Hardness (HB)	Предел прочности Tensile strength Rm (N/mm ²)	Смазка Lubricant Покрытые Coated	
10 Стали Steels	11	Легко обрабатываемые стали	Free-cutting steels	< 200	< 700	○ E
	12	Структурные, цементуемые стали	Structural, cementation steels	< 200	< 700	○ E
	13	Углеродистые стали	Carbon steels	< 300	< 1000	○ E
	14	Легированные стали < 850 N/mm ²	Alloy steels < 850 N/mm ²	< 250	< 850	○ E
	15	Легированные стали закал./отп. > 850 - < 1150 N/mm ²	Alloy steels hard./temp. > 850 - < 1150 N/mm ²	> 250	> 850	○ E
	16	Высокопрочные легированные стали ≤ 44 HRC	High tensile alloy steels ≤ 44 HRC	> 250	> 850	○ E
	17	Закалённые легированные стали > 44 - ≤ 54 HRC	Alloy steels tempered > 44 - ≤ 54 HRC	> 410	> 1400	○ E
	18	Закалённые легированные стали > 54 - ≤ 63 HRC	Alloy steels hardened > 54 - ≤ 63 HRC	> 560	> 1980	○ E
20 Нержавеющие стали Stainless steels	21	Легко обрабатываемые нержавеющие стали	Free machining stainless steels	< 250	< 850	○ E
	22	Аустенитные нержавеющие стали	Austenitic stainless steels	< 250	< 850	○ E
	23	Ферритные и мартенситные < 850 N/mm ²	Ferritic and martensitic < 850 N/mm ²	< 250	< 850	○ E
	24	Ферритные и мартенситные > 850 - < 1150 N/mm ²	Ferritic and martensitic > 850 - < 1150 N/mm ²	> 250	> 850	○ E
30 Чугун Cast iron	31	Чугун	Cast iron	< 250	< 850	○ E
	32	Высокопрочные и ковкий чугун	Spheroidal graphite + malleable cast iron	< 250	< 850	○ E
40 Титан Titanium	41	Чистый титан	Pure titanium	< 250	< 850	○ E
	42	Титановые сплавы	Titanium alloys	> 250	> 850	○ E
50 Никель Nickel	51	Никелевые сплавы 1 ≤ 850 N/mm ²	Nickel alloys 1 ≤ 850 N/mm ²	< 250	< 850	○ E
	52	Никелевые сплавы 2 > 850 - ≤ 1150 N/mm ²	Nickel alloys 2 > 850 - ≤ 1150 N/mm ²	> 250	> 850	○ E
	53	Никелевые сплавы 3 > 1150 - ≤ 1600 N/mm ²	Nickel alloys 3 > 1150 - ≤ 1600 N/mm ²	> 340	> 1150	○ E
60 Медь Copper	61	Медь чистая (электрохимическая)	Pure copper (electrolytic copper)	< 120	< 400	○ E
	62	Короткостружечная латунь, фосфористая бронза	Short chip brass, phosphor bronze, gun metal	< 200	< 700	○ E
	63	Длинностружечная латунь	Long chip brass	< 200	< 700	○ E
	64	безсвинцовая латунь	Lead free brass	< 220	< 700	○ E
70 Алюминий Магний Aluminium Magnesium	71	Алюминий чистый	Al unalloyed	< 100	< 350	○ E
	72	Алюминиевые сплавы Si < 1.5 %	Al alloyed Si < 1.5 %	< 150	< 500	○ E
	73	Алюминиевые сплавы Si > 1.5 % - < 10 %	Al alloyed Si > 1.5 % - < 10 %	< 120	< 400	○ E
	74	Алюминиевые сплавы Si > 10 %, магниевые сплавы	Al alloyed Si > 10 %, Mg-alloys	< 120	< 400	○ E
80 Пластики Plastic compounds	81	Термопластики	Thermoplastics	-	-	E
	82	Дюропластики	Duroplastics	-	-	E
	83	Пластики армированные стекловолокном	Glass fibre reinforced plastics	-	-	E
90 Драгоценные металлы Precious metals	91	Желтое золото	Yellow gold	-	-	○ E
	92	Красное золото	Red gold	-	-	○ E
	93	Белое золото	White gold	-	-	○ E
	94	Серебро	Silver	-	-	○ E

ЦЕНТРОВОЧНЫЕ СВЕРЛА C315VS — SPOTTING DRILLS C315VS



	V _c (m/min) Guide Line Покрытые Coated	C315VS						
		Подача f (мм/об)			Feed rate f (мм/rev.)			
		Ø 1.40	Ø 2.00	Ø 3.00	Ø 4.00	Ø 6.00	Ø 8.00	
11	120	0.05	0.08	0.10	0.12	0.15	0.20	11
12	120	0.05	0.08	0.10	0.12	0.15	0.20	12
13	120	0.05	0.08	0.10	0.12	0.15	0.20	13
14	80	0.05	0.08	0.10	0.12	0.15	0.20	14
15	60	0.03	0.04	0.06	0.08	0.12	0.18	15
16	40	0.02	0.03	0.04	0.05	0.06	0.07	16
17	40	0.02	0.03	0.04	0.05	0.06	0.07	17
18								18
21	60	0.03	0.04	0.06	0.08	0.12	0.18	21
22	50	0.03	0.04	0.06	0.07	0.09	0.11	22
23	50	0.03	0.04	0.06	0.07	0.09	0.11	23
24	50	0.03	0.04	0.06	0.07	0.09	0.11	24
31	100	0.04	0.05	0.07	0.09	0.11	0.15	31
32	100	0.04	0.05	0.07	0.09	0.11	0.15	32
41	25	0.03	0.04	0.06	0.07	0.09	0.11	41
42	25	0.04	0.07	0.09	0.11	0.14	0.18	42
51	25	0.025	0.03	0.04	0.05	0.07	0.09	51
52	20	0.025	0.03	0.04	0.05	0.07	0.09	52
53	10	0.025	0.03	0.04	0.05	0.07	0.09	53
61	100	0.06	0.09	0.11	0.13	0.18	0.23	61
62	100	0.06	0.09	0.11	0.13	0.16	0.18	62
63	80	0.06	0.09	0.11	0.13	0.16	0.18	63
64	80	0.06	0.09	0.11	0.13	0.16	0.18	64
71	150	0.06	0.09	0.11	0.13	0.18	0.23	71
72	150	0.06	0.09	0.11	0.13	0.18	0.23	72
73	100	0.06	0.09	0.11	0.13	0.18	0.23	73
74	100	0.06	0.09	0.11	0.13	0.18	0.23	74
81	200	0.08	0.11	0.13	0.15	0.20	0.25	81
82	200	0.08	0.11	0.13	0.15	0.20	0.25	82
83	100	0.08	0.11	0.13	0.15	0.20	0.25	83
91	200	0.08	0.11	0.13	0.15	0.20	0.25	91
92	150	0.08	0.11	0.13	0.15	0.20	0.25	92
93	100	0.08	0.11	0.13	0.15	0.20	0.25	93
94	100	0.08	0.11	0.13	0.15	0.20	0.25	94

Указаны ориентировочные значения.
The indicated values are a guideline.

ТАБЛИЦА ПРИМЕНЕНИЯ — APPLICATION CHART

Циклы программирования для спиральных сверл FZ315VS Programming cycle for twist drills FZ315VS

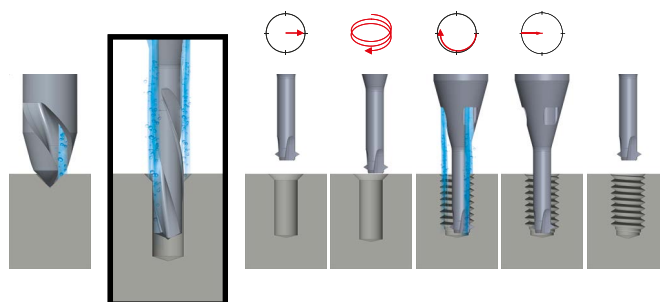



DC Классификация материалов

DC Material classification

Группы материалов Material groups	Обозначение материалов	Material designation	Твердость Hardness (НВ)	Предел прочности Tensile strength Rm (N/mm ²)	Смазка Lubricant Покрытые Coated	
10 Стали Steels	11	Легко обрабатываемые стали	Free-cutting steels	< 200	< 700	○ E
	12	Структурные, цементуемые стали	Structural, cementation steels	< 200	< 700	○ E
	13	Углеродистые стали	Carbon steels	< 300	< 1000	○ E
	14	Легированные стали < 850 N/mm ²	Alloy steels < 850 N/mm ²	< 250	< 850	○ E
	15	Легированные стали закал./отп. > 850 - < 1150 N/mm ²	Alloy steels hard. / temp. > 850 - < 1150 N/mm ²	> 250	> 850	○ E
	16	Высокопрочные легированные стали ≤ 44 HRC	High tensile alloy steels ≤ 44 HRC	> 250	> 850	○ E
	17	Закалённые легированные стали > 44 - ≤ 54 HRC	Alloy steels tempered > 44 - ≤ 54 HRC	> 410	> 1400	○ E
	18	Закалённые легированные стали > 54 - ≤ 63 HRC	Alloy steels hardened > 54 - ≤ 63 HRC	> 560	> 1980	
20 Нержавеющие стали Stainless steels	21	Легко обрабатываемые нержавеющие стали	Free machining stainless steels	< 250	< 850	○ E
	22	Аустенитные нержавеющие стали	Austenitic stainless steels	< 250	< 850	○ E
	23	Ферритные и мартенситные < 850 N/mm ²	Ferritic and martensitic < 850 N/mm ²	< 250	< 850	○ E
	24	Ферритные и мартенситные > 850 - < 1150 N/mm ²	Ferritic and martensitic > 850 - < 1150 N/mm ²	> 250	> 850	○ E
30 Чугун Cast iron	31	Чугун	Cast iron	< 250	< 850	○ E
	32	Высокопрочные и ковкий чугун	Spheroidal graphite + malleable cast iron	< 250	< 850	○ E
40 Титан Titanium	41	Чистый титан	Pure titanium	< 250	< 850	○ E
	42	Титановые сплавы	Titanium alloys	> 250	> 850	○ E
50 Никель Nickel	51	Никелевые сплавы 1 ≤ 850 N/mm ²	Nickel alloys 1 ≤ 850 N/mm ²	< 250	< 850	○ E
	52	Никелевые сплавы 2 > 850 - ≤ 1150 N/mm ²	Nickel alloys 2 > 850 - ≤ 1150 N/mm ²	> 250	> 850	○ E
	53	Никелевые сплавы 3 > 1150 - ≤ 1600 N/mm ²	Nickel alloys 3 > 1150 - ≤ 1600 N/mm ²	> 340	> 1150	○ E
60 Медь Copper	61	Медь чистая (электротехническая)	Pure copper (electrolytic copper)	< 120	< 400	○ E
	62	Короткостружечная латунь, фосфористая бронза	Short chip brass, phosphor bronze, gun metal	< 200	< 700	○ E
	63	Длинностружечная латунь	Long chip brass	< 200	< 700	○ E
	64	безсвинцовая латунь	Lead free brass	< 220	< 700	○ E
70 Алюминий Магний Aluminium Magnesium	71	Алюминий чистый	Al unalloyed	< 100	< 350	○ E
	72	Алюминиевые сплавы Si < 1.5 %	Al alloyed Si < 1.5 %	< 150	< 500	○ E
	73	Алюминиевые сплавы Si > 1.5 % - < 10 %	Al alloyed Si > 1.5 % - < 10 %	< 120	< 400	○ E
	74	Алюминиевые сплавы Si > 10 %, магниевые сплавы	Al alloyed Si > 10 %, Mg-alloys	< 120	< 400	○ E
80 Пластики Plastic compounds	81	Термопластики	Thermoplastics	-	-	E
	82	Дюропластики	Duroplastics	-	-	E
	83	Пластики армированные стекловолокном	Glass fibre reinforced plastics	-	-	E
90 Драгоценные металлы Precious metals	91	Желтое золото	Yellow gold	-	-	○ E
	92	Красное золото	Red gold	-	-	○ E
	93	Белое золото	White gold	-	-	○ E
	94	Серебро	Silver	-	-	○ E

СПИРАЛЬНЫЕ СВЕРЛА FZ315VS – TWIST DRILLS FZ315VS

		FZ315VS						FZ315VS							
		VS VS VS VS						VS VS VS 							
V _c (m/min) Guide Line Ø 0.58 - 2.0		Поддача f (мм/об)				Feed rate f (mm/rev.)		V _c (m/min) Guide Line Ø 2.01 - 5.4		Поддача f (мм/об)				Feed rate f (mm/rev.)	
Покрытые Coated		Ø0.58-0.82	Ø0.83-1.07	Ø1.08-1.46	Ø1.47-2.0	Q1	Qx	Покрытые Coated		Ø2.01-3.05	Ø3.06-4.5	Ø4.51-5.4	Qx		
11	40 - 60	0.02-0.035	0.03-0.045	0.04-0.055	0.05-0.065	1xd,-4xd	1xd,-2xd	80 - 110	0.07-0.12	0.12-0.18	0.18-0.23		11		
12	40 - 60	0.02-0.035	0.03-0.045	0.04-0.055	0.05-0.065	1xd,-4xd	1xd,-2xd	80 - 110	0.07-0.12	0.12-0.17	0.17-0.22		12		
13	35 - 55	0.015-0.025	0.025-0.035	0.035-0.045	0.045-0.055	1xd,-4xd	1xd,-2xd	70 - 100	0.07-0.12	0.12-0.17	0.17-0.22		13		
14	35 - 55	0.015-0.025	0.025-0.035	0.035-0.045	0.045-0.055	1xd,-4xd	1xd,-2xd	70 - 100	0.07-0.12	0.12-0.17	0.17-0.22		14		
15	35 - 55	0.015-0.025	0.025-0.035	0.035-0.045	0.045-0.055	1xd,-4xd	1xd,-2xd	70 - 100	0.07-0.12	0.12-0.17	0.17-0.22		15		
16	35 - 55	0.015-0.025	0.025-0.035	0.035-0.045	0.045-0.055	1xd,-4xd	1xd,-2xd	70 - 100	0.07-0.10	0.10-0.14	0.14-0.17		16		
17	30 - 45	0.015-0.025	0.025-0.035	0.035-0.045	0.045-0.055	1xd,-4xd	1xd,-2xd	60 - 80	0.07-0.10	0.10-0.15	0.14-0.18		17		
18													18		
21	30 - 45	0.015-0.025	0.025-0.035	0.035-0.045	0.045-0.055	1xd,-4xd	1xd,-2xd	60 - 80	0.045-0.055	0.055-0.07	0.07-0.10		21		
22	30 - 45	0.015-0.025	0.025-0.035	0.035-0.045	0.045-0.055	1xd,-4xd	1xd,-2xd	60 - 80	0.045-0.055	0.055-0.07	0.07-0.10		22		
23	35 - 50	0.02-0.025	0.025-0.035	0.04-0.05	0.05-0.065	1xd,-4xd	1xd,-2xd	60 - 80	0.05-0.065	0.05-0.065	0.06-0.09		23		
24	35 - 50	0.02-0.025	0.025-0.035	0.04-0.05	0.05-0.065	1xd,-4xd	1xd,-2xd	60 - 80	0.05-0.065	0.05-0.065	0.06-0.09		24		
31	50 - 80	0.025-0.045	0.045-0.065	0.065-0.085	0.085-0.10	4xd,-8xd	4xd	90 - 130	0.10-0.15	0.15-0.20	0.20-0.25		31		
32	40 - 70	0.025-0.045	0.045-0.065	0.065-0.085	0.085-0.10	4xd,-8xd	4xd	80 - 120	0.10-0.14	0.14-0.18	0.18-0.23		32		
41	15 - 25	0.005-0.02	0.015-0.045	0.04-0.06	0.055-0.07	1/2xd,-1xd	1/4xd,-1/2xd	30 - 40	0.055-0.07	0.055-0.07	0.055-0.07	1/3xd,-1/2xd	41		
42	15 - 25	0.005-0.02	0.015-0.045	0.04-0.06	0.055-0.07	1/2xd,-1xd	1/4xd,-1/2xd	30 - 40	0.055-0.07	0.055-0.07	0.055-0.07	1/3xd,-1/2xd	42		
51	15 - 25	0.005-0.02	0.02-0.025	0.025-0.035	0.035-0.05	1/2xd,-1xd	1/2xd	30 - 40	0.035-0.05	0.035-0.05	0.05-0.08		51		
52	15 - 25	0.015-0.02	0.02-0.025	0.025-0.035	0.035-0.05	1/2xd,-1xd	1/2xd	30 - 40	0.035-0.05	0.035-0.05	0.05-0.08		52		
53	15 - 25	0.005-0.01	0.01-0.02	0.02-0.03	0.03-0.04	1/2xd,-1xd	1/2xd	30 - 40	0.03-0.04	0.03-0.04	0.04-0.06		53		
61	50 - 80	0.05-0.08	0.06-0.10	0.08-0.12	0.12-0.15	4xd,-8xd	4xd	130 - 180	0.12-0.15	0.15-0.20	0.20-0.25		61		
62	50 - 80	0.05-0.08	0.06-0.10	0.08-0.12	0.12-0.15	4xd,-8xd	4xd	130 - 180	0.12-0.15	0.15-0.20	0.20-0.25		62		
63	50 - 80	0.05-0.08	0.06-0.10	0.08-0.12	0.12-0.15	4xd,-8xd	4xd	80 - 110	0.12-0.15	0.14-0.18	0.18-0.23		63		
64	50 - 80	0.05-0.08	0.06-0.1	0.08-0.12	0.12-0.15	4xd,-8xd	4xd	80 - 110	0.12-0.15	0.14-0.18	0.18-0.23		64		
71	50 - 80	0.05-0.08	0.06-0.10	0.08-0.12	0.12-0.15	2xd,-3xd	3xd	130 - 180	0.12-0.15	0.15-0.20	0.20-0.25		71		
72	50 - 80	0.05-0.08	0.06-0.10	0.08-0.12	0.12-0.15	2xd,-3xd	3xd	130 - 180	0.12-0.15	0.15-0.20	0.20-0.25		72		
73	50 - 80	0.05-0.08	0.06-0.10	0.08-0.12	0.12-0.15	2xd,-3xd	3xd	100 - 130	0.12-0.15	0.14-0.18	0.18-0.23		73		
74	50 - 80	0.05-0.08	0.06-0.10	0.08-0.12	0.12-0.15	2xd,-3xd	3xd	100 - 130	0.12-0.15	0.14-0.18	0.18-0.23		74		
81	50 - 80	0.05-0.08	0.06-0.10	0.08-0.12	0.12-0.15	4xd,-8xd	4xd	130 - 180	0.12-0.15	0.15-0.20	0.20-0.25		81		
82	50 - 80	0.05-0.08	0.06-0.10	0.08-0.12	0.12-0.15	4xd,-8xd	4xd	130 - 180	0.12-0.15	0.15-0.20	0.20-0.25		82		
83	40 - 60	0.02-0.035	0.03-0.045	0.04-0.055	0.05-0.065	2xd,-3xd	3xd	80 - 120	0.07-0.12	0.12-0.18	0.18-0.23		83		
91	50 - 80	0.02-0.035	0.03-0.045	0.04-0.055	0.05-0.065	2xd,-3xd	3xd	130 - 180	0.07-0.12	0.12-0.17	0.17-0.22		91		
92	50 - 80	0.02-0.035	0.03-0.045	0.04-0.055	0.05-0.065	2xd,-3xd	3xd	130 - 180	0.07-0.12	0.12-0.17	0.17-0.22		92		
93	40 - 60	0.02-0.035	0.03-0.045	0.04-0.055	0.05-0.065	2xd,-3xd	3xd	80 - 110	0.07-0.12	0.12-0.17	0.17-0.22		93		
94	40 - 60	0.02-0.035	0.03-0.045	0.04-0.055	0.05-0.065	2xd,-3xd	3xd	80 - 110	0.07-0.12	0.12-0.17	0.17-0.22		94		

Указаны ориентировочные значения.
The indicated values are a guideline.

ТАБЛИЦА ПРИМЕНЕНИЯ — APPLICATION CHART

DC Классификация материалов

DC Material classification

Группы материалов Material groups	Обозначение материалов	Material designation	Твердость Hardness (HV)	Предел прочности Tensile strength Rm (N/mm ²)	Смазка Lubricant Покрытые Coated	
10 Стали Steels	11	Легко обрабатываемые стали	Free-cutting steels	< 200	< 700	
	12	Структурные, цементуемые стали	Structural, cementation steels	< 200	< 700	
	13	Углеродистые стали	Carbon steels	< 300	< 1000	
	14	Легированные стали < 850 N/mm ²	Alloy steels < 850 N/mm ²	< 250	< 850	
	15	Легированные стали закал./отп. > 850 - < 1150 N/mm ²	Alloy steels hard./temp. > 850 - < 1150 N/mm ²	> 250	> 850	
	16	Высокопрочные легированные стали ≤ 44 HRC	High tensile alloy steels ≤ 44 HRC	> 250	> 850	
	17	Закалённые легированные стали > 44 - ≤ 54 HRC	Alloy steels tempered > 44 - ≤ 54 HRC	> 410	> 1400	
	18	Закалённые легированные стали > 54 - ≤ 63 HRC	Alloy steels hardened > 54 - ≤ 63 HRC	> 560	> 1980	
20 Нержавеющие стали Stainless steels	21	Легко обрабатываемые нержавеющие стали	Free machining stainless steels	< 250	< 850	
	22	Аустенитные нержавеющие стали	Austenitic stainless steels	< 250	< 850	
	23	Ферритные и мартенситные < 850 N/mm ²	Ferritic and martensitic < 850 N/mm ²	< 250	< 850	
	24	Ферритные и мартенситные > 850 - < 1150 N/mm ²	Ferritic and martensitic > 850 - < 1150 N/mm ²	> 250	> 850	
30 Чугун Cast iron	31	Чугун	Cast iron	< 250	< 850	
	32	Высокопрочные и ковкий чугун	Spheroidal graphite + malleable cast iron	< 250	< 850	
40 Титан Titanium	41	Чистый титан	Pure titanium	< 250	< 850	
	42	Титановые сплавы	Titanium alloys	> 250	> 850	
50 Никель Nickel	51	Никелевые сплавы 1 ≤ 850 N/mm ²	Nickel alloys 1 ≤ 850 N/mm ²	< 250	< 850	
	52	Никелевые сплавы 2 > 850 - ≤ 1150 N/mm ²	Nickel alloys 2 > 850 - ≤ 1150 N/mm ²	> 250	> 850	
	53	Никелевые сплавы 3 > 1150 - ≤ 1600 N/mm ²	Nickel alloys 3 > 1150 - ≤ 1600 N/mm ²	> 340	> 1150	
60 Медь Copper	61	Медь чистая (электротехническая)	Pure copper (electrolytic copper)	< 120	< 400	
	62	Короткостружечная латунь, фосфористая бронза	Short chip brass, phosphor bronze, gun metal	< 200	< 700	
	63	Длинностружечная латунь	Long chip brass	< 200	< 700	
	64	безсвинцовая латунь	Lead free brass	< 220	< 700	
70 Алюминий Магний Aluminium Magnesium	71	Алюминий чистый	Al unalloyed	< 100	< 350	
	72	Алюминиевые сплавы Si < 1.5 %	Al alloyed Si < 1.5 %	< 150	< 500	
	73	Алюминиевые сплавы Si > 1.5 % - < 10 %	Al alloyed Si > 1.5 % - < 10 %	< 120	< 400	
	74	Алюминиевые сплавы Si > 10 %, магниевые сплавы	Al alloyed Si > 10 %, Mg-alloys	< 120	< 400	
80 Пластики Plastic compounds	81	Термопластики	Thermoplastics	-	-	
	82	Дюропластики	Duroplastics	-	-	
	83	Пластики армированные стекловолокном	Glass fibre reinforced plastics	-	-	
90 Драгоценные металлы Precious metals	91	Желтое золото	Yellow gold	-	-	
	92	Красное золото	Red gold	-	-	
	93	Белое золото	White gold	-	-	
	94	Серебро	Silver	-	-	

F286VS — F286VS



		F286VS							
		VS	VS	VS	VS	VS	VS		
		Поддача f (мм/об)			Feed rate f (mm/rev.)				
Vc (m/min) Guide Line		Ø 0.8 - 1.2	Ø 1.21 - 3.0	Ø 3.01 - 6.0	Ø 6.01 - 8.5	Ø 8.51 - 11.0	Ø 11.02 - 14.0		
Покрытые Coated									
11	70 - 90	0.015-0.025	0.015-0.025	0.035-0.045	0.11-0.13	0.15-0.17	0.18-0.22	11	
12	70 - 90	0.10-0.20	0.015-0.025	0.035-0.045	0.11-0.13	0.15-0.17	0.18-0.22	12	
13	70 - 90	0.10-0.20	0.015-0.025	0.035-0.045	0.11-0.13	0.15-0.17	0.18-0.22	13	
14	70 - 90	0.10-0.20	0.015-0.025	0.035-0.045	0.11-0.13	0.15-0.17	0.18-0.22	14	
15	60 - 80	0.10-0.20	0.015-0.025	0.035-0.045	0.07-0.09	0.11-0.13	0.15-0.17	15	
16								16	
17								17	
18								18	
21	40 - 60	0.008-0.012	0.015-0.02	0.035-0.04	0.075-0.085	0.095-0.105	0.15-0.16	21	
22	40 - 60	0.008-0.012	0.015-0.02	0.035-0.04	0.075-0.085	0.095-0.105	0.15-0.16	22	
23	40 - 60	0.008-0.012	0.015-0.02	0.035-0.04	0.075-0.085	0.095-0.105	0.15-0.16	23	
24	40 - 60	0.008-0.012	0.015-0.02	0.035-0.04	0.075-0.085	0.095-0.105	0.15-0.16	24	
31								31	
32								32	
41	40 - 80	0.003-0.006	0.008-0.012	0.01-0.018	0.025-0.03	0.055-0.06	0.075-0.085	41	
42								42	
51	30 - 50	0.008-0.012	0.015-0.02	0.035-0.04	0.075-0.085	0.095-0.105	0.11-0.13	51	
52								52	
53								53	
61	70 - 150	0.15-0.25	0.035-0.045	0.055-0.065	0.11-0.13	0.15-0.17	0.18-0.22	61	
62								62	
63	70 - 150	0.15-0.25	0.035-0.045	0.055-0.065	0.11-0.13	0.15-0.17	0.18-0.22	63	
64	70 - 150	0.15-0.25	0.035-0.045	0.055-0.065	0.11-0.13	0.15-0.17	0.18-0.22	64	
71	100 - 160	0.025-0.035	0.045-0.055	0.075-0.085	0.15-0.17	0.22-0.26	0.30-0.34	71	
72	100 - 160	0.025-0.035	0.045-0.055	0.075-0.085	0.15-0.17	0.22-0.26	0.30-0.34	72	
73	60 - 130	0.02-0.03	0.035-0.045	0.055-0.065	0.11-0.13	0.16-0.20	0.22-0.26	73	
74								74	
81								81	
82								82	
83								83	
91								91	
92								92	
93	40 - 60	0.008-0.012	0.015-0.02	0.035-0.04	0.075-0.085	0.095-0.105	0.15-0.16	93	
94	40 - 60	0.008-0.012	0.015-0.02	0.035-0.04	0.075-0.085	0.095-0.105	0.15-0.16	94	

Указаны ориентировочные значения.
The indicated values are a guideline.

Твердосплавные центровочные сверла
Solid carbide spotting drills

VHM
CAR

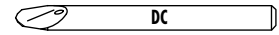

h6

C

C315VS

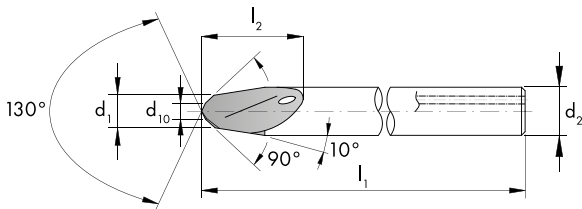
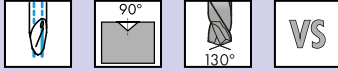

C315VS



$\emptyset d_1$	l_1 mm	l_2 mm	d_2 h6 mm	d_{10} mm	
1.4	40	6	3	0.5	2
2	40	6.2	3	1	2
3	40	6.3	3	1.5	2
4	50	8	4	2	2
6	60	12	6	3	2
8	70	16	8	4	2

ID

- 182872
- 182873
- 182874
- 190331
- 190332
- 190333

Твердосплавные спиральные сверла
Solid carbide twist drills

VHM
CAR

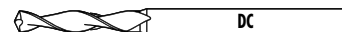

h6

FZ

FZ315VS

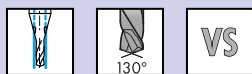

FZ315VS

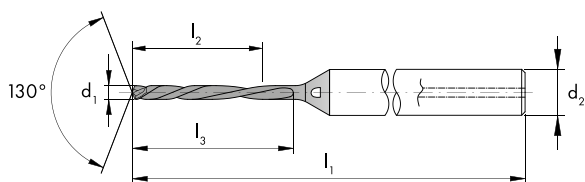

FZ315VS

FZ315VS



Ø d ₁	D ₁ mm	l ₁ mm	l ₂ mm	l ₃ mm	d ₂ h6 mm	
0.58	M0.8	42	4.6	5.7	3	2
0.59	S0.8	42	4.7	5.8	3	2
0.65	M0.9	45	5.2	6.4	3	2
0.67	S0.9	45	5.4	6.6	3	2
0.7	M1	45	5.6	6.9	3	2
0.74	S1	45	5.9	7.3	3	2
0.9	M1.2	45	7.2	8.8	3	2
0.94	S1.2	48	7.5	9.2	3	2
1.05	M1.4	48	8.4	10.3	3	2
1.09	S1.4	48	8.7	10.7	3	2
1.19	M1.6	48	9.5	11.7	3	2
1.39	M1.8	52	11.1	13.6	4	2
1.54	M2	55	12.3	15.1	4	2
1.98	M2.5	55	15.8	19.4	4	2

ID

- 182863
- 188023
- 182864
- 188024
- 182865
- 188025
- 182866
- 188026
- 182867
- 188027
- 182868
- 182869
- 182870
- 182871

Ø d ₁	D ₁ mm	l ₁ mm	l ₂ mm	l ₃ mm	d ₂ h6 mm	
2.15	UNC4	63	12.9	19.4	4	2
2.45	M3	65	14.7	22.1	4	2
2.65	UNC6	68	15.9	23.9	4	2
2.85	M3.5	68	17.1	25.7	4	2
3.25	M4	74	19.5	29.3	6	2
3.95	UNF10	78	23.7	35.6	6	2
4.1	M5	80	24.6	36.9	6	2
4.9	M6	84	29.4	44.1	6	2
5	UNC1/4	84	30	45	6	2
5.4	UNF1/4	88	32.4	48.6	6	2

ID

- 190326
- 190321
- 190327
- 190322
- 190323
- 190329
- 190324
- 190325
- 190328
- 190330

Твердосплавные спиральные сверла
Solid carbide twist drills

VHM
CAR

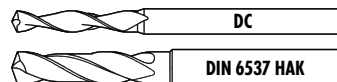

HBK
HEK

sur demande
auf Anfrage
on request
su richiesta
sobre pedido
no заказ

							F313VS	F285VS	F286VS				
<p>F313VS</p> <p>11 12 13 14 15 21 22 23 24 41 61 63 71 72 73 74</p> <p>F285VS F286VS</p> <p>11 12 13 14 15 21 22 23 24 41 51 61 71 72 73 74 93 94</p>													
$\emptyset d_1$ (h ₇)	d_2 (h ₈) mm	l_1 mm	l_2 mm				ID						
0.88	3	38	8	2	M1		● 158515						
0.9	3	38	10	2	*M1.2		● 159419						
1.08	3	38	10	2	M1.2		● 158516						
1.25	3	38	12	2	M1.4		● 158517						
1.45	3	38	12	2	M1.6		● 158518						
1.65	3	38	12	2	M1.8		● 158519						
1.8	3	38	12	2	M2		● 158520						
1.95	3	38	12	2	UNC2-56		● 158521						
2.3	3	38	16	2	M2.5		● 158522						
2.55	3	38	16	2	UNC4-40		● 158523						
2.8	3	38	16	2	M3		● 158524						
*GWi5000													
$\emptyset d_1$ (m ₇)	d_2 (h ₈) mm	l_1 mm	l_2 mm	l_3 mm			ID						
3.25	6	62	20	14	2	M3.5	● 158527						
3.7	6	62	20	14	2	M4	● 158528						
4.65	6	66	24	17	2	M5	● 158532						
5.55	6	66	28	20	2	M6	● 158534						
7.4	8	79	41	29	2	M8	● 158540						
9.3	10	89	47	35	2	M10	● 158544						
11.2	12	102	55	40	2	M12	● 158546						
$\emptyset d_1$ (m ₇)	d_2 (h ₈) mm	l_1 mm	l_2 mm	l_3 mm			ID						
3.3	6	66	28	23	2	M4	● 160989						
4.2	6	74	36	29	2	M5	● 160990						
5	6	82	44	35	2	M6	● 160991						
6.8	8	91	53	43	2	M8	● 160992						
8.5	10	103	61	49	2	M10	● 160993						
10.2	12	118	71	56	2	M12	● 160994						



A large, detailed image of a metal drill bit is centered vertically, extending from the top to the bottom of the page. The bit is shown in a dynamic, slightly blurred state, as if it is being rotated or moved through a medium. The background is a deep blue, textured surface that resembles water with white foam and splashes, creating a sense of motion and depth. The lighting highlights the metallic sheen and the sharp edges of the drill bit's flutes.

**Z | CHALLENGING
THREADING**





Плашкодержатели и воротки для метчиков

Die stocks and tap wrenches

<p>D5810- Плашкодержатели для круглых плашек по DIN EN 22568, DIN EN 24230, DIN EN 24231, DIN EN 40434 Die stocks for round dies to DIN EN 22568, DIN EN 24230, DIN EN 24231, DIN EN 40434</p> <p>D5820- Воротки для метчиков, регулируемые DIN 1814 Tap wrenches, adjustable DIN 1814</p>										<p>D5810-</p> 	<p>D5820-</p> 
DIN EN	M	MF	UNC	UNF	UNEF UNS UN	W	G (BSP)	NPT NPTF R (BSPT)	ID		
No D5810- Ø	Ø	Ø	Ø	Ø	Ø	Ø	Ø	Ø			
1 16 x 5	1 - 2.6	2 - 2.6	No. 1 - 4	No. 1 - 4		1/16" - 3/32"			● 170712		
2 20 x 5	3 - 4	3 - 6	No 5	No 5 - 6		1/8"			● 170713		
3 20 x 7	4.5 - 6		No 6 - 1/4"	No 8 - 1/4"	No 12 - 1/4"	5/32" - 1/4"			● 170714		
4 25 x 9	7 - 9	7 - 9	5/16"	5/16"	5/16"	5/16"		1/16"	● 170715		
5 30 x 11	10 - 11	10 - 11	3/8" - 7/16"	3/8" - 7/16"	3/8" - 7/16"	3/8" - 7/16"	1/8"	1/8"	● 170716		
6 38 x 10		12 - 15		1/2" - 9/16"	1/2" - 9/16"		1/4"		● 170717		
7 38 x 14	12 - 14		1/2" - 9/16"			1/2" - 9/16"		1/4"	● 170718		
8 45 x 14		16 - 20		5/8" - 3/4"	5/8" - 13/16"		3/8" - 1/2"	3/8"	● 170719		
9 45 x 18	16 - 20		5/8" - 3/4"			5/8" - 3/4"		1/2"	● 170720		
10 55 x 16		22 - 26		7/8" - 1"	7/8" - 1"		5/8" - 3/4"		● 170721		
11 55 x 22	22 - 24		7/8" - 1"			7/8" - 1"		3/4"	● 170722		
12 65 x 18		*27 - 36		1 1/8" - 1 3/8"	1 1/16" - 1 3/8"		7/8" - 1"		● 170723		
13 65 x 25	27 - 36		1 1/8" - 1 3/8"			1 1/8" - 1 3/8"		1"	● 170724		
14 75 x 20		38 - 42		1 1/2"	1 7/16" - 1 1/2"		1 1/8" - 1 1/4"		● 170725		
15 75 x 30	39 - 42		1 1/2"			1 1/2" - 1 5/8"			● 170726		
16 90 x 22		45 - 52			1 3/4" - 2"		1 3/8" - 1 3/4"		● 170727		
17 90 x 36	45 - 52		1 3/4" - 2"			1 3/4" - 2"			● 170728		
18 105 x 22		55 - 65					2" - 2 1/4"		● 170729		
<p>*Для шага 3 мм используйте No13. For 3 mm pitches use No. 13.</p>											
No D5820-	a mm									ID	
0	1.9 - 3									● 170730	
1	2.5 - 5.5									● 170731	
2	4.3 - 8									● 170732	
3	5.5 - 12									● 170733	
4	9.5 - 15.5									● 170734	
5	12.5 - 22.4									● 170735	

Удлинитель для метчиков

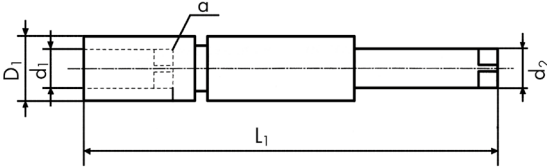
Tap extension sleeves

D5830- Удлинители для метчиков по ~DIN 377 Tap extension sleeves ~DIN 377		D5840- Удлинители для метчиков Tap extension sleeves		D5830-	D5840-	
						
No D5830-	a mm	L ₁ mm	D ₁ mm	ID		
1	2.1	60	6	● 110571		
2	2.24	70	6	● 110572		
3	2.4	70	6	● 110573		
4	2.5	80	7	● 110574		
5	2.8	90	7	● 110575		
6	3	90	7	● 110579		
7	3.15	95	7	● 110580		
8	3.4	95	8	● 110581		
9	3.55	100	8	● 118706		
10	3.8	100	9	● 118707		
11	4	105	10	● 118708		
12	4.3	105	10	● 118709		
13	4.5	105	10	● 118710		
14	4.9	110	10	● 118711		
15	5	110	11	● 118712		
16	5.5	115	12	● 118713		
17	5.6	110	12	● 118714		
18	6.2	120	14	● 118715		
19	6.3	120	14	● 118716		
20	7	125	15	● 118717		
21	7.1	120	15	● 118718		
22	7.5	120	15	● 118719		
23	8	125	17	● 118720		
24	9	130	19	● 118721		
25	10	140	21	● 110562		
26	11	150	23	● 110563		
27	11.2	145	23	● 110564		
28	12	155	25	● 110565		
29	12.5	160	25	● 110566		
30	14	165	28	● 110567		
31	14.5	175	29	● 110568		
32	16	180	30	● 110569		
33	18	200	33	● 110570		
34	20	220	36	● 110576		
35	22	220	40	● 110577		
36	22.4	240	40	● 110578		
No D5840-	a mm	L ₁ mm	d ₂ mm	d ₁ mm	D ₁ mm	ID
10	2.7	130	6	3.5	7.5	● 169928
11	3.4	130	6	4.5	8.5	● 169929
1	4.9	130	6	6	12	● 142137
2	5.5	130	7	7	13	● 142138
3	6.2	130	8	8	13	● 142139
4	7	130	9	9	17	● 142140
5	8	130	10	10	17	● 142141
6	9	130	11	11	17	● 142142
7	9	130	12	12	20	● 142143
8	11	130	14	14	20	● 142144
9	12	130	16	16	25	● 142145



ОСВОЙТЕ САМЫЕ МАЛЕНЬКИЕ И ТОЧНЫЕ РЕЗЬБОВЫЕ СОЕДИНЕНИЯ

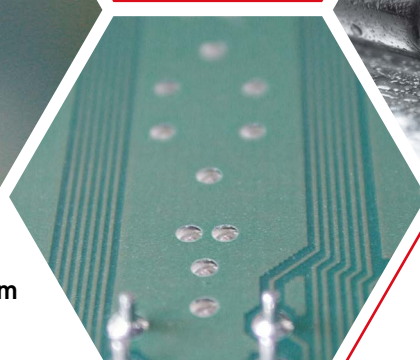
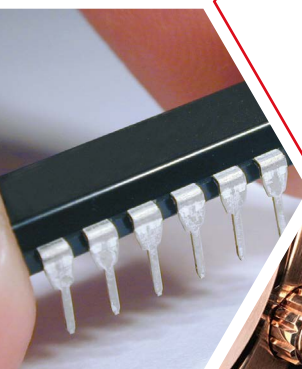

MASTER THE SMALLEST AND MOST PRECISE THREADED CONNECTIONS

nano



СПЕЦИАЛЬНЫЕ ИНСТРУМЕНТЫ ПО ЗАПРОСУ

Некоторые процессы требуют специальных инструментов. DC SWISS может создать индивидуальные метчики в соответствии с вашими требованиями.

БЛАГОДАРЯ НАШЕМУ ОПЫТУ И ЗНАНИЯМ МЫ МОЖЕМ СОЗДАТЬ ПО ЗАКАЗУ ИНСТРУМЕНТ, ОТВЕЧАЮЩИЙ САМЫМ ВЫСОКИМ ТРЕБОВАНИЯМ.

Для того, чтобы Вы могли создавать самые смелые и разнообразные сборки, лучше всего подходящие для ситуации, DC SWISS предлагает Вам доступ к своему обширному опыту. Инструменты - это, в конце концов, предмет первой необходимости. Он должен подходить к любой конфигурации, любому материалу и любой технологии производства. Формы и размеры больше не являются ограничивающим фактором. DC SWISS традиционно разрабатывает специальные инструменты, потому что индивидуальные заказы становятся все более распространенным явлением.

**МЕДИЦИНСКАЯ
MEDICAL**

**АЭРОКОСМИЧЕСКАЯ
AEROSPACE**

**СПЕЦИАЛЬНЫЕ РЕШЕНИЯ
CUSTOMISED SOLUTIONS**



SPECIAL TOOLS ON DEMAND

Some processes require special on demand tools. DC SWISS can create custom-made threading tools to meet your requirements.

With our expertise, we can create on demand tools that meet the highest market requirements.

To enable you to create the most audacious and varied assemblies that are best suited to every situation, DC SWISS offers you access to its extensive expertise. Tools are, after all, essential items. They need to adapt to every configuration, every material and all production techniques. Shapes and sizes are no longer constraining factors. DC SWISS develops tools as a matter of course, because custom-made orders are becoming increasingly commonplace.

АВТОМОБИЛЬНАЯ
AUTOMOTIVE

ЧАСОВАЯ
WATCHMAKING



**НАРЕЗАНИЕ РЕЗЬБЫ И ОБРАЗОВАНИЕ
РАСКАТНИКАМИ НАНО
THREAD CUTTING & THREAD FORMING NANO**

nano



ХАРАКТЕРИСТИКИ — SPECIFICATIONS

TAN



TAZ



FA



- Заготовки HSSE-PM премиум-качества
- Точность и воспроизводимость инструмента при изготовлении в одном зажиме
- Специальная чистка или полировка 100% инструментов
- Оптимальное покрытие, адаптированное к каждой геометрии

- Top quality HSSE-PM raw material
- Accuracy and repeatability of the tool by manufacturing in a single clamping operation
- Cleaning, brushing or polishing of 100 % of the tools
- Optimal coating adapted to each geometry

TAN40



- Для сквозных отверстий $< 2 \times D$

- For through holes $< 2 \times D$

TAN50



- Для глухих отверстий $< 2 \times D$

- For blind holes $< 2 \times D$

Применение

Для легкообрабатываемых материалов, сталей, латуни, желтого золота, серебра

Application

For easy-to-machine materials, steels, brass, yellow gold, silver

TAN40VS

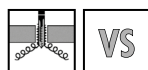

- Универсальное износостойкое покрытие "VS" для длительного срока службы инструмента в серийном производстве

- Versatile "VS" wear-protective coating for long tool life in series production

TAN50VS

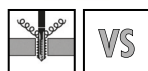

- Для глухих отверстий $< 2 \times D$

- For blind holes $< 2 \times D$

Применение

Для вязких материалов, таких как никелевые сплавы, титановые сплавы, легированные драгоценные металлы

Application

For tough materials such as nickel alloys, titanium alloys, alloyed precious materials

- Специальное покрытие "VS" последнего поколения, адаптированное к геометрии инструмента

- Specific "VS" coating of the latest generation adapted to the geometry of the tool



ХАРАКТЕРИСТИКИ — SPECIFICATIONS

FA80VS



- Для сквозных и глухих отверстий $< 2.5 \times D$
- Со сверхкороткой заходной частью $1.5 \times P$ (для резьбы вплотную к дну отверстия)

- For through and blind holes $< 2.5 \times D$
- With extra-short chamfer $1.5 \times P$ (for threads close to the bottom of the core hole)

FA83VS



- Для сквозных и глухих отверстий $< 2.5 \times D$
- С короткой заходной частью $2.5 \times P$

- For through and blind holes $< 2.5 \times D$
- With short chamfer $2.5 \times P$

Применение

- Для любого типа материала с удлинением $> 5\%$
- Полигон, с 4 выступами от $\varnothing 0.5$ мм
- Улучшенная прочность резьбы на растяжение

Application

- For any type of material with an elongation $> 5\%$
- Polygon made up of 4 lobes from $\varnothing 0.5$ mm
- Improved thread tensile strength



- Универсальное износостойкое покрытие "VS" для длительного срока службы инструмента в серийном производстве

- Versatile "VS" wear-protective coating for long tool life in series production

ХАРАКТЕРИСТИКИ — SPECIFICATIONS

CMS



CFA



- Специально подобранная марка твердого сплава сочетает твердость и прочность на скручивание
- Точность и повторяемость инструмента изготавливаемого за один установ
- Непревзойдённое качество поверхности

- Hard Metal grade suitable for its hardness and torsional strength
- Precision and repeatability of the tool by manufacturing in a single clamping operation
- Unsurpassed surface quality

CMS50



CMS50VS



- Для сквозных и глухих отверстий < 3 x D
- С революционной геометрией заходной части для оптимального врезания

- For through and blind holes < 3 x D
- With a revolutionary chamfer geometry for optimal material penetration

Применение

- Для хрупких материалов, таких как латунь с короткой стружкой, серый чугун, бронза БрБ2, алюминиевый сплав с Si > 5%
- Специальное покрытие "VS" последнего поколения, адаптированное к геометрии инструмента

Application

- For brittle materials like short chip brass, grey cast iron, Cube2, aluminium alloy with Si > 5 %
- Specific "VS" coating of the latest generation adapted to the geometry of the tool



CFA80VS



- Для сквозных и глухих отверстий < 2.5 x D
- Со сверхкороткой заходной частью 1.5 x P (для резьбы у дна отверстия)

- For through and blind holes < 2.5 x D
- With extra-short chamfer 1.5 x P (for threads close to the bottom of the core hole)

CFA83VS



- Для сквозных и глухих отверстий < 2.5 x D
- С короткой заходной частью 2.5 x P

- For through and blind holes < 2.5 x D
- With short chamfer 2.5 x P

Применение

- Для всех типов цветных металлов с удлинением > 3%
- Для таких материалов, как: алюминий и медные сплавы, желтое и красное золото, серебро и др
- Универсальное износостойкое покрытие "VS" для длительного срока службы инструмента в серийном производстве

Application

- For any type of non-ferrous material with an elongation > 3 %
- For materials such as: aluminium and copper alloys, yellow and red gold, silver, etc
- Versatile "VS" wear-protective coating for long tool life in series production



КОДИРОВКА – CODIFICATION

DC Машинные метчики nano

DC Machine taps nano

Пример - Example

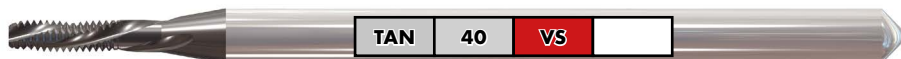

Нормальные материалы	Normal materials	TAN	
Вязкие материалы	Tough materials	TAZ	
латунь	Brass	CMS	
< 27° Левые спиральные канавки	< 27° left-hand spiral flutes		40
< 27° правые спиральные канавки	< 27° right-hand spiral flutes		50
DC "VS" износостойкое покрытие общего назначения	VS wear-protective coating, general		VS
Специальное исполнение	Special execution		SP

Для использования согласно таблице применения для метчиков DC nano

General dimensions as per DC standards
For use as per DC application chart for DC taps nano

DC Машинные раскатники nano

DC Machine thread formers nano

Пример - Example

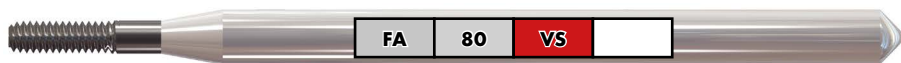

Раскатники nano из PM	Thread formers nano in PM	FA	
Твердосплавные раскатники nano	Thread formers nano in solid carbide	CFA	
Заходная часть форма E (1.5 - 2 нитки)	Lead form E (1.5 - 2 chamfered threads)		80
Заходная часть форма C (2 - 3 нитки)	Lead form C (2 - 3 chamfered threads)		83
DC "VS" износостойкое покрытие общего назначения	VS wear-protective coating, general		VS
Специальное исполнение	Special execution		SP

Для использования согласно таблице применения для раскатников DC nano.

General dimensions as per DC standards
For use as per DC application chart for DC thread formers nano

ПИКТОГРАММЫ — PICTOGRAPHS



Для групп материалов согласно таблице (DC).
For material groups as per (DC) application chart

12	
1.0037	Si37-2 (S235JR)
1.0050	Si50-2 (E295)
1.0060	Si60-2 (E335)
1.5919	15CrNi6
1.7131	16MnCr5

22	
1.4301	X5CrNi18-10
1.4406	X2CrNiMoN17-12-2
1.4435	X2CrNiMo18-14-3
1.4541	X6CrNiTi18-10
1.4571	X6CrNiMoTi17-12-2



Усиленный хвостовик по DIN 371
Reinforced shank as per DIN 371



Усиленный хвостовик по стандарту DC
Reinforced shank as per DC standards



Порошковая быстрорежущая сталь HSSE-PM
HSSE-PM



Твердосплавные
Solid carbide



Количество режущих кромок (Z)
Number of flutes (Z)



Левые спиральные канавки 20°
20° left-hand spiral flutes



Правые спиральные канавки 25°
25° right-hand spiral flutes



Раскатчик
Thread former



Сквозные отверстия < 2 x D, длинностружечные материалы
Through hole < 2 x D, long chipping materials



Глухие отверстия < 2 x D, длинностружечные материалы
Blind hole < 2 x D, long chipping materials



Сквозные/глухие отверстия < 2.5 x D
Through / blind hole < 2.5 x D



Сквозные/глухие отверстия < 3 x D, короткостружечные материалы
Through / blind hole < 3 x D, short chipping materials



Заходная часть 2 - 3 нитки, форма C
2 - 3 chamfered threads, lead form C



Заходная часть 3.5 - 5 нитки, форма D
3.5 - 5 chamfered threads, form D



Заходная часть 1.5 - 2 нитки, форма E
1.5 - 2 chamfered threads, lead form E



Класс точности 4H
Tolerance class 4H



Класс точности ISO 2 6H
Tolerance class ISO 2 6H



DC "VS" износостойкое покрытие общего назначения
DC "VS" wear-protective coating for general use



DC "VX" износостойкое покрытие для нержавеющей сталей и сплавов на основе никеля.
DC "VX" wear-protective coating for stainless steels and nickel alloys

- Складская позиция
Stock item
- Доступно в короткие сроки
Available at short notice
- * Доступно пока есть на складе
Available from stock, while stock lasts

**МАШИННЫЕ МЕТЧИКИ NANO
THREAD TAPS NANO**

DC. Классификация материалов

DC. Material classification









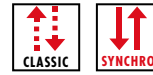





Группы материалов Material groups	Обозначение материалов	Material designation	Твердость Hardness (HВ)	Предел прочности Tensile strength Rm (N/mm ²)	Удлинение Elongation A (%)	
10 Стали Steels	11	Легко обрабатываемые стали	Free-cutting steels	< 200	< 700	< 10
	12	Структурные, цементируемые стали	Structural, cementation steels	< 200	< 700	< 30
	13	Углеродистые стали	Carbon steels	< 300	< 1000	< 20
	14	Легированные стали < 850 N/mm ²	Alloy steels < 850 N/mm ²	< 250	< 850	< 30
	15	Легированные стали закал./отп. > 850 - < 1150 N/mm ²	Alloy steels hard. / temp. > 850 - < 1150 N/mm ²	> 250	> 850	< 30
	16	Высокопрочные легированные стали ≤ 44 HRC	High tensile alloy steels ≤ 44 HRC	> 250	> 850	< 12
	17	Закалённые легированные стали > 44 - ≤ 54 HRC	Alloy steels tempered > 44 - ≤ 54 HRC	> 410	> 1400	< 2
	18	Закалённые легированные стали > 54 - ≤ 63 HRC	Alloy steels hardened > 54 - ≤ 63 HRC	> 560	> 1980	< 2
20 Нержавеющие стали Stainless steels	21	Легко обрабатываемые нержавеющие стали	Free machining stainless steels	< 250	< 850	< 25
	22	Аустенитные нержавеющие стали	Austenitic stainless steels	< 250	< 850	> 20
	23	Ферритные и мартенситные < 850 N/mm ²	Ferritic and martensitic < 850 N/mm ²	< 250	< 850	> 20
	24	Ферритные и мартенситные > 850 - < 1150 N/mm ²	Ferritic and martensitic > 850 - < 1150 N/mm ²	> 250	> 850	> 15
30 Чугун Cast iron	31	Чугун	Cast iron	< 250	< 850	< 10
	32	Высокопрочные и ковкий чугун	Spheroidal graphite + malleable cast iron	< 250	< 850	> 10
40 Титан Titanium	41	Чистый титан	Pure titanium	< 250	< 850	> 20
	42	Титановые сплавы	Titanium alloys	> 250	> 850	< 20
50 Никель Nickel	51	Никелевые сплавы 1 ≤ 850 N/mm ²	Nickel alloys 1 ≤ 850 N/mm ²	< 250	< 850	> 25
	52	Никелевые сплавы 2 > 850 - ≤ 1150 N/mm ²	Nickel alloys 2 > 850 - ≤ 1150 N/mm ²	> 250	> 850	< 25
	53	Никелевые сплавы 3 > 1150 - ≤ 1600 N/mm ²	Nickel alloys 3 > 1150 - ≤ 1600 N/mm ²	> 340	> 1150	< 20
60 Медь Copper	61	Медь чистая (электротехническая)	Pure copper (electrolytic copper)	< 120	< 400	> 12
	62	Короткостружечная латунь, фосфористая бронза	Short chip brass, phosphor bronze, gun metal	< 200	< 700	< 12
	63	Длинностружечная латунь	Long chip brass	< 200	< 700	> 12
	64	безсвинцовая латунь	Lead free brass	< 220	< 700	> 15
70 Алюминий Магний Aluminium Magnesium	71	Алюминий чистый	Al unalloyed	< 100	< 350	> 15
	72	Алюминиевые сплавы Si < 1.5 %	Al alloyed Si < 1.5 %	< 150	< 500	> 15
	73	Алюминиевые сплавы Si > 1.5 % - < 10 %	Al alloyed Si > 1.5 % - < 10 %	< 120	< 400	< 15
	74	Алюминиевые сплавы Si > 10 %, магниевые сплавы	Al alloyed Si > 10 %, Mg-alloys	< 120	< 400	< 10
80 Пластики Plastic compounds	81	Термопластики	Thermoplastics	-	-	-
	82	Дюропластики	Duroplastics	-	-	-
	83	Пластики армированные стекловолокном	Glass fibre reinforced plastics	-	-	-
90 Драгоценные металлы Precious metals	91	Желтое золото	Yellow gold	-	-	-
	92	Красное золото	Red gold	-	-	-
	93	Белое золото	White gold	-	-	-
	94	Серебро	Silver	-	-	-



				TAN				TAZ	
Характеристики Characteristics					 VS		 VS		 VS
Типы отверстий Hole type									
				TAN40	TAN40VS	TAN50	TAN50VS	TAZ40	TAZ40VS
M	4H / 6H	ISO DIN 14 ISO DIN 13	DC ~DIN 371	338	338	338	338	339	339
MF	4H / 6H	ISO DIN 13	DC ~DIN 371	341	341	341	341	342	342
UNC	2B	ASME B1.1	DC ~DIN 371	344	344	344	344	345	345
	3B	ASME B1.1	DC ~DIN 371	344	344	344	344	345	345
UNF	2B	ASME B1.1	DC ~DIN 371	347	347	347	347	348	348
	3B	ASME B1.1	DC ~DIN 371	347	347	347	347	348	348
S	NIHS	NIHS 06 - 10	DC	350	350	350	350	351	351
SF	NIHS	NIHS 06-10 Fine Thread	DC	353	353	353	353	354	354
SL	Safelock	SL 15 - 01	DC	356	356	356	356	357	357

Указатель — Машинные метчики nano
Directory — Machine taps nano



TAZ		CMS	
	 		 
			
			
TAZ50	TAZ50VS	CMS50	CMS50VS
339	339	340	340
342	342	343	343
345	345	346	346
345	345	346	346
348	348	349	349
348	348	349	349
351	351	352	352
354	354	355	355
357	357	358	358



PM

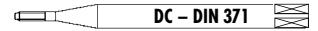

TAN

TAN40



62 63 91

TAN40VS



11 12 13 14 32 62
63 71 72 73 74 81
93

TAN50



62 63 91

TAN50VS



11 12 13 14 32 62
63 71 72 73 74 81
93

TAN40

TAN40VS

TAN50

TAN50VS

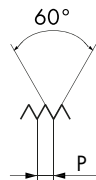
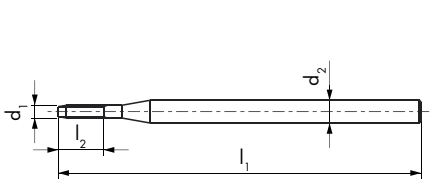

Ø d ₁ M	P mm	l ₁ mm	l ₂ mm	d ₂ mm		
0.5	0.125	25	1.5	2	3	Δ0.41
0.6	0.15	25	1.8	2	3	Δ0.5
0.7	0.175	25	2.1	2	3	Δ0.58
0.8	0.2	25	2.4	2	3	Δ0.66
0.9	0.225	25	2.7	2	3	Δ0.74
1	0.25	40	3.0	2.5	3	0.75
1.2	0.25	40	3.6	2.5	3	0.95
1.4	0.3	40	4.2	2.5	3	1.1

Δ 4H5H → 4H6H = +0.02 mm

ID	ID	ID	ID
● 161817	● 161748	● 161818	● 161749
● 152512	● 152511	● 152545	● 151766
● 152516	● 152515	● 152548	● 152547
● 152520	● 152519	● 152552	● 152551
● 152524	● 152523	● 152555	● 152554
● 152528	● 152527	● 152558	● 151557
● 152531	● 151463	● 152562	● 152561
● 152534	● 151756	● 152565	● 151757

Δ 4H5H → 4H6H = +0.02 mm

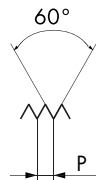
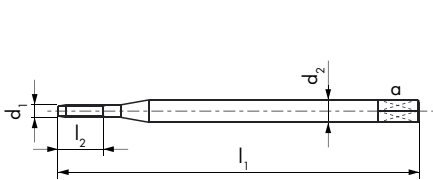

Ø d ₁ M	P mm	l ₁ mm	l ₂ mm	d ₂ mm	a mm		
1.6	0.35	40	4.8	2.5	3	1.25	
1.8	0.35	40	5.4	2.5	3	1.45	
2	0.4	45	8	2.8	2.1	3	1.6
2.3	0.4	45	9	2.8	2.1	3	1.9
2.5	0.45	50	10	2.8	2.1	3	2.05
2.6	0.45	50	10	2.8	2.1	3	2.15

ID	ID	ID	ID
● 152538	● 152537	● 152569	● 152568
● 193841	● 151461	● 193915	● 193952
● 152542	● 152541	● 152573	● 152572
● 193842	● 193878	● 193916	● 193953
● 193843	● 193879	● 193917	● 193954
● 193844	● 193880	● 193918	● 193955

TAZ

TAZ40



TAZ40VS

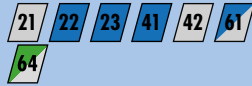

TAZ50



TAZ50VS

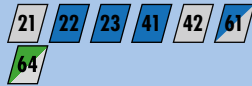

TAZ40

TAZ40VS

TAZ50

TAZ50VS

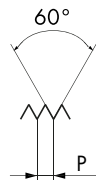
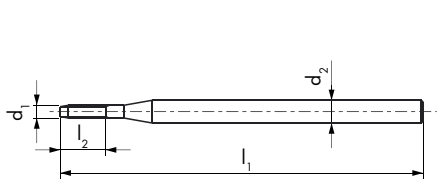

$\emptyset d_1$ M	P mm	l_1 mm	l_2 mm	d_2 mm		
0.5	0.125	25	1.5	2	3	$\Delta 0.41$
0.6	0.15	25	1.8	2	3	$\Delta 0.5$
0.7	0.175	25	2.1	2	3	$\Delta 0.58$
0.8	0.2	25	2.4	2	3	$\Delta 0.66$
0.9	0.225	25	2.7	2	3	$\Delta 0.74$
1	0.25	40	3	2.5	3	0.75
1.2	0.25	40	3.6	2.5	3	0.95
1.4	0.3	40	4.2	2.5	3	1.1

ID	ID	ID	ID
● 193994	● 194059	● 194119	● 194182
● 193995	● 194060	● 194120	● 194183
● 193996	● 194061	● 194121	● 194184
● 193997	● 194062	● 194122	● 194185
● 193998	● 194063	● 194123	● 194186
● 193999	● 194064	● 194124	● 183753
● 194000	● 194065	● 194125	● 194187
● 194001	● 194066	● 194126	● 194188

Δ 4H5H → 4H6H = +0.02 mm

Δ 4H5H → 4H6H = +0.02 mm

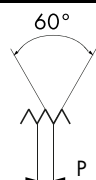
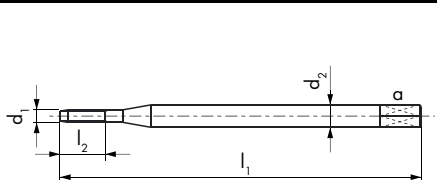

$\emptyset d_1$ M	P mm	l_1 mm	l_2 mm	d_2 mm	a mm		
1.6	0.35	40	4.8	2.5		3	1.25
1.8	0.35	40	5.4	2.5		3	1.45
2	0.4	45	8	2.8	2.1	3	1.6
2.3	0.4	45	9	2.8	2.1	3	1.9
2.5	0.45	50	10	2.8	2.1	3	2.05
2.6	0.45	50	10	2.8	2.1	3	2.15

ID	ID	ID	ID
● 194002	● 194067	● 194127	● 194189
● 194003	● 194068	● 194128	● 194190
● 194004	● 194947	● 194129	● 179266
● 194005	● 194069	● 194130	● 194191
● 194006	● 194070	● 194131	● 194192
● 194007	● 194071	● 194132	● 194193

CMS

CMS50



62 63 93

CMS50VS



31 62 63 73 74 83
93

CMS50

CMS50VS

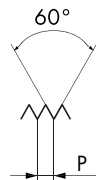
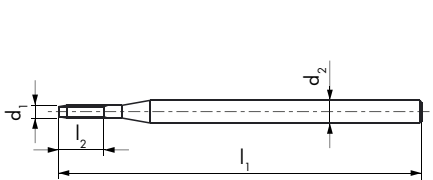

4H

4H

$\emptyset d_1$ M	P mm	l_1 mm	l_2 mm	d_2 h5 mm		
0.3	0.08	32	1.1	1.5	3	0.23
0.35	0.09	32	1.3	1.5	3	0.28
0.4	0.1	32	1.5	1.5	3	$\Delta 0.32$
0.5	0.125	32	1.8	1.5	3	$\Delta 0.41$
0.6	0.15	32	2.2	1.5	3	$\Delta 0.5$
0.7	0.175	32	2.6	1.5	3	$\Delta 0.58$
0.8	0.2	32	3	1.5	3	$\Delta 0.66$
0.9	0.225	32	3.3	1.5	3	$\Delta 0.74$
1	0.25	32	3.7	2	3	0.75
1.2	0.25	32	4.5	2	3	0.95
1.4	0.3	32	5.2	2	3	1.1

ID

ID

- | | |
|----------|----------|
| ● 193639 | ● 193702 |
| ● 193640 | ● 193703 |
| ● 193641 | ● 193704 |
| ● 193642 | ● 193705 |
| ● 193643 | ● 193706 |
| ● 193644 | ● 193707 |
| ● 193645 | ● 193708 |
| ● 193646 | ● 193709 |
| ● 193647 | ● 193710 |
| ● 193648 | ● 193711 |
| ● 193649 | ● 193712 |

Δ 4H5H → 4H6H = +0.02 mm

≥ M1 - ≤ M1.4

ISO 1
4H

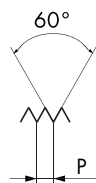
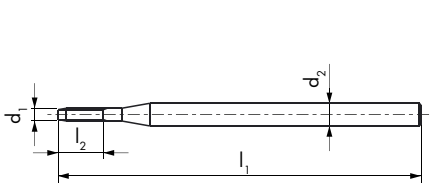

ISO 2
6H

ISO 2
6H

$\emptyset d_1$ M	P mm	l_1 mm	l_2 mm	d_2 h5 mm		
1.6	0.35	32	6	2	3	1.25
1.8	0.35	32	6.7	2	3	1.45
2	0.4	39	7.5	3	3	1.6
2.3	0.4	39	8.6	3	3	1.9
2.5	0.45	39	9.3	3	3	2.05
2.6	0.45	39	9.7	3	3	2.15

ID

ID

- | | |
|----------|----------|
| ● 193650 | ● 193713 |
| ● 193651 | ● 193714 |
| ● 193652 | ● 193715 |
| ● 193653 | ● 193716 |
| ● 193654 | ● 193717 |
| ● 193655 | ● 193718 |

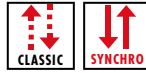

PM

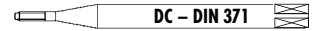

TAN

TAN40



62 63 91

TAN40VS



VS

11 12 13 14 32 62
63 71 72 73 74 81
93

TAN50



62 63 91

TAN50VS



VS

11 12 13 14 32 62
63 71 72 73 74 81
93

TAN40

TAN40VS

TAN50

TAN50VS

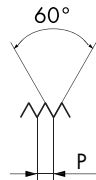
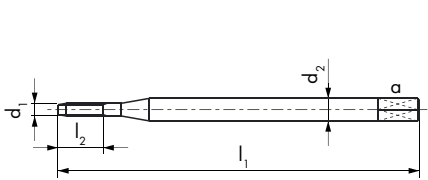

Ø d ₁ MF	P mm	l ₁ mm	l ₂ mm	d ₂ mm	a mm		
1.4	0.2	40	4.2	2.5		3	1.2
1.6	0.2	40	4.8	2.5		3	1.4
1.8	0.2	40	5.4	2.5		3	1.6
2	0.2	45	6	2.8	2.1	3	1.8
2	0.25	45	6	2.8	2.1	3	1.75
2.2	0.2	45	6.6	2.8	2.1	3	2
2.2	0.25	45	6.6	2.8	2.1	3	1.95
2.3	0.2	45	6.9	2.8	2.1	3	2.1
2.3	0.25	45	6.9	2.8	2.1	3	2.05
2.5	0.2	50	7.5	2.8	2.1	3	2.3
2.5	0.25	50	7.5	2.8	2.1	3	2.25

ID	ID	ID	ID
• 170390	• 193881	• 170393	• 156730
• 193845	• 193882	• 193919	• 193956
• 193846	• 193883	• 193920	• 180810
• 193847	• 193884	• 193921	• 184999
• 193848	• 193885	• 193922	• 182944
• 193849	• 193886	• 193923	• 179593
• 193850	• 193887	• 193924	• 193957
• 193851	• 193888	• 193925	• 193958
• 193852	• 193889	• 193926	• 193959
• 193853	• 193890	• 193927	• 193960
• 193854	• 193891	• 193928	• 193961

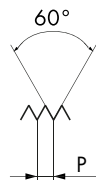
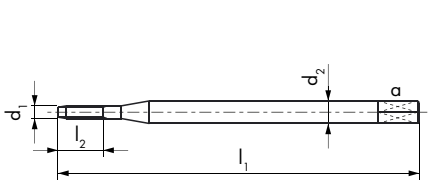

Ø d ₁ MF	P mm	l ₁ mm	l ₂ mm	d ₂ mm	a mm		
2.5	0.35	50	7.5	2.8	2.1	3	2.15
2.6	0.35	50	7.8	2.8	2.1	3	2.25

ID	ID	ID	ID
• 193855	• 193892	• 193929	• 193962
• 193856	• 193893	• 193930	• 193963



PM

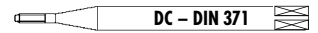

TAZ

TAZ40



TAZ40VS



VS

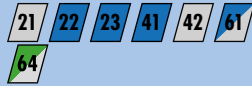

TAZ50



TAZ50VS



VS

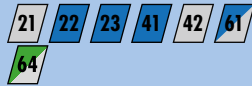

TAZ40

TAZ40VS

TAZ50

TAZ50VS

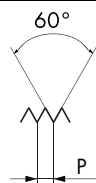
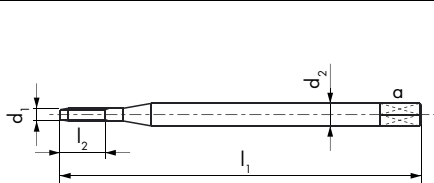

$\emptyset d_1$ MF	P mm	l_1 mm	l_2 mm	d_2 mm	a mm		
1.4	0.2	40	4.2	2.5		3	1.2
1.6	0.2	40	4.8	2.5		3	1.4
1.8	0.2	40	5.4	2.5		3	1.6
2	0.2	45	6	2.8	2.1	3	1.8
2	0.25	45	6	2.8	2.1	3	1.75
2.2	0.2	45	6.6	2.8	2.1	3	2
2.2	0.25	45	6.6	2.8	2.1	3	1.95
2.3	0.2	45	6.9	2.8	2.1	3	2.1
2.3	0.25	45	6.9	2.8	2.1	3	2.05
2.5	0.2	50	7.5	2.8	2.1	3	2.3
2.5	0.25	50	7.5	2.8	2.1	3	2.25

ID	ID	ID	ID
● 194008	● 194950	● 194133	● 194194
● 194009	● 194072	● 194134	● 181665
● 194010	● 194073	● 194135	● 190047
● 194011	● 194949	● 194136	● 194195
● 194012	● 194948	● 194137	● 185307
● 194013	● 194074	● 194138	● 194196
● 194014	● 194075	● 194139	● 194197
● 194015	● 194076	● 194140	● 194198
● 194016	● 194077	● 194141	● 194199
● 194017	● 194078	● 194142	● 194200
● 194018	● 194951	● 194143	● 194201

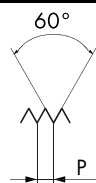
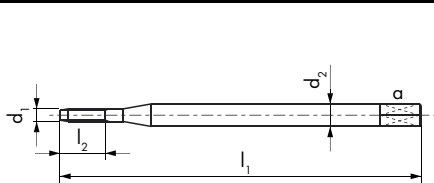

$\emptyset d_1$ MF	P mm	l_1 mm	l_2 mm	d_2 mm	a mm		
2.5	0.35	50	7.5	2.8	2.1	3	2.15
2.6	0.35	50	7.8	2.8	2.1	3	2.25

ID	ID	ID	ID
● 194019	● 194079	● 194144	● 194202
● 194020	● 194080	● 194145	● 194203



CMS

CMS50



62 63 93

CMS50VS



31 62 63 73 74 83 93

CMS50

CMS50VS

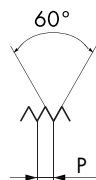
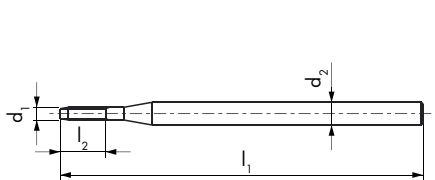

$\varnothing d_1$ MF	P mm	l_1 mm	l_2 mm	d_2 h5 mm		
1.4	0.2	32	5.2	2	3	1.2
1.6	0.2	32	6	2	3	1.4
1.8	0.2	32	6.7	2	3	1.6
2	0.2	39	7.5	3	3	1.8
2	0.25	39	7.5	3	3	1.75
2.2	0.2	39	8.2	3	3	2
2.2	0.25	39	8.2	3	3	1.95
2.3	0.2	39	8.6	3	3	2.1
2.3	0.25	39	8.6	3	3	2.05
2.5	0.2	39	9.3	3	3	2.3
2.5	0.25	39	9.3	3	3	2.25

ID

ID

- | | |
|----------|----------|
| ● 193656 | ● 193719 |
| ● 193657 | ● 193720 |
| ● 193658 | ● 193721 |
| ● 193659 | ● 193722 |
| ● 193660 | ● 193723 |
| ● 193661 | ● 193724 |
| ● 193662 | ● 193725 |
| ● 193663 | ● 193726 |
| ● 193664 | ● 193727 |
| ● 193665 | ● 193728 |
| ● 193666 | ● 193729 |

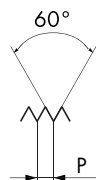
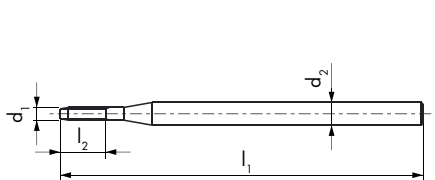

$\varnothing d_1$ MF	P mm	l_1 mm	l_2 mm	d_2 h5 mm		
2.5	0.35	39	9.3	3	3	2.15
2.6	0.35	39	9.7	3	3	2.25

ID

ID

- | | |
|----------|----------|
| ● 193667 | ● 193730 |
| ● 193668 | ● 193731 |



PM

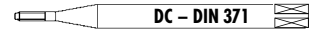

TAN

TAN										TAN40	TAN40VS	TAN50	TAN50VS			
TAN40 62 63 91																
TAN40VS VS 11 12 13 14 32 62 63 71 72 73 74 81 93																
TAN50 62 63 91																
TAN50VS VS 11 12 13 14 32 62 63 71 72 73 74 81 93																
										2B	2B	2B	2B			
Ø d₁	P	d₁	l₁	l₂	d₂	a				ID	ID	ID	ID			
UNC	TPI	mm	mm	mm	mm	mm										
1	64	1.85	40	5.6	2.5		3	1.45	●	193857	●	193894	●	193931	●	193964
2	56	2.18	45	9	2.8	2.1	3	1.75	●	193858	●	193895	●	193932	●	193965
3	48	2.51	50	10	2.8	2.1	3	2	●	193859	●	193896	●	193933	●	193966
										3B	3B	3B	3B			
Ø d₁	P	d₁	l₁	l₂	d₂	a				ID	ID	ID	ID			
UNC(J)	TPI	mm	mm	mm	mm	mm										
1	64	1.85	40	5.6	2.5		3	1.45	●	193860	●	193897	●	193934	●	193967
2	56	2.18	45	9	2.8	2.1	3	1.75	●	193861	●	193898	●	193935	●	193968
3	48	2.51	50	10	2.8	2.1	3	2	●	193862	●	193899	●	193936	●	193969



PM

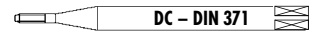

TAZ

TAZ40

TAZ40VS **VS**

TAZ50

TAZ50VS **VS**

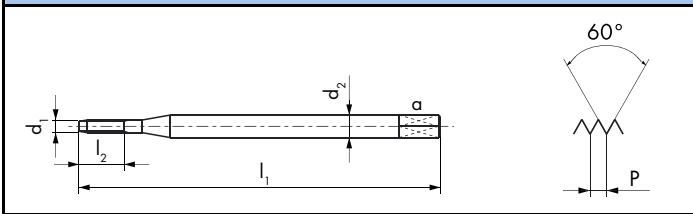
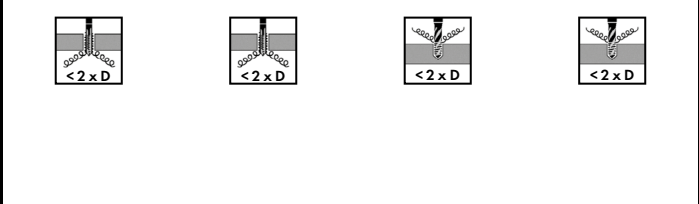
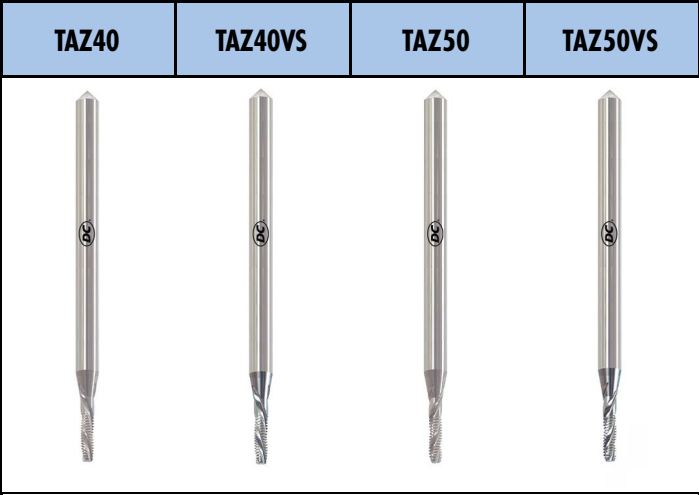

2B	2B	2B	2B

$\emptyset d_1$ UNC	P TPI	d_1 mm	l_1 mm	l_2 mm	d_2 mm	a mm		
1	64	1.85	40	5.6	2.5		3	1.45
2	56	2.18	45	9	2.8	2.1	3	1.75
3	48	2.51	50	10	2.8	2.1	3	2

ID	ID	ID	ID
194021	194081	194146	194204
194022	194082	194147	194205
194023	194083	194148	194206

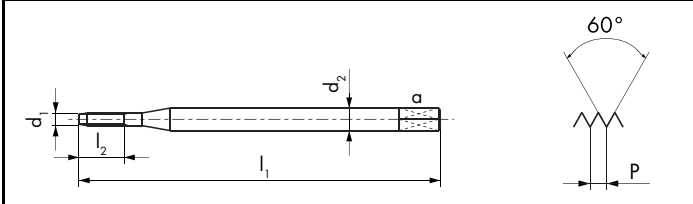

3B	3B	3B	3B
-----------	-----------	-----------	-----------

$\emptyset d_1$ UNC(J)	P TPI	d_1 mm	l_1 mm	l_2 mm	d_2 mm	a mm		
1	64	1.85	40	5.6	2.5		3	1.45
2	56	2.18	45	9	2.8	2.1	3	1.75
3	48	2.51	50	10	2.8	2.1	3	2

ID	ID	ID	ID
194024	194084	194149	194207
194025	194085	194150	194208
194026	194086	194151	194209



CMS

CMS50



62 63 93

CMS50VS



31 62 63 73 74 83
93

CMS50

CMS50VS

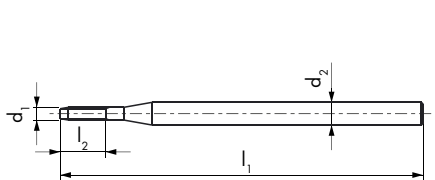

2B

2B

$\emptyset d_1$ UNC	P TPI	d_1 mm	l_1 mm	l_2 mm	d_2 h5 mm		
1	64	1.85	32	6.9	2	3	1.45
2	56	2.18	39	8.1	3	3	1.75
3	48	2.51	39	9.4	3	3	2

ID

ID

- | | |
|----------|----------|
| ● 193669 | ● 193732 |
| ● 193670 | ● 193733 |
| ● 193671 | ● 193734 |

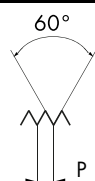
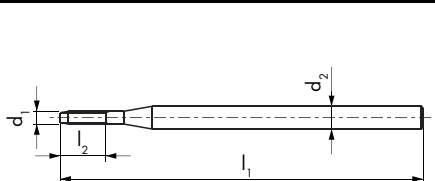

3B

3B

$\emptyset d_1$ UNC(J)	P TPI	d_1 mm	l_1 mm	l_2 mm	d_2 h5 mm		
1	64	1.85	32	6.9	2	3	1.45
2	56	2.18	39	8.1	3	3	1.75
3	48	2.51	39	9.4	3	3	2

ID

ID

- | | |
|----------|----------|
| ● 193672 | ● 193735 |
| ● 193673 | ● 193736 |
| ● 193674 | ● 193737 |

UNF ASME B1.1



PM

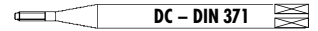

TAN

TAN40



62 63 91

TAN40VS



VS

11 12 13 14 32 62
63 71 72 73 74 81
93

TAN50



62 63 91

TAN50VS



VS

11 12 13 14 32 62
63 71 72 73 74 81
93

TAN40

TAN40VS

TAN50

TAN50VS

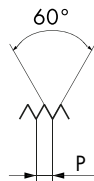
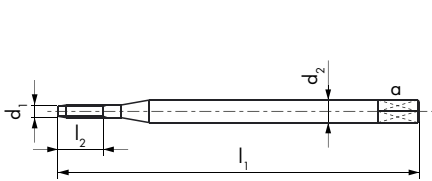

2B

2B

2B

2B

$\emptyset d_1$ UNF	P TPI	d_1 mm	l_1 mm	l_2 mm	d_2 mm	a mm		
0	80	1.52	40	4.6	2.5		3	1.2
1	72	1.85	40	5.6	2.5		3	1.5
2	64	2.18	45	9	2.8	2.1	3	1.8
3	56	2.51	50	10	2.8	2.1	3	2.1

ID

ID

ID

ID

● 193863	● 193900	● 193937	● 193970
● 193864	● 193901	● 193938	● 193971
● 193865	● 193902	● 193939	● 193972
● 193866	● 193903	● 193940	● 193973

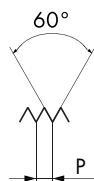
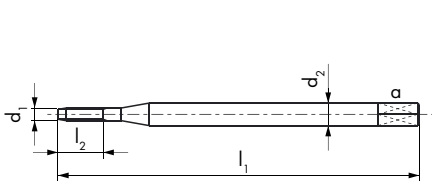

3B

3B

3B

3B

$\emptyset d_1$ UNF(J)	P TPI	d_1 mm	l_1 mm	l_2 mm	d_2 mm	a mm		
0	80	1.52	40	4.6	2.5		3	1.2
1	72	1.85	40	5.6	2.5		3	1.5
2	64	2.18	45	9	2.8	2.1	3	1.8
3	56	2.51	50	10	2.8	2.1	3	2.1

ID

ID

ID

ID

● 193867	● 193904	● 193941	● 193974
● 193868	● 193905	● 193942	● 193975
● 193869	● 193906	● 193943	● 193976
● 193870	● 193907	● 193944	● 193977



PM

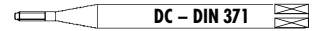

TAZ

TAZ40



TAZ40VS



VS

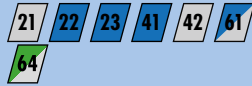

TAZ50



TAZ50VS



VS

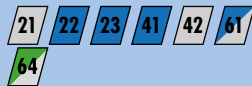

TAZ40

TAZ40VS

TAZ50

TAZ50VS

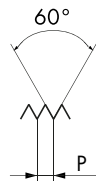
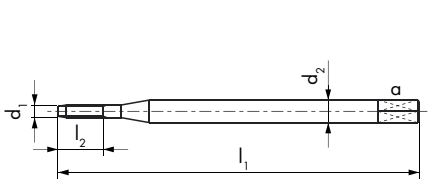

2B

2B

2B

2B

$\emptyset d_1$ UNF	P TPI	d_1 mm	l_1 mm	l_2 mm	d_2 mm	a mm		
0	80	1.52	40	4.6	2.5		3	1.2
1	72	1.85	40	5.6	2.5		3	1.5
2	64	2.18	45	9	2.8	2.1	3	1.8
3	56	2.51	50	10	2.8	2.1	3	2.1

ID

ID

ID

ID

● 194027	● 194087	● 194152	● 194210
● 194028	● 194088	● 194153	● 194211
● 194029	● 194089	● 194154	● 194212
● 194030	● 194090	● 194155	● 194213

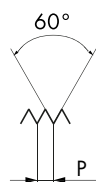
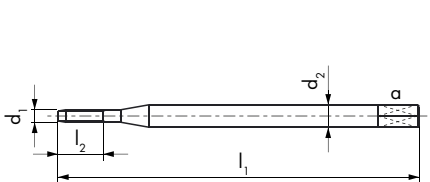

3B

3B

3B

3B

$\emptyset d_1$ UNF(J)	P TPI	d_1 mm	l_1 mm	l_2 mm	d_2 mm	a mm		
0	80	1.52	40	4.6	2.5		3	1.2
1	72	1.85	40	5.6	2.5		3	1.5
2	64	2.18	45	9	2.8	2.1	3	1.8
3	56	2.51	50	10	2.8	2.1	3	2.1

ID

ID

ID

ID

● 194031	● 194091	● 194156	● 194214
● 194032	● 194092	● 194157	● 194215
● 194033	● 194093	● 194158	● 194216
● 194034	● 194094	● 194159	● 194217



CMS

CMS50



62 63 93

CMS50VS



31 62 63 73 74 83 93

CMS50

CMS50VS

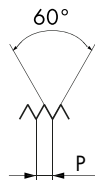
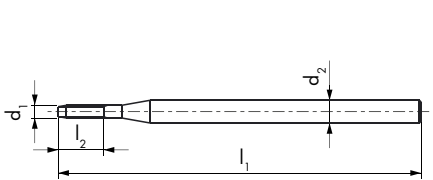

2B

2B

$\emptyset d_1$ UNF	P TPI	d_1 mm	l_1 mm	l_2 mm	d_2 h5 mm		
0	80	1.52	32	5.7	2	3	1.2
1	72	1.85	32	6.9	2	3	1.5
2	64	2.18	39	8.1	3	3	1.8
3	56	2.51	39	9.4	3	3	2.1

ID

ID

- | | |
|----------|----------|
| ● 193675 | ● 193738 |
| ● 193676 | ● 193739 |
| ● 193677 | ● 193740 |
| ● 193678 | ● 193741 |

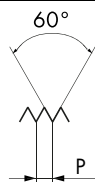
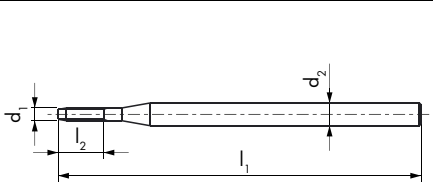

3B

3B

$\emptyset d_1$ UNF(J)	P TPI	d_1 mm	l_1 mm	l_2 mm	d_2 h5 mm		
0	80	1.52	32	5.7	2	3	1.2
1	72	1.85	32	6.9	2	3	1.5
2	64	2.18	39	8.1	3	3	1.8
3	56	2.51	39	9.4	3	3	2.1

ID

ID

- | | |
|----------|----------|
| ● 193679 | ● 193742 |
| ● 193680 | ● 193743 |
| ● 193681 | ● 193744 |
| ● 193682 | ● 193745 |

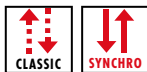

PM

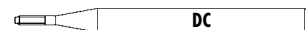

TAN							TAN40	TAN40VS	TAN50	TAN50VS
<p>TAN40 62 63 91</p> <p>TAN40VS VS 11 12 13 14 32 62 63 71 72 73 74 81 93</p> <p>TAN50 62 63 91</p> <p>TAN50VS VS 11 12 13 14 32 62 63 71 72 73 74 81 93</p>										
$\varnothing d_1$ S	P mm	l_1 mm	l_2 mm	d_2 mm			ID	ID	ID	ID
0.5	0.125	25	1.5	2	3	$\Delta 0.41$	● 161816	● 157021	● 159301	● 158384
0.6	0.15	25	1.8	2	3	$\Delta 0.5$	● 152510	● 152509	● 151567	● 152544
0.7	0.175	25	2.1	2	3	$\Delta 0.58$	● 152514	● 152513	● 151768	● 152546
0.8	0.2	25	2.4	2	3	$\Delta 0.66$	● 152518	● 152517	● 152550	● 152549
0.9	0.225	25	2.7	2	3	$\Delta 0.74$	● 152522	● 152521	● 152553	● 151563
1	0.25	40	3	2.5	3	$\Delta 0.82$	● 152526	● 152525	● 152557	● 152556
1.2	0.25	40	3.6	2.5	3	$\Delta 1.02$	● 152530	● 152529	● 152560	● 152559
1.4	0.3	40	4.2	2.5	3	$\Delta 1.18$	● 152533	● 152532	● 152564	● 152563
<p>Δ 4H5H \rightarrow 4H6H = +0.02 mm</p>										



PM



TAZ

TAZ40



TAZ40VS



VS

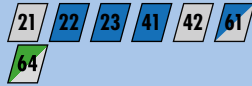

TAZ50



TAZ50VS



VS

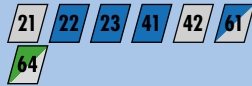

TAZ40

TAZ40VS

TAZ50

TAZ50VS

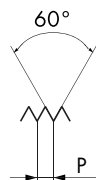
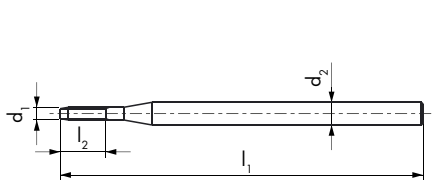

NIHS

NIHS

NIHS

NIHS

$\emptyset d_1$ S	P mm	l_1 mm	l_2 mm	d_2 mm		
0.5	0.125	25	1.5	2	3	$\Delta 0.41$
0.6	0.15	25	1.8	2	3	$\Delta 0.5$
0.7	0.175	25	2.1	2	3	$\Delta 0.58$
0.8	0.2	25	2.4	2	3	$\Delta 0.66$
0.9	0.225	25	2.7	2	3	$\Delta 0.74$
1	0.25	40	3	2.5	3	$\Delta 0.82$
1.2	0.25	40	3.6	2.5	3	$\Delta 1.02$
1.4	0.3	40	4.2	2.5	3	$\Delta 1.18$

Δ 4H5H \rightarrow 4H6H = +0.02 mm

ID

ID

ID

ID

193978	194043	194103	194168
193979	194044	194104	194169
193980	194045	194105	194170
193981	194046	194106	188515
193982	194047	194107	188521
193983	194048	194108	194171
193984	194049	194109	194172
193985	194050	194110	194173



CMS

CMS50



62 63 93

CMS50VS



31 62 63 73 74 83
93

CMS50

CMS50VS

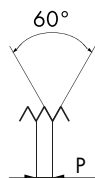
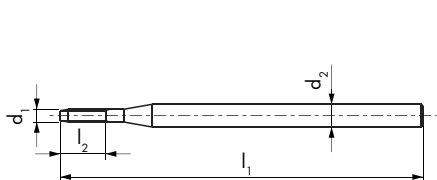

$\emptyset d_1$ S	P mm	l_1 mm	l_2 mm	d_2 h5 mm		
0.3	0.08	32	1.1	1.5	3	0.23
0.35	0.09	32	1.3	1.5	3	0.28
0.4	0.1	32	1.5	1.5	3	$\Delta 0.32$
0.5	0.125	32	1.8	1.5	3	$\Delta 0.41$
0.6	0.15	32	2.2	1.5	3	$\Delta 0.5$
0.7	0.175	32	2.6	1.5	3	$\Delta 0.58$
0.8	0.2	32	3	1.5	3	$\Delta 0.66$
0.9	0.225	32	3.3	1.5	3	$\Delta 0.74$
1	0.25	32	3.7	2	3	$\Delta 0.82$
1.2	0.25	32	4.5	2	3	$\Delta 1.02$
1.4	0.3	32	5.2	2	3	$\Delta 1.18$

ID

ID

● 178257	● 193683
● 178260	● 193684
● 178263	● 193685
● 178266	● 193686
● 178269	● 193687
● 178272	● 193688
● 178275	● 193689
● 178278	● 193690
● 178281	● 193691
● 178284	● 193692
● 178287	● 193693

Δ 4H5H \rightarrow 4H6H = +0.02 mm

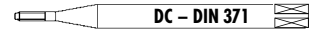

TAN

TAN40



62 63 91

TAN40VS



VS

11 12 13 14 32 62
63 71 72 73 74 81
93

TAN50



62 63 91

TAN50VS



VS

11 12 13 14 32 62
63 71 72 73 74 81
93

TAN40

TAN40VS

TAN50

TAN50VS

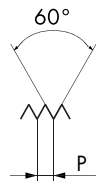
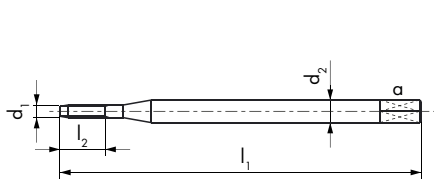

NIHS

NIHS

NIHS

NIHS

$\emptyset d_1$ SF	P mm	l_1 mm	l_2 mm	d_2 mm	a mm		
1.4	0.2	40	4.2	2.5		3	$\Delta 1.26$
1.6	0.2	40	4.8	2.5		3	$\Delta 1.46$
1.8	0.2	40	5.4	2.5		3	$\Delta 1.66$
2	0.2	45	6	2.8	2.1	3	$\Delta 1.86$
2.2	0.2	45	6.6	2.8	2.1	3	$\Delta 2.06$
2.2	0.25	45	6.6	2.8	2.1	3	$\Delta 2.02$
2.5	0.2	50	7.5	2.8	2.1	3	$\Delta 2.36$
2.5	0.25	50	7.5	2.8	2.1	3	$\Delta 2.32$

Δ 4H5H \rightarrow 4H6H = +0.02 mm

ID

ID

ID

ID

● 193833	● 170491	● 169767	● 170492
● 193834	● 193871	● 193908	● 193945
● 193835	● 193872	● 193909	● 193946
● 193836	● 193873	● 193910	● 193947
● 193837	● 193874	● 193911	● 193948
● 193838	● 193875	● 193912	● 193949
● 193839	● 193876	● 193913	● 193950
● 193840	● 193877	● 193914	● 193951

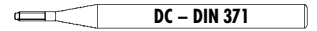

TAZ

TAZ40



TAZ40VS



VS

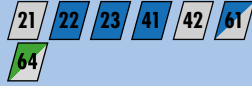

TAZ50



TAZ50VS



VS

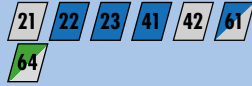

TAZ40

TAZ40VS

TAZ50

TAZ50VS

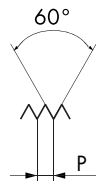
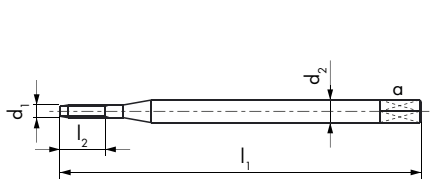

$\emptyset d_1$ SF	P mm	l_1 mm	l_2 mm	d_2 mm	a mm		
1.4	0.2	40	4.2	2.5		3	$\Delta 1.26$
1.6	0.2	40	4.8	2.5		3	$\Delta 1.46$
1.8	0.2	40	5.4	2.5		3	$\Delta 1.66$
2	0.2	45	6	2.8	2.1	3	$\Delta 1.86$
2.2	0.2	45	6.6	2.8	2.1	3	$\Delta 2.06$
2.2	0.25	45	6.6	2.8	2.1	3	$\Delta 2.02$
2.5	0.2	50	7.5	2.8	2.1	3	$\Delta 2.36$
2.5	0.25	50	7.5	2.8	2.1	3	$\Delta 2.32$

Δ 4H5H \rightarrow 4H6H = +0.02 mm

ID

ID

ID

ID

● 193986	● 194051	● 194111	● 194174
● 193987	● 194052	● 194112	● 194175
● 193988	● 194053	● 194113	● 194176
● 193989	● 194054	● 194114	● 194177
● 193990	● 194055	● 194115	● 194178
● 193991	● 194056	● 194116	● 194179
● 193992	● 194057	● 194117	● 194180
● 193993	● 194058	● 194118	● 194181



CMS

CMS50



62 63 93

CMS50VS



31 62 63 73 74 83
93

CMS50

CMS50VS

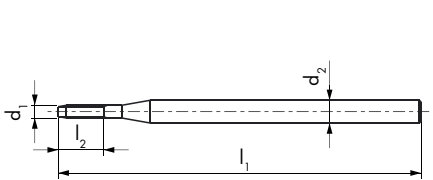

$\emptyset d_1$ SF	P mm	l_1 mm	l_2 mm	d_2 h5 mm		
1.4	0.2	32	5.2	2	3	$\Delta 1.26$
1.6	0.2	32	6	2	3	$\Delta 1.46$
1.8	0.2	32	6.7	2	3	$\Delta 1.66$
2	0.2	39	7.5	3	3	$\Delta 1.86$
2.2	0.2	39	8.2	3	3	$\Delta 2.06$
2.2	0.25	39	8.2	3	3	$\Delta 2.02$
2.5	0.2	39	9.3	3	3	$\Delta 2.36$
2.5	0.25	39	9.3	3	3	$\Delta 2.32$

ID	ID
● 180329	● 193694
● 193632	● 193695
● 193633	● 193696
● 193634	● 193697
● 193635	● 193698
● 193636	● 193699
● 193637	● 193700
● 193638	● 193701

Δ 4H5H \rightarrow 4H6H = +0.02 mm

TAN

TAN40



62 63 91

TAN40VS



11 12 13 14 32 62
63 71 72 73 74 81
93

TAN50



62 63 91

TAN50VS



11 12 13 14 32 62
63 71 72 73 74 81
93

TAN40

TAN40VS

TAN50

TAN50VS

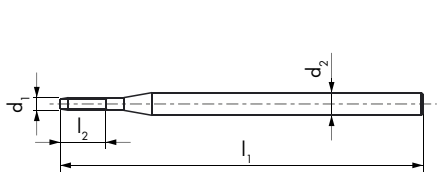

$\emptyset d_1$ SL	P mm	l_1 mm	l_2 mm	d_2 mm			ID	ID	ID	ID
0.5	0.1	25	1.5	2	3	0.46	● 600065	● 600073	● 600081	● 600089
0.6	0.125	25	1.8	2	3	0.55	● 600066	● 600074	● 600082	● 600090
0.7	0.15	25	2.1	2	3	0.64	● 600067	● 600075	● 600083	● 600091
0.8	0.15	25	2.4	2	3	0.74	● 600068	● 600076	● 600084	● 600092
0.9	0.175	25	2.7	2	3	0.83	● 600069	● 600077	● 600085	● 600093
1	0.2	40	3	2.5	3	0.92	● 600070	● 600078	● 600086	● 600094
1.2	0.2	40	3.6	2.5	3	1.12	● 600071	● 600079	● 600087	● 600095
1.4	0.25	40	4.2	2.5	3	1.3	● 600072	● 600080	● 600088	● 600096

TAZ

TAZ40



TAZ40VS

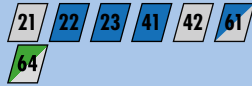

TAZ50



TAZ50VS

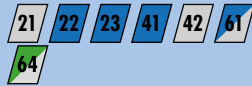

TAZ40

TAZ40VS

TAZ50

TAZ50VS

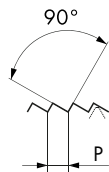
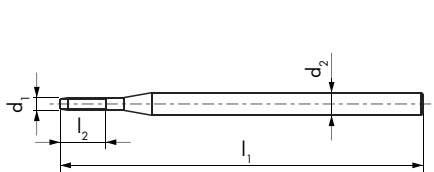

$\emptyset d_1$ SL	P mm	l_1 mm	l_2 mm	d_2 mm			ID	ID	ID	ID
0.5	0.1	25	1.5	2	3	0.46	● 600210	● 600218	● 600194	● 600202
0.6	0.125	25	1.8	2	3	0.55	● 600211	● 600219	● 600195	● 600203
0.7	0.15	25	2.1	2	3	0.64	● 600212	● 600220	● 600196	● 600204
0.8	0.15	25	2.4	2	3	0.74	● 600213	● 600221	● 600197	● 600205
0.9	0.175	25	2.7	2	3	0.83	● 600214	● 600222	● 600198	● 600206
1	0.2	40	3	2.5	3	0.92	● 600215	● 600223	● 600199	● 600207
1.2	0.2	40	3.6	2.5	3	1.12	● 600216	● 600224	● 600200	● 600208
1.4	0.25	40	4.2	2.5	3	1.3	● 600217	● 600225	● 600201	● 600209

CMS

CMS50



62 63 93

CMS50VS



31 62 63 73 74 83
93

CMS50

CMS50VS

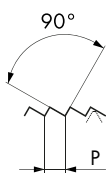
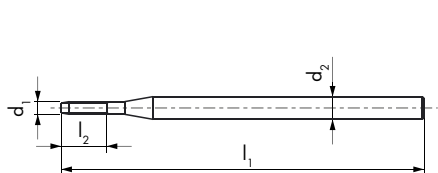

Ø d ₁ SL	P mm	l ₁ mm	l ₂ mm	d ₂ h5 mm		
0.3	0.06	32	1.1	1.5	3	0.27
0.35	0.06	32	1.3	1.5	3	0.32
0.4	0.08	32	1.5	1.5	3	0.36
0.5	0.1	32	1.8	1.5	3	0.46
0.6	0.125	32	2.2	1.5	3	0.55
0.7	0.15	32	2.6	1.5	3	0.64
0.8	0.15	32	3	1.5	3	0.74
0.9	0.175	32	3.3	1.5	3	0.83
1	0.2	32	3.7	2	3	0.92
1.2	0.2	32	4.5	2	3	1.12
1.4	0.25	32	5.2	2	3	1.3

ID

ID

● 600097	● 600226
● 600098	● 600227
● 600099	● 600228
● 600039	● 600229
● 600040	● 600230
● 600041	● 600231
● 600042	● 600232
● 600043	● 600233
● 600044	● 600234
● 600045	● 600235
● 600046	● 600236



H | PERSEVERING THREADING



**МАШИННЫЕ РАСКАТНИКИ NANO
THREAD FORMERS NANO**

DC. Классификация материалов

DC. Material classification

Группы материалов Material groups	Обозначение материалов	Material designation	Твердость Hardness (HВ)	Предел прочности Tensile strength Rm (N/mm ²)	Удлинение Elongation A (%)	
10 Стали Steels	11	Легко обрабатываемые стали	Free-cutting steels	< 200	< 700	< 10
	12	Структурные, цементуемые стали	Structural, cementation steels	< 200	< 700	< 30
	13	Углеродистые стали	Carbon steels	< 300	< 1000	< 20
	14	Легированные стали < 850 N/mm ²	Alloy steels < 850 N/mm ²	< 250	< 850	< 30
	15	Легированные стали закал./отп. > 850 - < 1150 N/mm ²	Alloy steels hard. / temp. > 850 - < 1150 N/mm ²	> 250	> 850	< 30
	16	Высокопрочные легированные стали ≤ 44 HRC	High tensile alloy steels ≤ 44 HRC	> 250	> 850	< 12
	17	Закалённые легированные стали > 44 - ≤ 54 HRC	Alloy steels tempered > 44 - ≤ 54 HRC	> 410	> 1400	< 2
	18	Закалённые легированные стали > 54 - ≤ 63 HRC	Alloy steels hardened > 54 - ≤ 63 HRC	> 560	> 1980	< 2
20 Нержавеющие стали Stainless steels	21	Легко обрабатываемые нержавеющие стали	Free machining stainless steels	< 250	< 850	< 25
	22	Аустенитные нержавеющие стали	Austenitic stainless steels	< 250	< 850	> 20
	23	Ферритные и мартенситные < 850 N/mm ²	Ferritic and martensitic < 850 N/mm ²	< 250	< 850	> 20
	24	Ферритные и мартенситные > 850 - < 1150 N/mm ²	Ferritic and martensitic > 850 - < 1150 N/mm ²	> 250	> 850	> 15
30 Чугун Cast iron	31	Чугун	Cast iron	< 250	< 850	< 10
	32	Высокопрочные и ковкий чугун	Spheroidal graphite + malleable cast iron	< 250	< 850	> 10
40 Титан Titanium	41	Чистый титан	Pure titanium	< 250	< 850	> 20
	42	Титановые сплавы	Titanium alloys	> 250	> 850	< 20
50 Никель Nickel	51	Никелевые сплавы 1 ≤ 850 N/mm ²	Nickel alloys 1 ≤ 850 N/mm ²	< 250	< 850	> 25
	52	Никелевые сплавы 2 > 850 - ≤ 1150 N/mm ²	Nickel alloys 2 > 850 - ≤ 1150 N/mm ²	> 250	> 850	< 25
	53	Никелевые сплавы 3 > 1150 - ≤ 1600 N/mm ²	Nickel alloys 3 > 1150 - ≤ 1600 N/mm ²	> 340	> 1150	< 20
60 Медь Copper	61	Медь чистая (электротехническая)	Pure copper (electrolytic copper)	< 120	< 400	> 12
	62	Короткостружечная латунь, фосфористая бронза	Short chip brass, phosphor bronze, gun metal	< 200	< 700	< 12
	63	Длинностружечная латунь	Long chip brass	< 200	< 700	> 12
	64	безсвинцовая латунь	Lead free brass	< 220	< 700	> 15
70 Алюминий Магний Aluminium Magnesium	71	Алюминий чистый	Al unalloyed	< 100	< 350	> 15
	72	Алюминиевые сплавы Si < 1.5 %	Al alloyed Si < 1.5 %	< 150	< 500	> 15
	73	Алюминиевые сплавы Si > 1.5 % - < 10 %	Al alloyed Si > 1.5 % - < 10 %	< 120	< 400	< 15
	74	Алюминиевые сплавы Si > 10 %, магниевые сплавы	Al alloyed Si > 10 %, Mg-alloys	< 120	< 400	< 10
80 Пластики Plastic compounds	81	Термопластики	Thermoplastics	-	-	-
	82	Дюропластики	Duroplastics	-	-	-
	83	Пластики армированные стекловолокном	Glass fibre reinforced plastics	-	-	-
90 Драгоценные металлы Precious metals	91	Желтое золото	Yellow gold	-	-	-
	92	Красное золото	Red gold	-	-	-
	93	Белое золото	White gold	-	-	-
	94	Серебро	Silver	-	-	-

МАШИННЫЕ РАСКАТНИКИ NANO — THREAD FORMERS NANO



Со страницы: From page:
M
MF
UNC
UNF
S
SF
SL

FA Нормальные материалы Normal materials		CFA Цветные материалы Non-ferrous materials	
363	363	370	370
364	364		
365	365	371	371
366	366	372	372
367	367	373	373
368	368		
369	369		
FA80VS	FA83VS	CFA80VS	CFA83VS

	Vc (m/min) Guide Line				
	\varnothing 0.3 - 1.4 mm	\varnothing 1.4 - 2.8 mm			
	С покрытием Coated	С покрытием Coated			
11	4 - 10	12 - 20			11
12	4 - 10	12 - 20			12
13	4 - 10	12 - 20			13
14	4 - 10	12 - 20			14
15	3 - 6	6 - 12			15
16					16
17					17
18					18
21	4 - 10	12 - 20			21
22	3 - 6	6 - 12			22
23	3 - 6	6 - 12			23
24	3 - 6	6 - 12			24
31					31
32					32
41					41
42					42
51	3 - 6	6 - 12			51
52					52
53					53
61	4 - 10	12 - 20			61
62	4 - 10	12 - 20			62
63	4 - 10	12 - 20			63
64	4 - 10	12 - 20			64
71	4 - 10	12 - 20			71
72	4 - 10	12 - 20			72
73	4 - 10	12 - 20			73
74					74
81					81
82					82
83					83
91	4 - 10	12 - 20			91
92	4 - 10	12 - 20			92
93	4 - 10	12 - 20			93
94	4 - 10	12 - 20			94



				FA		CFA	
Характеристики Characteristics							
Типы отверстий Hole type							
				FA80VS	FA83VS	CFA80VS	CFA83VS
M	4HX / 6HX	ISO DIN 14 ISO DIN 13	DC ~DIN 371	363	363	370	370
MF	4HX / 6HX	ISO DIN 13	DC ~DIN 371	364	364		
UNC	2BX	ASME B1.1	DC ~DIN 371	365	365	371	371
	3BX	ASME B1.1	DC ~DIN 371	365	365		
UNF	2BX	ASME B1.1	DC ~DIN 371	366	366	372	372
	3BX	ASME B1.1	DC ~DIN 371	366	366		
S	NIHS	NIHS 06 - 10	DC	367	367	373	373
SF	NIHS	NIHS 06-10 Fine Thread	DC	368	368		
SL	Safelock	SL 15 - 01	DC	369	369		

FA

FA80VS



FA83VS



FA80VS

FA83VS

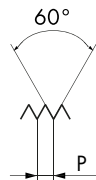
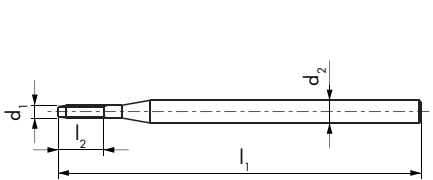

Ø d ₁ M	P mm	l ₁ mm	l ₂ mm	d ₂ mm		ID	ID
0.5	0.125	25	1.5	2	Δ0.44	● 161750	● 173719
0.6	0.15	25	1.8	2	Δ0.53	● 152412	● 173720
0.7	0.175	25	2.1	2	Δ0.62	● 152415	● 173721
0.8	0.2	25	2.4	2	Δ0.71	● 152418	● 173722
0.9	0.225	25	2.7	2	Δ0.8	● 152421	● 173723
1	0.25	40	3	2.5	Δ0.88	● 151559	● 173729
1.2	0.25	40	3.6	2.5	Δ1.08	● 151565	● 173730
1.4	0.3	40	4.2	2.5	Δ1.25	● 152429	● 173731

Δ Tol. = +0/0.02 mm

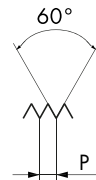
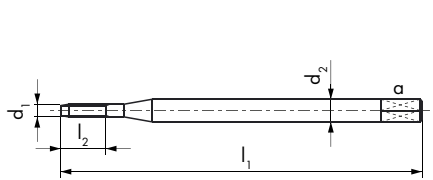

Ø d ₁ M	P mm	l ₁ mm	l ₂ mm	d ₂ mm	a mm		ID	ID
1.6	0.35	40	4.8	2.5		Δ1.45	● 152433	● 193801
1.8	0.35	40	5.4	2.5		Δ1.65	● 193764	● 193802
2	0.4	45	8	2.8	2.1	Δ1.8	● 151566	● 193803
2.3	0.4	45	9	2.8	2.1	Δ2.1	● 193765	● 193804
2.5	0.45	50	10	2.8	2.1	Δ2.3	● 193766	● 193805
2.6	0.45	50	10	2.8	2.1	Δ2.4	● 193767	● 193806

Δ Tol. = +0/0.02 mm

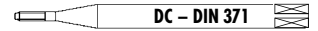

FA

FA80VS



VS

FA83VS



VS



FA80VS

FA83VS

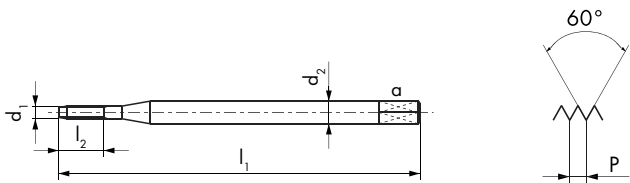

4HX

4HX

$\varnothing d_1$ MF	P mm	l_1 mm	l_2 mm	d_2 mm	a mm		ID	ID
1.4	0.2	40	4.2	2.5		$\Delta 1.31$	● 155928	● 180436
1.6	0.2	40	4.8	2.5		$\Delta 1.51$	● 156480	● 193807
1.8	0.2	40	5.4	2.5		$\Delta 1.71$	● 193768	● 193808
2	0.2	45	6	2.8	2.1	$\Delta 1.91$	● 193769	● 193809
2	0.25	45	6	2.8	2.1	$\Delta 1.88$	● 193770	● 193810
2.2	0.2	45	6.6	2.8	2.1	$\Delta 2.11$	● 193771	● 193811
2.2	0.25	45	6.6	2.8	2.1	$\Delta 2.08$	● 193772	● 193812
2.3	0.2	45	6.9	2.8	2.1	$\Delta 2.21$	● 193773	● 193813
2.3	0.25	45	6.9	2.8	2.1	$\Delta 2.18$	● 193774	● 193814
2.5	0.2	50	7.5	2.8	2.1	$\Delta 2.41$	● 193775	● 193815
2.5	0.25	50	7.5	2.8	2.1	$\Delta 2.38$	● 193776	● 193816

Δ Tol. = +0/0.02 mm

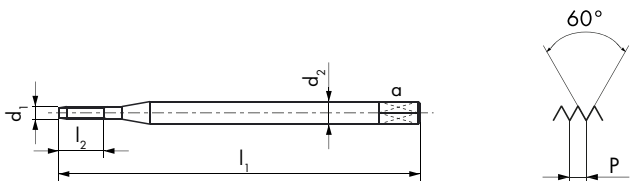

6HX

6HX

$\varnothing d_1$ MF	P mm	l_1 mm	l_2 mm	d_2 mm	a mm		ID	ID
2.5	0.35	50	7.5	2.8	2.1	$\Delta 2.35$	● 193777	● 193817
2.6	0.35	50	7.8	2.8	2.1	$\Delta 2.45$	● 193778	● 193818

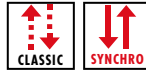

Δ Tol. = +0/0.02 mm



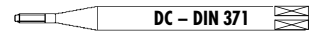

PM



FA

FA80VS  

FA83VS  

11	12	13	14	15
21	22	23	24	51
61	63	64	71	72
73	91	92	94	

FA80VS

FA83VS

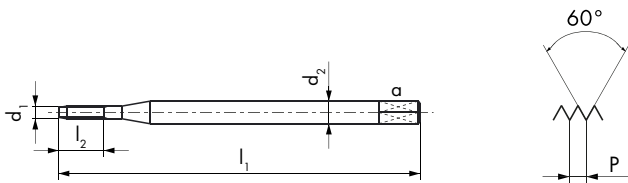

2BX

2BX

$\emptyset d_1$ UNC	P TPI	d_1 mm	l_1 mm	l_2 mm	d_2 mm	a mm	
1	64	1.85	40	5.6	2.5	2.1	$\Delta 1.65$
2	56	2.18	45	9	2.8	2.1	$\Delta 2$
3	48	2.51	50	10	2.8	2.1	$\Delta 2.25$

ID

ID

- | | |
|--|--|
| ● 193779 | ● 193819 |
| ● 193780 | ● 193820 |
| ● 193781 | ● 193821 |

Δ  Tol. = +0/0.02 mm

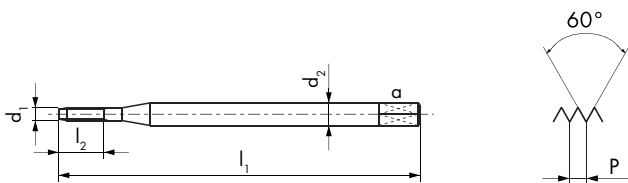

3BX

3BX

$\emptyset d_1$ UNC	P TPI	d_1 mm	l_1 mm	l_2 mm	d_2 mm	a mm	
1	64	1.85	40	5.6	2.5	2.1	$\Delta 1.65$
2	56	2.18	45	9	2.8	2.1	$\Delta 2$
3	48	2.51	50	10	2.8	2.1	$\Delta 2.25$

ID

ID

- | | |
|--|--|
| ● 193782 | ● 193822 |
| ● 193783 | ● 193823 |
| ● 193784 | ● 193824 |



Δ  Tol. = +0/0.02 mm



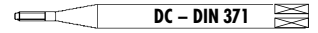

PM



FA

FA80VS  

FA83VS  

11	12	13	14	15
21	22	23	24	51
61	63	64	71	72
73	91	92	94	

FA80VS

FA83VS

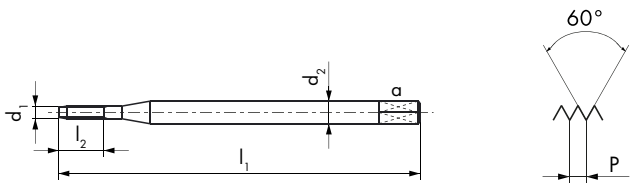

2BX

2BX

$\emptyset d_1$ UNF	P TPI	d_1 mm	l_1 mm	l_2 mm	d_2 mm	a mm	
0	80	1.52	40	4.6	2.5		$\Delta 1.4$
1	72	1.85	40	5.6	2.5		$\Delta 1.7$
2	64	2.18	45	9	2.8	2.1	$\Delta 2$
3	56	2.51	50	10	2.8	2.1	$\Delta 2.3$

Δ  Tol. = +0/0.02 mm

ID

ID

- | | |
|--|--|
| ● 193785 | ● 193825 |
| ● 193786 | ● 193826 |
| ● 193787 | ● 193827 |
| ● 193788 | ● 193828 |

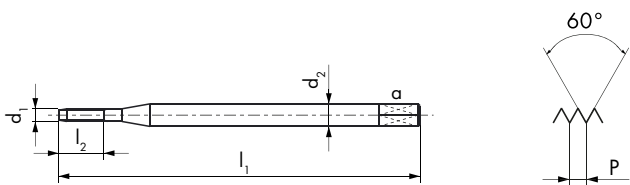

3BX

3BX

$\emptyset d_1$ UNF	P TPI	d_1 mm	l_1 mm	l_2 mm	d_2 mm	a mm	
0	80	1.52	40	4.6	2.5		$\Delta 1.4$
1	72	1.85	40	5.6	2.5		$\Delta 1.7$
2	64	2.18	45	9	2.8	2.1	$\Delta 2$
3	56	2.51	50	10	2.8	2.1	$\Delta 2.3$

Δ  Tol. = +0/0.02 mm

ID

ID

- | | |
|--|--|
| ● 193789 | ● 193829 |
| ● 193790 | ● 193830 |
| ● 193791 | ● 193831 |
| ● 193792 | ● 193832 |



FA

FA80VS



FA83VS



FA80VS

FA83VS

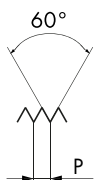
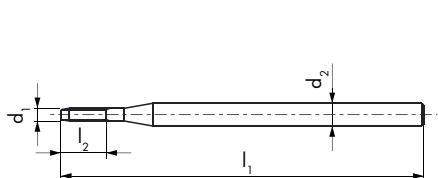

$\varnothing d_1$ S	P mm	l_1 mm	l_2 mm	d_2 mm	
0.5	0.125	25	1.5	2	$\Delta 0.44$
0.6	0.15	25	1.8	2	$\Delta 0.53$
0.7	0.175	25	2.1	2	$\Delta 0.62$
0.8	0.2	25	2.4	2	$\Delta 0.71$
0.9	0.225	25	2.7	2	$\Delta 0.8$
1	0.25	40	3.0	2.5	$\Delta 0.88$
1.2	0.25	40	3.6	2.5	$\Delta 1.08$
1.4	0.3	40	4.2	2.5	$\Delta 1.25$

ID

ID

● 158977	● 173724
● 151561	● 173725
● 151742	● 173726
● 151564	● 173727
● 151562	● 173728
● 151542	● 173732
● 151543	● 173733
● 152427	● 173734

Δ Tol. = +0/0.02 mm

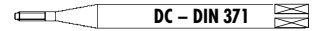

FA

FA80VS



FA83VS



FA80VS

FA83VS

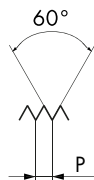
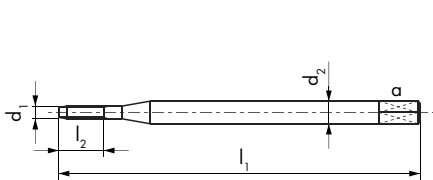

$\emptyset d_1$ SF	P mm	l_1 mm	l_2 mm	d_2 mm	a mm	
1.4	0.2	40	4.2	2.5		$\Delta 1.31$
1.6	0.2	40	4.8	2.5		$\Delta 1.51$
1.8	0.2	40	5.4	2.5		$\Delta 1.71$
2	0.2	45	6	2.8	2.1	$\Delta 1.91$
2.2	0.2	45	6.6	2.8	2.1	$\Delta 2.11$
2.2	0.25	45	6.6	2.8	2.1	$\Delta 2.08$
2.5	0.2	50	7.5	2.8	2.1	$\Delta 2.41$
2.5	0.25	50	7.5	2.8	2.1	$\Delta 2.38$

ID	ID
● 176180	● 193793
● 193757	● 193794
● 193758	● 193795
● 193759	● 193796
● 193760	● 193797
● 193761	● 193798
● 193762	● 193799
● 193763	● 193800

Δ Tol. = +0/0.02 mm

FA

FA80VS



FA83VS



FA80VS

FA83VS

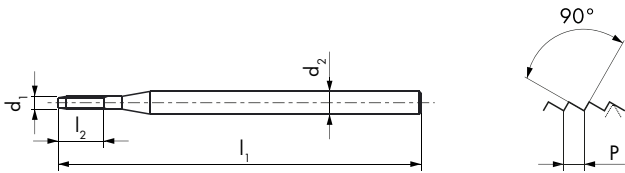

$\emptyset d_1$ SL	P mm	l_1 mm	l_2 mm	d_2 mm	ID	ID
0.5	0.1	25	1.5	2	● 600049	● 600100
0.6	0.125	25	1.8	2	● 600050	● 600101
0.7	0.15	25	2.1	2	● 600051	● 600102
0.8	0.15	25	2.4	2	● 600052	● 600103
0.9	0.175	25	2.7	2	● 600053	● 600104
1	0.2	40	3	2.5	● 600054	● 600105
1.2	0.2	40	3.6	2.5	● 600055	● 600106
1.4	0.25	40	4.2	2.5	● 600056	● 600107

CFA

CFA80VS



CFA83VS



62 63 91 92 94

CFA80VS

CFA83VS



4HX

4HX

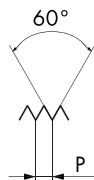
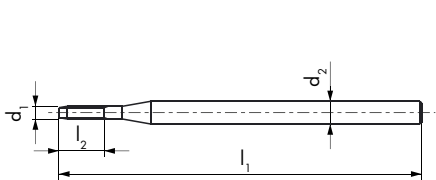

$\emptyset d_1$ M	P mm	l_1 mm	l_2 mm	d_2 h5 mm	
0.5	0.125	32	1.5	1.5	$\Delta 0.44$
0.6	0.15	32	1.8	1.5	$\Delta 0.53$
0.7	0.175	32	2.1	1.5	$\Delta 0.62$
0.8	0.2	32	2.4	1.5	$\Delta 0.71$
0.9	0.225	32	2.7	1.5	$\Delta 0.8$
1	0.25	32	3	2	$\Delta 0.88$
1.2	0.25	32	3.6	2	$\Delta 1.08$
1.4	0.3	32	4.2	2	$\Delta 1.25$

Δ Tol. = +0/0.02 mm

ID

ID

● 171771	● 193611
● 171773	● 193612
● 171775	● 193613
● 171777	● 193614
● 171779	● 193615
● 171782	● 193616
● 171783	● 193617
● 171785	● 193618

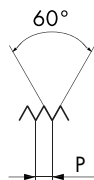
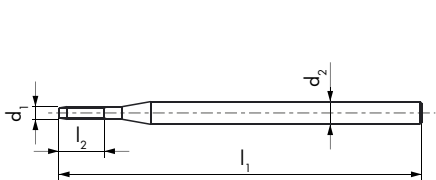

$\emptyset d_1$ M	P mm	l_1 mm	l_2 mm	d_2 h5 mm	
1.6	0.35	32	4.8	2	$\Delta 1.45$
1.8	0.35	32	5.4	2	$\Delta 1.65$
2	0.4	39	8	3	$\Delta 1.8$
2.3	0.4	39	9	3	$\Delta 2.1$
2.5	0.45	39	10	3	$\Delta 2.3$
2.6	0.45	39	10	3	$\Delta 2.4$

Δ Tol. = +0/0.02 mm

6HX

6HX

ID

ID

● 193590	● 193619
● 193591	● 193620
● 193592	● 193621
● 193593	● 193622
● 193594	● 193623
● 193595	● 193624



CFA

CFA80VS



62 63 91 92 94

CFA83VS



CFA80VS

CFA83VS

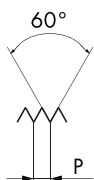
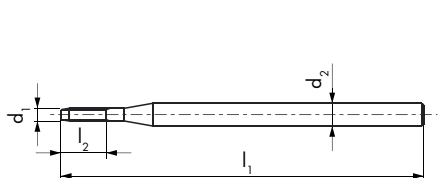

$\emptyset d$ UNC	P TPI	d_1 mm	l_1 mm	l_2 mm	d_2 h5 mm	
1	64	1.85	32	5.5	2	$\Delta 1.65$
2	56	2.18	39	8.6	3	$\Delta 2$
3	48	2.51	39	10	3	$\Delta 2.25$

ID

ID

● 193596	● 193625
● 193597	● 193626
● 193598	● 193627

Δ Tol. = +0/0.02 mm



CFA

CFA80VS



62 63 91 92 94

CFA83VS



CFA80VS

CFA83VS



2BX

2BX

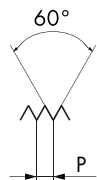
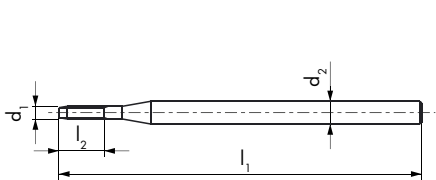

$\emptyset d$ UNF	P TPI	d_1 mm	l_1 mm	l_2 mm	d_2 ^{h5} mm	
0	80	1.52	32	4.5	2	$\Delta 1.4$
1	72	1.85	32	5.5	2	$\Delta 1.7$
2	64	2.18	39	8.6	3	$\Delta 2$
3	56	2.51	39	10	3	$\Delta 2.3$

ID

ID

● 193599	● 193628
● 193600	● 193629
● 193601	● 193630
● 193602	● 193631

Δ Tol. = +0/0.02 mm



CFA

CFA80VS

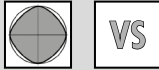

62 63 91 92 94

CFA83VS



CFA80VS

CFA83VS

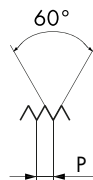
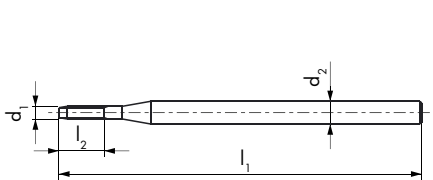

$\emptyset d_1$ S	P mm	l_1 mm	l_2 mm	d_2 h5 mm	
0.5	0.125	32	1.5	1.5	$\Delta 0.44$
0.6	0.15	32	1.8	1.5	$\Delta 0.53$
0.7	0.175	32	2.1	1.5	$\Delta 0.62$
0.8	0.2	32	2.4	1.5	$\Delta 0.71$
0.9	0.225	32	2.7	1.5	$\Delta 0.8$
1	0.25	32	3	2	$\Delta 0.88$
1.2	0.25	32	3.6	2	$\Delta 1.08$
1.4	0.3	32	4.2	2	$\Delta 1.25$

ID

ID

● 171770	● 193603
● 171772	● 193604
● 171774	● 193605
● 171776	● 193606
● 171778	● 193607
● 171780	● 193608
● 171781	● 193609
● 171784	● 193610

Δ Tol. = +0/0.02 mm

РЕЗЬБОВЫЕ КАЛИБРЫ НАНО — NANO THREAD GAUGES

НАНО РЕЗЬБОВЫЕ КАЛИБРЫ — THREAD PLUG GAUGES



МЕТРОЛОГИЯ — METROLOGY



ПРОИЗВОДСТВО — PRODUCTION



< 2.74 mm

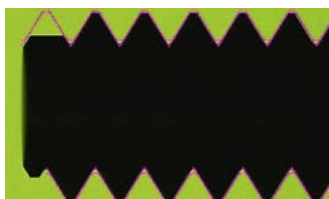

ИСПОЛЬЗОВАНИЕ

Тот факт, что начальный поворот винтовой резьбы, а также наконечник калибра отшлифованы абсолютно плоско, гарантирует, что инструмент оптимально входит в резьбу, что имеет важное значение для обеспечения правильного измерения. Это позволяет калибру проверить резьбу на ее максимальной глубине.

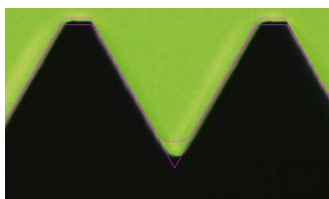

УПРАВЛЕНИЕ ПРОФИЛЕМ

Наш опыт в области процесса исключения погрешностей гарантирует, что у нас есть идеальный контроль допусков для формы профиля и текстуры поверхности.

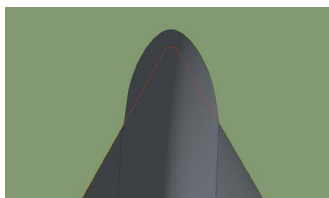

КАЛИБРЫ-КОЛЬЦА "НЕ"

Вырез на наружном диаметре наших кольцевых датчиков НЕ обеспечивает оптимальную проверку боковых поверхностей винта, устраняя риск любого неправильного контроля, вызванного засорением наружного диаметра калибра.



МОДУЛЬНАЯ СИСТЕМА

Соединительный винт позволяет соединять калибр ПР с секцией НЕ по мере необходимости. Жесткая коробочка защищает калибры во время транспортировки. Его формованная внутренняя поверхность сохраняет продукт чистым и защищает его от ударов.

РЕЗЬБОВЫЕ КАЛИБРЫ-ПРОБКИ — PLUG CHECK GAUGES

Контр-калибр пробка "НЕ" простое устройство для контроля новых колец.

The **NO-GO** plug check gauge is the foolproofing device for the new ring gauge.

Контр-калибр пробка "ПР" для контроля качества колец.

The **GO** plug check gauge is used to check the quality of your ring gauge.



Контр-калибр Износа продлит срок службы вашего кольца датчика до определенного предел допуска.

The master plug gauge **WEAR** will extend the service life of your ring gauge up to a certain tolerance limit.

UTILISATION

The fact that the initial turn of the screw thread and also the tip of the gauge have been ground flat ensures that the tool engages optimally in the thread, which is essential for ensuring a correct measurement. This enables the gauge to check the thread at its maximum depth.

PROFILE CONTROL

Our expertise in the field of rectification ensures we have perfect control of tolerances for the shape of the profile and for surface textures.

NO-GO RING GAUGE

The cut-away on the exterior diameter of our NO-GO ring gauges ensures the sides of the screw can be optimally checked, eliminating the risk of any incorrect inspection caused by a blockage on the exterior diameter of the gauge.

MODULAR SYSTEM

A coupling screw enables the GO gauge to be connected to the NO-GO section as required. The rigid box protects the gauges during transportation. Its moulded interior keeps the product clean and protects it from impacts.

СЕРТИФИКАТ ИЗМЕРЕНИЯ SCS



Сертификат-это письменное подтверждение качества метрологического оборудования предприятия. DC NANO TOOLS SA (аккредитация SCS 0143), член группы DC SWISS, может проверить и откалибровать резьбовые калибры для вас в соответствии с международным стандартом ISO 17025. Эта платная услуга доступна для диаметров шага от 0.1 до 3.0 мм и наружных диаметров от 0.1 до 3.5 мм.

Все резьбовые калтбры-пробки сертифицированы SCS.

© DC NANO TOOLS SA аккредитован по ISO 17025:2017

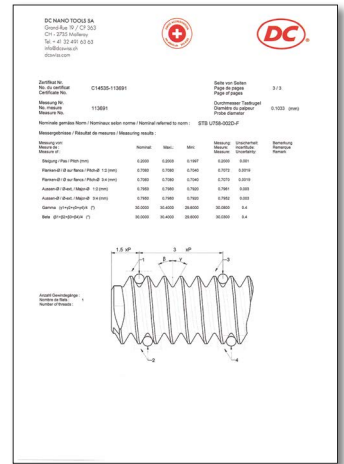

SCS MEASUREMENT CERTIFICATE



A certificate is written confirmation of the quality of a company's metrological equipment. DC NANO TOOLS SA (SCS accreditation 0143), a member of the DC SWISS Group, can inspect and calibrate thread gauges for you in accordance with the ISO 17025 international standard. This chargeable service is available for pitch diameters of 0.1 to 3.0 mm and external diameters of 0.1 to 3.5 mm.

All plug thread gauges are SCS certified.

ISO 17025:2017 accredited © DC NANO TOOLS SA

ЗАГРУЗИТЕ СВОЕ ПОДТВЕРЖДЕНИЕ СООТВЕТСТВИЯ ТРЕБОВАНИЯМ

Теперь вы можете получить доступ к своему подтверждению соответствия требованиям в любое время, в любом месте на вашем телефоне. Просто отсканируйте QR-код на карточке внутри коробки и загрузите соответствующий pdf-файл.

Подтверждение соответствия, сопровождающее каждую коробку, подтверждает, что завод scrupulously следил за процессом пост-производственного мониторинга.

DC SWISS SA контроль качества

DOWNLOAD YOUR CONFIRMATION OF COMPLIANCE

You can now access your confirmation of compliance any time, at any place on your phone. Simply scan the QR code on the card inside the box and download the associated pdf file.

The confirmation of compliance accompanying each box confirms that the factory has scrupulously followed the post-production monitoring process.

DC SWISS SA quality control

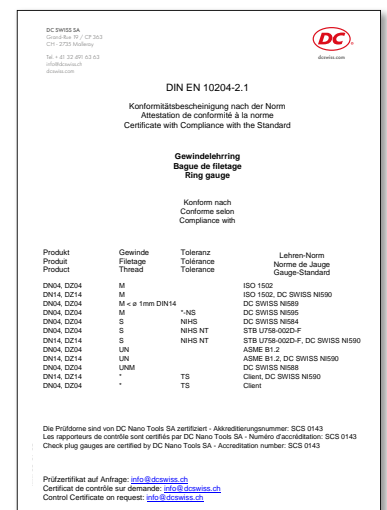

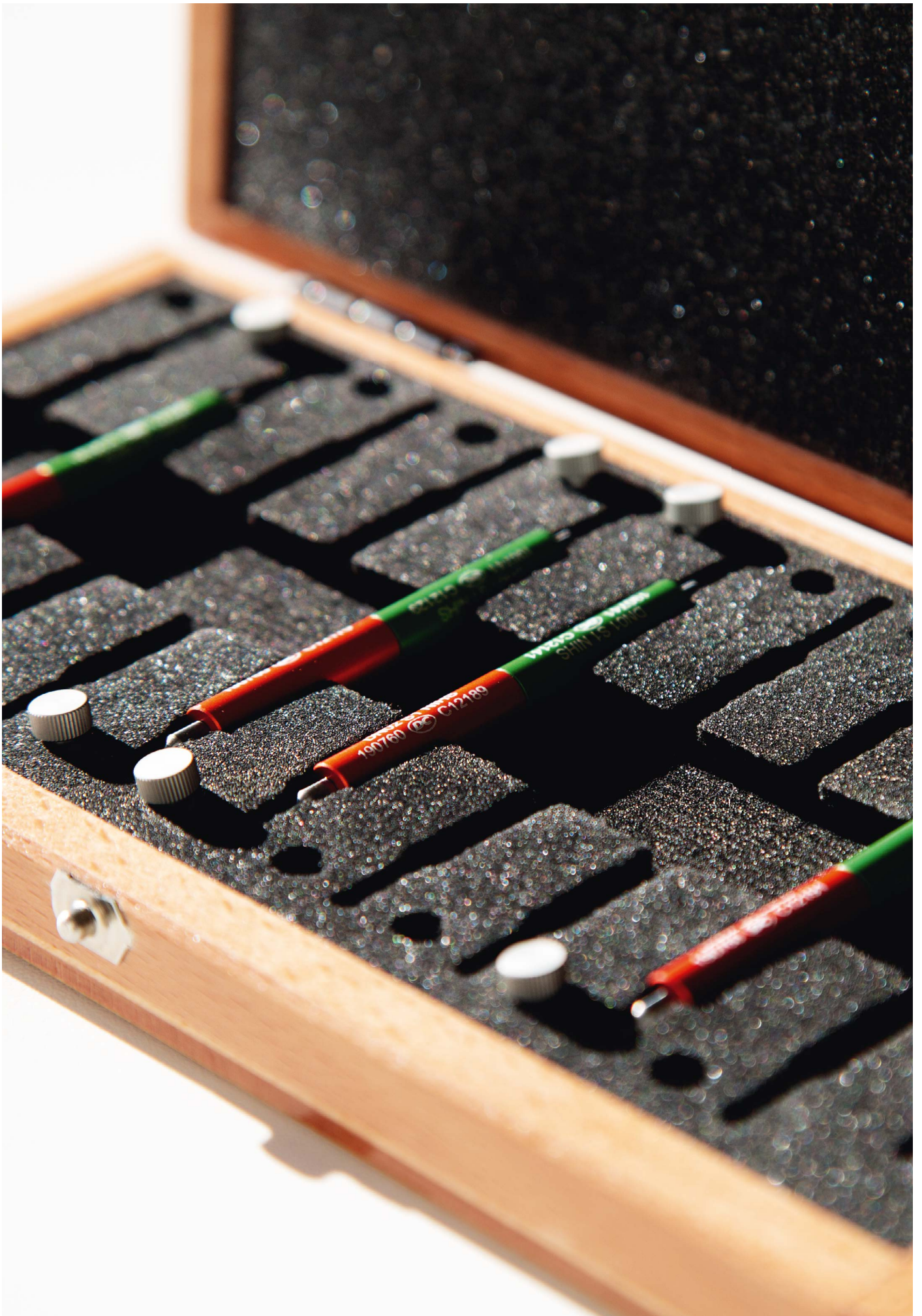

СУЩЕСТВУЮЩИЕ НАБОРЫ — AVAILABLE SETS



**РЕЗЬБОВЫЕ КАЛИБРЫ ПРОБКИ И КОЛЬЦА DN
THREAD PLUG GAUGES & RING GAUGES DN**

ЕДИНИЧНЫЙ НАБОР — SINGLE SET



**РЕЗЬБОВЫЕ КАЛИБРЫ КОЛЬЦА DZ
THREAD RING GAUGES DZ**

ЕДИНИЧНЫЙ НАБОР — SINGLE SET



**РЕЗЬБОВЫЕ КАЛИБРЫ ПРОБКИ DN /
РЕЗЬБОВЫЕ КАЛИБРЫ КОЛЬЦА DN
PLUG GAUGES DN / RING GAUGES DN**

**НАБОР ИЗ 10 ИЛИ 20 ШТ
SET OF 10 OR 20 ITEMS**

Вы можете выбрать точное количество
ПР / НЕ калибров в каждом наборе.

Свяжитесь с нами по вопросам содержания наборов.

You can select the exact number of
GO / NO-GO thread gauges for each set.

Contact us for any other set compositions.

dcswiss.com / info@dcswiss.ch / +41 32 491 63 63

ЗАКАЗ НА РЕЗЬБОВЫЕ КАЛИБРЫ НАНО — NANO THREAD GAUGES ORDER

ТИП ИНСТРУМЕНТА — TOOL TYPE

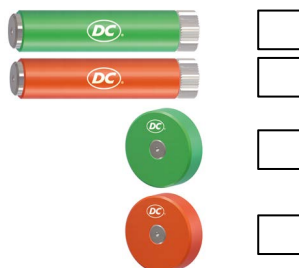

ХАРАКТЕРИСТИКИ — CHARACTERISTICS

РАЗМЕРЫ DIMENSION	ДОПУСК TOLERANCE	СТАНДАРТ NORM	КОЛИЧЕСТВО QUANTITY	ОСОБЕННОСТИ SPECIFICS

ПРИМЕЧАНИЯ — REMARKS

ИНФОРМАЦИЯ О ДОСТАВКЕ — DELIVERY INFORMATION



Спасибо за запрос.
Thank you for initiating your order.



Указатель — Резьбовые калибры НАНО для микромеханики и часовой промышленности
Directory — Thread gauges NANO for micromechanics and watchmaking

	Резьбовые калибры-пробки Thread plug gauges			Резьбовые калибры-кольца Thread ring gauges				Контр-калибры Plug check gauges			
Характеристики Characteristics											
Тип Type											
	DN01 GO	DN01 GO	DN02 NO-GO	DZ04 GO	DZ14 NO-GO	DN04 GO	DN14 NO-GO	RN05-1 GO	RN15-1 GO	RN05-2 NO-GO	RN15-2 NO-GO
M 4H / 5h ISO DIN 14 ISO DIN 13		382	382	383	383	384	384	399	399	400	400
M 6H / 6g ISO DIN 13		382	382	383	383	384	384	399	399	400	400
M 5H / 6h ISO DIN 13		382	382	383	383	384	384	399	399	400	400
MF 4H / 4h ISO DIN 13		385	385	386	386	387	387	402	402	403	403
MF 6H / 6g ISO DIN 13		385	385	386	386	387	387	402	402	403	403
MF 6h ISO DIN 13				386	386	387	387	402	402	403	403
UNC 2B / 2A ASME B1.1		388	388	389	389	390	390	405	405	406	406
UNC 3B / 3A ASME B1.1		388	388	389	389	390	390	405	405	406	406
UNF 2B / 2A ASME B1.1		388	388	389	389	390	390	405	405	406	406
UNF 3B / 3A ASME B1.1		388	388	389	389	390	390	405	405	406	406
S NIHS 3G NIHS	391										
S NIHS 4H NIHS		391									
S NIHS 4H / 3G NIHS			391								
S NIHS NIHS				393	393	394	394	407	407	408	408
S NIHS NT NIHS		392	392	393	393	394	394	407	407	408	408
SF NIHS 3G NIHS	395										
SF NIHS 4H NIHS		395									
SF NIHS 4H / 3G NIHS			395								
SF NIHS NIHS				396	396	397	397	409	409	410	410
SF NIHS NT NIHS								409	409	410	410
SL SL 15-01		398	398								

Указатель — Резьбовые калибры НАНО для микромеханики и часовой промышленности
Directory — Thread gauges NANO for micromechanics and watchmaking

	Контр-калибры контроля износа Master plug gauges WEAR		Калибровочные калибры пробки Calibration thread plug gauges
Характеристики Characteristics			
			
Тип Type	RN05-3 WEAR	RN15-3 WEAR	EN00
M 4H / 5h	ISO DIN 14 ISO DIN 13		
M 6H / 6g	ISO DIN 14 ISO DIN 13	401	401
M 5H / 6h	ISO DIN 13	401	401
MF 4H / 4h	ISO DIN 13	404	404
MF 6H / 6g	ISO DIN 13	404	404
MF 6h	ISO DIN 13	404	404
S NIHS	NIHS		411

Пиктограммы - Pictographs



"ПР"
"Go"



"НЕ"
"No-Go"



Допуск 6H, "ПР"
Tolerance 6H, "Go"



Допуск 6g, "НЕ"
Tolerance 6g, "No-Go"

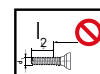

Макс. длина измерения l2
не должна превышать
Max. measuring length l2
must not be exceeded



Финол КЛ
Phynox KL



Все резьбовые калибры по запросу
могут быть поставлены для левых резьб
All gauges can be supplied with
a left-hand thread upon request

Использовать — Use

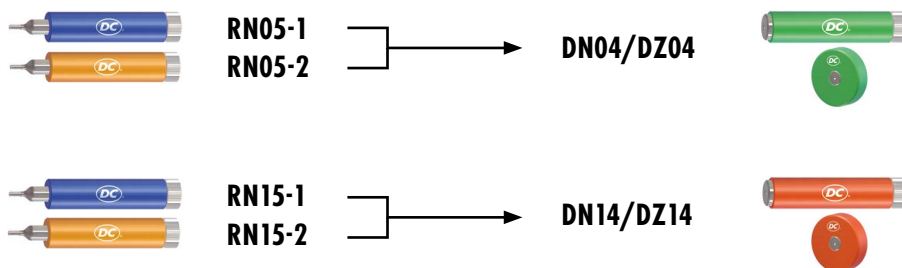

nano

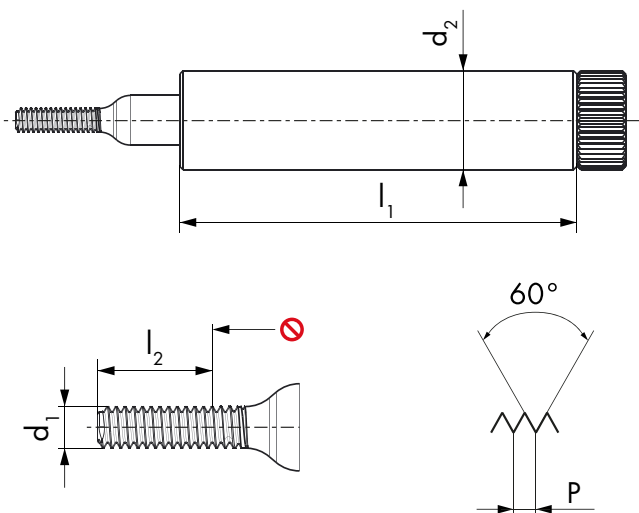

DN01 GO DN02 NO-GO DN01 GO DN02 NO-GO



4H 4H 5H 5H

$\emptyset d_1$ M	P mm	l_1 mm	l_2 GO mm	d_2 mm	ID	ID	ID	ID
0.3	0.08	24	0.9	6	● 192778	● 192786		
0.35	0.09	24	1.05	6	● 192779	● 192787		
0.4	0.1	24	1.2	6	● 192780	● 192788		
0.5	0.125	24	1.5	6	● 192781	● 192789		
0.6	0.15	24	1.8	6	● 192782	● 192790		
0.7	0.175	24	2.1	6	● 192783	● 192791		
0.8	0.2	24	2.4	6	● 192784	● 192792		
0.9	0.225	24	2.7	6	● 192785	● 192793		
1	0.25	24	3	6	● 191113	● 191127	● 191421	● 191424
1.2	0.25	24	3.6	6	● 191114	● 191128	● 191422	● 191425
1.4	0.3	24	4.2	6	● 191115	● 191129	● 191423	● 191426

6H 6H

$\emptyset d_1$ M	P mm	l_1 mm	l_2 GO mm	d_2 mm	ID	ID
1.6	0.35	24	4.5	6	● 191427	● 191433
1.8	0.35	24	4.5	6	● 191428	● 191434
2	0.4	24	4.5	6	● 191429	● 191435
2.3	0.4	24	4.5	6	● 191430	● 191436
2.5	0.45	24	4.5	6	● 191431	● 191437
2.6	0.45	24	4.5	6	● 191432	● 191438



All nano thread plug gauges are SCS-certified and the paid certificate is available on request.



nano

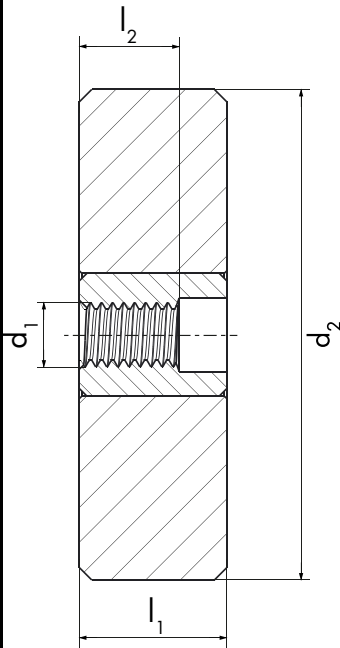

DZ04 GO	DZ14 NO-GO	DZ04 GO	DZ14 NO-GO
---------	------------	---------	------------



5h	5h	6h	6h
-----------	-----------	-----------	-----------

$\emptyset d_1$ M	P mm	l_1 mm	l_2 GO mm	d_2 mm	ID	ID	ID	ID
* 0.3	0.08	6	0.45	20	● 192842	● 192850		
* 0.35	0.09	6	0.53	20	● 192843	● 192851		
0.4	0.1	6	0.6	20	● 192844	● 192852		
0.5	0.125	6	0.75	20	● 192845	● 192853		
0.6	0.15	6	0.9	20	● 192846	● 192854		
0.7	0.175	6	1.05	20	● 192847	● 192855		
0.8	0.2	6	1.2	20	● 192848	● 192856		
0.9	0.225	6	1.35	20	● 192849	● 192857		
1	0.25	6	1.5	20			● 191473	● 191476
1.2	0.25	6	1.8	20			● 191474	● 191477
1.4	0.3	6	2.1	20			● 191475	● 191478
* In development								

6g	6g
-----------	-----------

$\emptyset d_1$ M	P mm	l_1 mm	l_2 GO mm	d_2 mm	ID	ID
1.6	0.35	6	2.4	20	● 191479	● 191485
1.8	0.35	6	2.7	20	● 191480	● 191486
2	0.4	6	3	20	● 191481	● 191487
2.3	0.4	6	3.45	20	● 191482	● 191488
2.5	0.45	6	3.75	20	● 191483	● 191489
2.6	0.45	6	3.9	20	● 191484	● 191490



All nano ring gauges have a certificate of measurement, established with SCS certified plug check gauges. The paid certificate is available on request.



nano

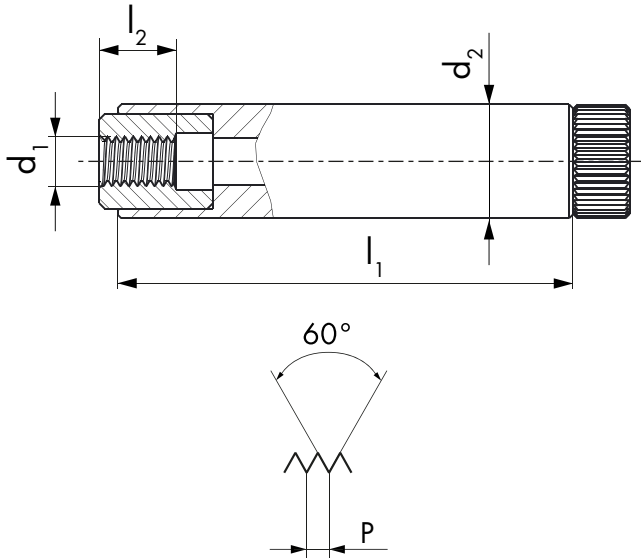

DN04 GO DN14 NO-GO DN04 GO DN14 NO-GO



$\emptyset d_1$ M	P mm	l_1 mm	l_2 GO mm	d_2 mm	ID	ID	ID	ID
* 0.3	0.08	24	0.45	6	● 192800	● 192808		
* 0.35	0.09	24	0.53	6	● 192801	● 192809		
0.4	0.1	24	0.6	6	● 192802	● 192810		
0.5	0.125	24	0.75	6	● 192803	● 192811		
0.6	0.15	24	0.9	6	● 192804	● 192812		
0.7	0.175	24	1.05	6	● 192805	● 192813		
0.8	0.2	24	1.2	6	● 192806	● 192814		
0.9	0.225	24	1.35	6	● 192807	● 192815		
1	0.25	24	1.5	6			● 191447	● 191450
1.2	0.25	24	1.8	6			● 191448	● 191451
1.4	0.3	24	2.1	6			● 191449	● 191452
* In development								



$\emptyset d_1$ M	P mm	l_1 mm	l_2 GO mm	d_2 mm	ID	ID
1.6	0.35	24	2.4	6	● 191453	● 191459
1.8	0.35	24	2.7	6	● 191454	● 191460
2	0.4	24	3	6	● 191455	● 191461
2.3	0.4	24	3.45	6	● 191456	● 191462
2.5	0.45	24	3.75	6	● 191457	● 191463
2.6	0.45	24	3.9	6	● 191458	● 191464



All nano ring gauges have a certificate of measurement, established with SCS certified plug check gauges. The paid certificate is available on request.

nano

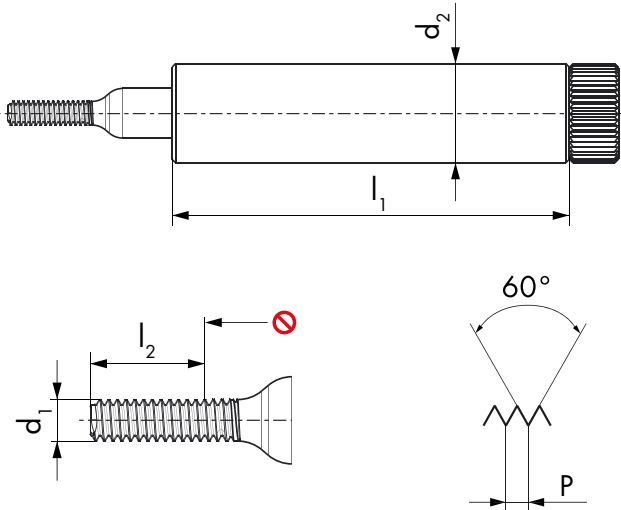

DN01 GO

DN02 NO-GO

DN01 GO

DN02 NO-GO



4H

4H

6H

6H

$\emptyset d_1$ MF	P mm	l_1 mm	l_2 GO mm	d_2 mm	ID	ID	ID	ID
1.4	0.2	24	4.2	6	● 191116	● 191130		
1.6	0.2	24	3	6	● 191117	● 191131		
1.8	0.2	24	3	6	● 191118	● 191132		
2	0.2	24	3	6	● 191119	● 191133		
2	0.25	24	3	6	● 192794	● 192797		
2.2	0.2	24	3	6	● 191120	● 191134		
2.2	0.25	24	3	6	● 191121	● 191135		
2.3	0.2	24	3	6	● 191122	● 191136		
2.3	0.25	24	3	6	● 191123	● 191137		
2.5	0.2	24	3	6	● 191124	● 191138		
2.5	0.25	24	3	6	● 191125	● 191139		
2.5	0.35	24	4.5	6			● 192795	● 192798
2.6	0.35	24	4.5	6			● 192796	● 192799



All nano thread plug gauges are SCS-certified and the paid certificate is available on request.

nano

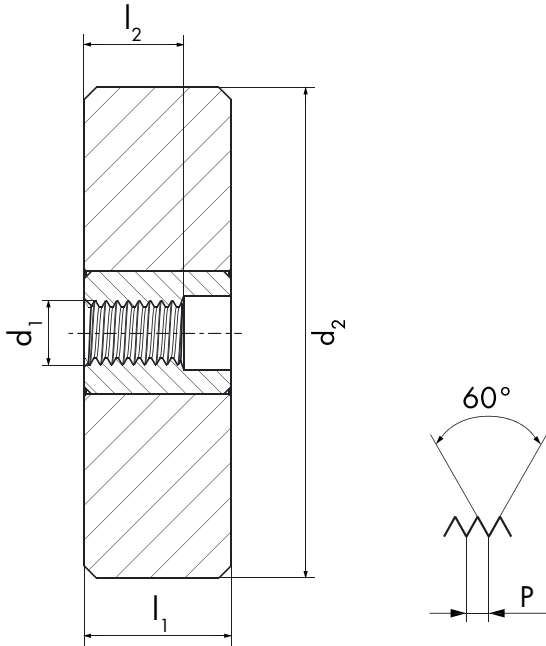

DZ04 GO

DZ14 NO-GO

DZ04 GO

DZ14 NO-GO



4h

4h

6g

6g

$\emptyset d_1$ MF	P mm	l_1 mm	l_2 GO mm	d_2 mm	ID	ID	ID	ID
1.4	0.2	6	2.1	20	● 194887	● 194888	● 192858 ¹	● 192871 ¹
1.6	0.2	6	1.8	20	● 191201	● 191215	● 191229	● 191243
1.8	0.2	6	1.8	20	● 191202	● 191216	● 191230	● 191244
2	0.2	6	1.8	20	● 190711	● 190710	● 191231	● 191245
2	0.25	6	2.25	20	● 194872	● 190690	● 194876	● 194877
2.2	0.2	6	1.8	20	● 191204	● 191218	● 191232	● 191246
2.2	0.25	6	2.25	20	● 191205	● 191219	● 191233	● 191247
2.3	0.2	6	1.8	20	● 191206	● 191220	● 191234	● 191248
2.3	0.25	6	2.25	20	● 191207	● 191221	● 191235	● 191249
2.5	0.2	6	1.8	20	● 191208	● 191222	● 191236	● 191250
2.5	0.25	6	2.25	20	● 194873	● 191223	● 191237	● 191251
2.5	0.35	6	3.75	20			● 192869	● 192882
2.6	0.35	6	3.9	20			● 192870	● 192883

¹ Tol. 6h



All nano ring gauges have a certificate of measurement, established with SCS certified plug check gauges. The paid certificate is available on request.

nano

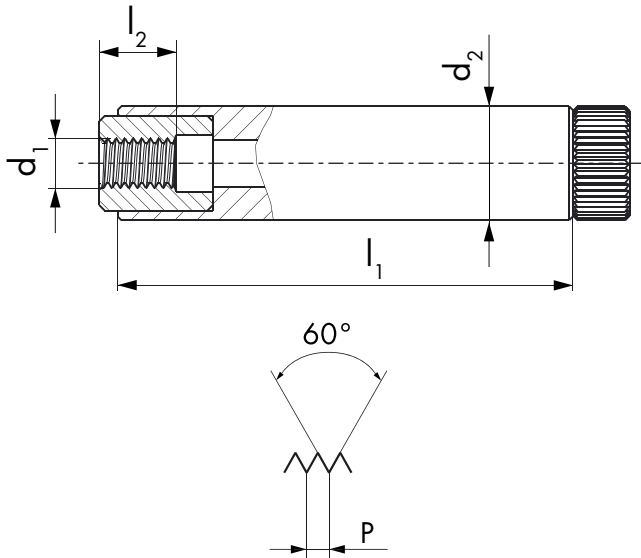

DN04 GO

DN14 NO-GO

DN04 GO

DN14 NO-GO



$\emptyset d_1$ MF	P mm	l_1 mm	l_2 GO mm	d_2 mm	ID	ID	ID	ID
1.4	0.2	24	2.1	6	● 194885	● 194886	● 192816 ¹	● 192829 ¹
1.6	0.2	24	1.8	6	● 191145	● 191159	● 191173	● 191187
1.8	0.2	24	1.8	6	● 191146	● 191160	● 191174	● 191188
2	0.2	24	1.8	6	● 191147	● 191161	● 191175	● 191189
2	0.25	24	2.25	6	● 194870	● 194871	● 194874	● 194875
2.2	0.2	24	1.8	6	● 191148	● 191162	● 191176	● 191190
2.2	0.25	24	2.25	6	● 191149	● 191163	● 191177	● 191191
2.3	0.2	24	1.8	6	● 191150	● 191164	● 191178	● 191192
2.3	0.25	24	2.25	6	● 191151	● 191165	● 191179	● 191193
2.5	0.2	24	1.8	6	● 191152	● 191166	● 191180	● 191194
2.5	0.25	24	2.25	6	● 191153	● 191167	● 191181	● 191195
2.5	0.35	24	3.75	6			● 192827	● 192840
2.6	0.35	24	3.9	6			● 192828	● 192841

¹ Tol. 6h



All nano ring gauges have a certificate of measurement, established with SCS certified plug check gauges. The paid certificate is available on request.

UNC, UNF ASME B1.1 ASME B1.2

VHM
CAR

nano

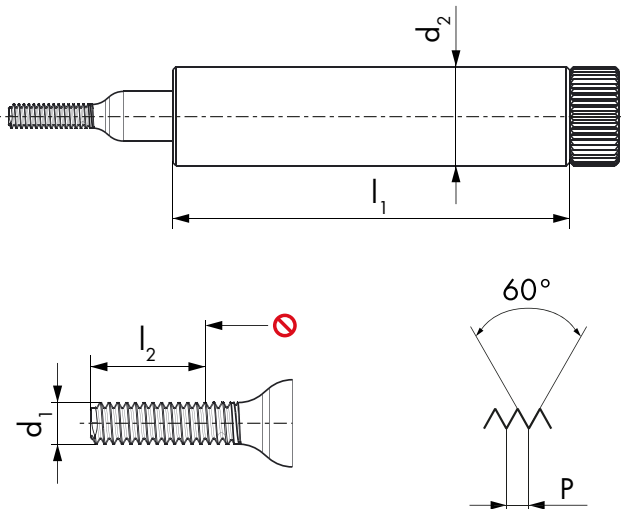

DN01 GO

DN02 NO-GO

DN01 GO

DN02 NO-GO



2B

2B

3B

3B

$\emptyset d_1$ UNC	P TPI	$\emptyset d_1$ mm	l_1 mm	l_2 GO mm	d_2 mm	ID	ID	ID	ID
1	64	1.854	24	6.35	6	● 191577	● 191580	● 191583	● 191586
2	54	2.184	24	6.35	6	● 191578	● 191581	● 191584	● 191587
3	48	2.515	24	6.35	6	● 191579	● 191582	● 191585	● 191588
$\emptyset d_1$ UNF	P TPI	$\emptyset d_1$ mm	l_1 mm	l_2 GO mm	d_2 mm	ID	ID	ID	ID
0	80	1.524	24	4.76	6	● 191637	● 191641	● 191645	● 191649
1	72	1.854	24	4.76	6	● 191638	● 191642	● 191646	● 191650
2	64	2.184	24	4.76	6	● 191639	● 191643	● 191647	● 191651
3	56	2.515	24	4.76	6	● 191640	● 191644	● 191648	● 191652



All nano thread plug gauges are SCS-certified and the paid certificate is available on request.

UNC, UNF

ASME B1.1

DZ04: ASME B1.2 / DZ14: ASME B1.2, DC SWISS NI590

PHYN.
KL

nano

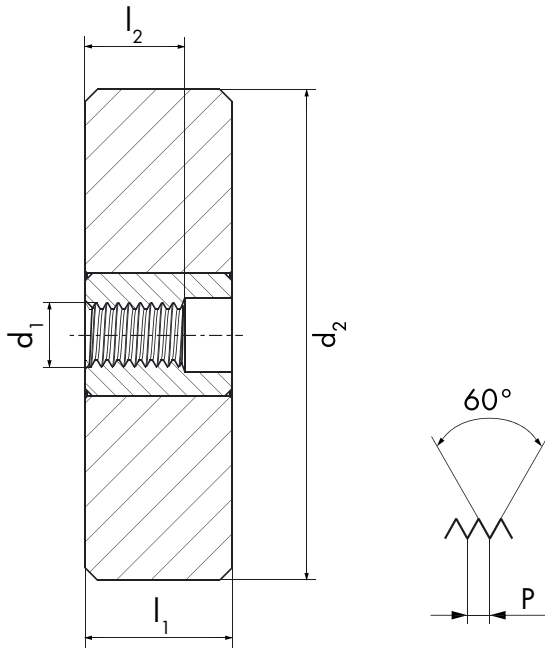

DZ04 GO

DZ14 NO-GO

DZ04 GO

DZ14 NO-GO



2A

2A

3A

3A

$\emptyset d_1$ UNC	P TPI	$\emptyset d_1$ mm	l_1 mm	l_2 GO mm	d_2 mm	ID	ID	ID	ID
1	64	1.854	6	2.78	20	● 191601	● 191604	● 191607	● 191610
2	56	2.184	6	3.28	20	● 191602	● 191605	● 191608	● 191611
3	48	2.515	6	3.77	20	● 191603	● 191606	● 191609	● 191612
$\emptyset d_1$ UNF	P TPI	$\emptyset d_1$ mm	l_1 mm	l_2 GO mm	d_2 mm	ID	ID	ID	ID
0	80	1.524	6	2.29	20	● 191669	● 191673	● 191677	● 191681
1	72	1.854	6	2.78	20	● 191670	● 191674	● 191678	● 191682
2	64	2.184	6	3.28	20	● 191671	● 191675	● 191679	● 191683
3	56	2.515	6	3.77	20	● 191672	● 191676	● 191680	● 191684



All nano ring gauges have a certificate of measurement, established with SCS certified plug check gauges. The paid certificate is available on request.

UNC, UNF

ASME B1.1

DN04: ASME B1.2 / DN14: ASME B1.2, DC SWISS NI590

PHYN.
KL

nano

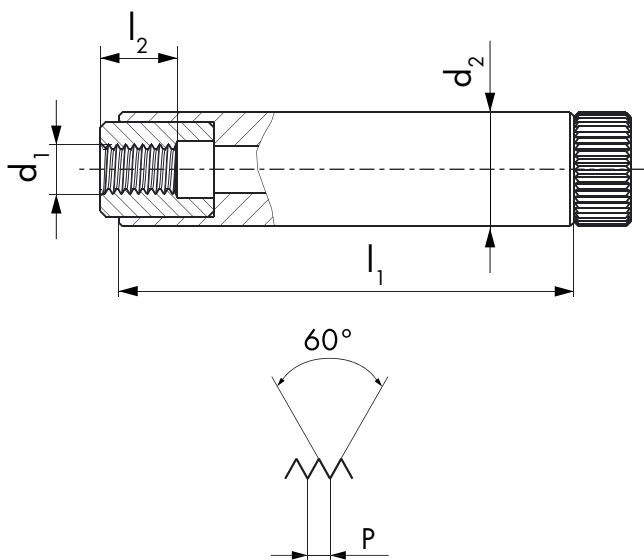

DN04 GO

DN14 NO-GO

DN04 GO

DN14 NO-GO



$\emptyset d_1$ UNC	P TPI	$\emptyset d_1$ mm	l_1 mm	l_2 GO mm	d_2 mm	ID	ID	ID	ID
1	64	1.854	24	2.78	6	● 191589	● 191592	● 191595	● 191598
2	56	2.184	24	3.28	6	● 191590	● 191593	● 191596	● 191599
3	48	2.515	24	3.77	6	● 191591	● 191594	● 191597	● 191600
$\emptyset d_1$ UNF	P TPI	$\emptyset d_1$ mm	l_1 mm	l_2 GO mm	d_2 mm	ID	ID	ID	ID
0	80	1.524	24	2.29	6	● 191653	● 191657	● 191661	● 191665
1	72	1.854	24	2.78	6	● 191654	● 191658	● 191662	● 191666
2	64	2.184	24	3.28	6	● 191655	● 191659	● 191663	● 191667
3	56	2.515	24	3.77	6	● 191656	● 191660	● 191664	● 191668



All nano ring gauges have a certificate of measurement, established with SCS certified plug check gauges. The paid certificate is available on request.

nano

DN01 GO

DN01 GO

DN02 NO-GO

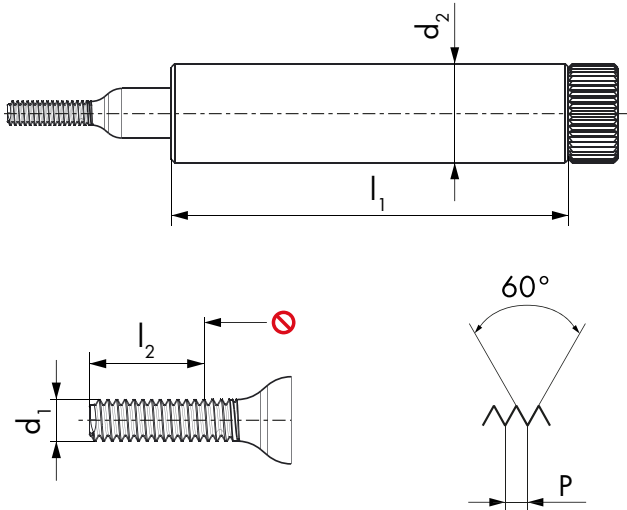

$\emptyset d_1$ S	P mm	l_1 mm	l_2 GO mm	d_2 mm	ID	ID	ID
0.3	0.08	24	0.9	6	● 190733	● 193242	● 190752
0.35	0.09	24	1.05	6	● 190734	● 193243	● 190753
0.4	0.1	24	1.2	6	● 190735	● 193244	● 190754
0.5	0.125	24	1.5	6	● 190736	● 193245	● 190755
0.6	0.15	24	1.8	6	● 190737	● 193246	● 190756
0.7	0.175	24	2.1	6	● 190738	● 193247	● 190757
0.8	0.2	24	2.4	6	● 190739	● 193248	● 190758
0.9	0.225	24	2.7	6	● 190740	● 193249	● 190759
1	0.25	24	3	6	● 190741	● 193250	● 190760
1.2	0.25	24	3.6	6	● 190742	● 193251	● 190761
1.4	0.3	24	4.2	6	● 190743	● 193252	● 190762



All nano thread plug gauges are SCS-certified and the paid certificate is available on request.

nano

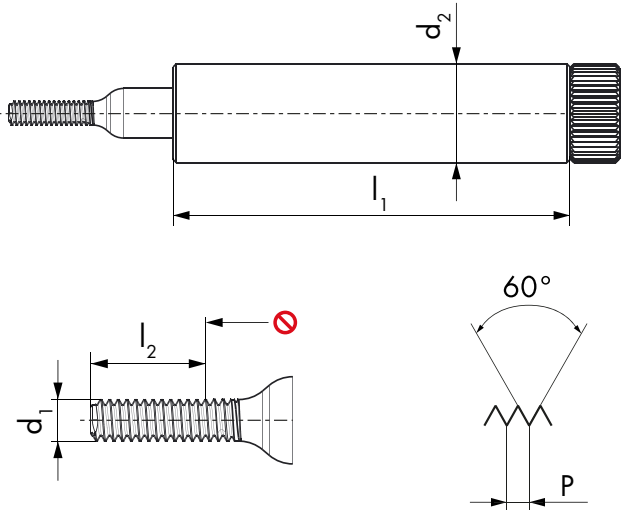

DN01 GO

DN02 NO-GO



$\emptyset d_1$ S	P mm	l_1 mm	l_2 GO mm	d_2 mm	ID	ID
0.3	0.08	24	0.9	6	● 190771	● 190790
0.35	0.09	24	1.05	6	● 190772	● 190791
0.4	0.1	24	1.2	6	● 190773	● 190792
0.5	0.125	24	1.5	6	● 190774	● 190793
0.6	0.15	24	1.8	6	● 190775	● 190794
0.7	0.175	24	2.1	6	● 190776	● 190795
0.8	0.2	24	2.4	6	● 190777	● 190796
0.9	0.225	24	2.7	6	● 190778	● 190797
1	0.25	24	3	6	● 190779	● 190798
1.2	0.25	24	3.6	6	● 190780	● 190799
1.4	0.3	24	4.2	6	● 190781	● 190800



All nano thread plug gauges are SCS-certified and the paid certificate is available on request.

nano

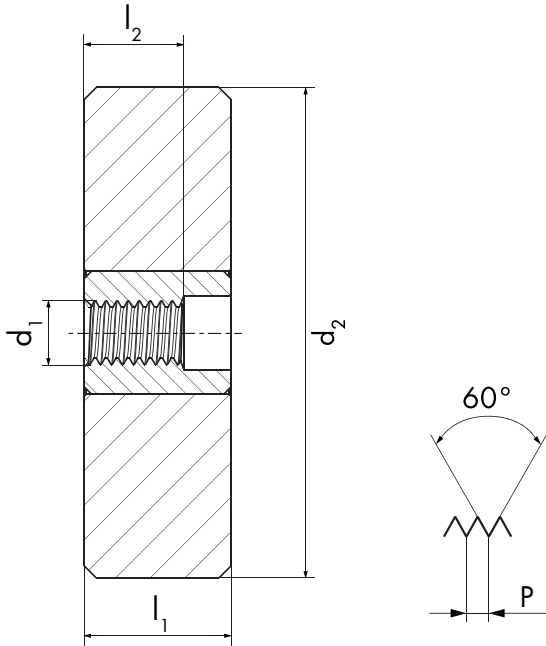

DZ04 GO

DZ14 NO-GO

DZ04 GO

DZ14 NO-GO



$\emptyset d_1$ S	P mm	l_1 mm	l_2 GO mm	d_2 mm	ID	ID	ID	ID
* 0.3	0.08	6	0.45	20	● 190809	● 190828	● 190847	● 190866
* 0.35	0.09	6	0.53	20	● 190810	● 190829	● 190848	● 190867
0.4	0.1	6	0.6	20	● 190811	● 190830	● 190849	● 190868
0.5	0.125	6	0.75	20	● 190812	● 190831	● 190850	● 190869
0.6	0.15	6	0.9	20	● 190813	● 190832	● 190851	● 190870
0.7	0.175	6	1.05	20	● 190814	● 190833	● 190852	● 190871
0.8	0.2	6	1.2	20	● 190815	● 190834	● 190853	● 190872
0.9	0.225	6	1.35	20	● 190816	● 190835	● 190854	● 190873
1	0.25	6	1.5	20	● 190817	● 190836	● 190855	● 190874
1.2	0.25	6	1.8	20	● 190818	● 190837	● 190856	● 190875
1.4	0.3	6	2.1	20	● 190819	● 190838	● 190857	● 190876

* In development



All nano ring gauges have a certificate of measurement, established with SCS certified plug check gauges. The paid certificate is available on request.

nano

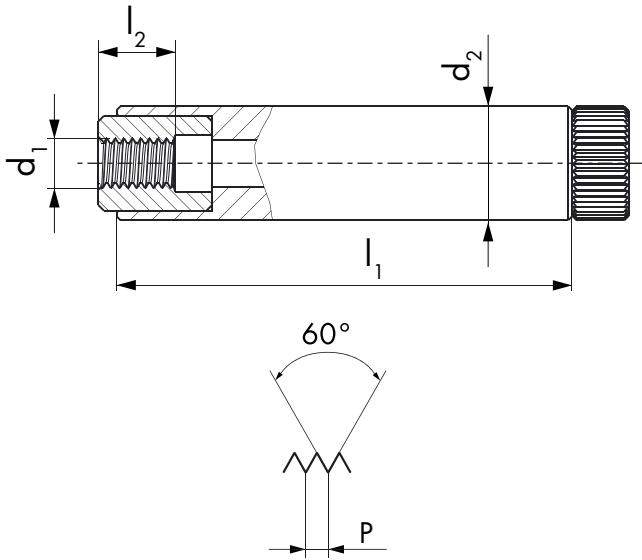

DN04 GO DN14 NO-GO DN04 GO DN14 NO-GO



$\emptyset d_1$ S	P mm	l_1 mm	l_2 GO mm	d_2 mm	ID	ID	ID	ID
* 0.3	0.08	24	0.45	6	● 190885	● 190904	● 190923	● 190942
* 0.35	0.09	24	0.53	6	● 190886	● 190905	● 190924	● 190943
0.4	0.1	24	0.6	6	● 190887	● 190906	● 190925	● 190944
0.5	0.125	24	0.75	6	● 190888	● 190907	● 190926	● 190945
0.6	0.15	24	0.9	6	● 190889	● 190908	● 190927	● 190946
0.7	0.175	24	1.05	6	● 190890	● 190909	● 190928	● 190947
0.8	0.2	24	1.2	6	● 190891	● 190910	● 190929	● 190948
0.9	0.225	24	1.35	6	● 190892	● 190911	● 190930	● 190949
1	0.25	24	1.5	6	● 190893	● 190912	● 190931	● 190950
1.2	0.25	24	1.8	6	● 190894	● 190913	● 190932	● 190951
1.4	0.3	24	2.1	6	● 190895	● 190914	● 190933	● 190952

*In development



All nano ring gauges have a certificate of measurement, established with SCS certified plug check gauges. The paid certificate is available on request.

nano

DN01 GO

DN01 GO

DN02 NO-GO

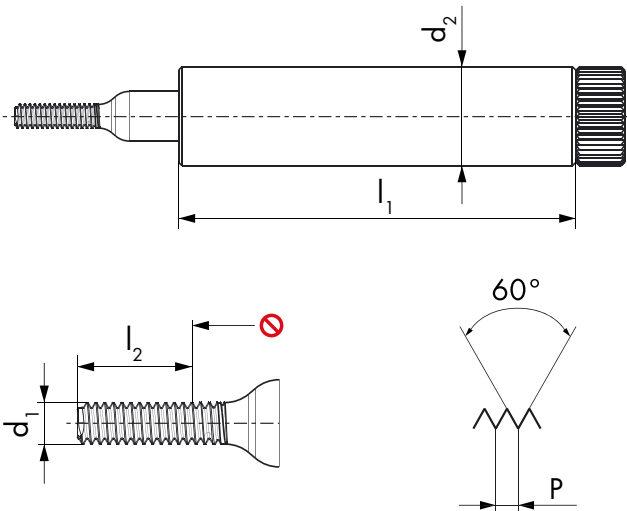

$\emptyset d_1$ SF	P mm	l_1 mm	l_2 GO mm	d_2 mm	ID	ID	ID
1.4	0.2	24	4.2	6	● 190744	● 193256	● 190763
1.6	0.2	24	3	6	● 190745	● 193257	● 190764
1.8	0.2	24	3	6	● 190746	● 193258	● 190765
2	0.2	24	3	6	● 190747	● 193259	● 190766
2.2	0.2	24	3	6	● 190748	● 193260	● 190767
2.2	0.25	24	3	6	● 190749	● 193261	● 190768
2.5	0.2	24	3	6	● 190750	● 193262	● 190769
2.5	0.25	24	3	6	● 190751	● 193263	● 190770



All nano thread plug gauges are SCS-certified and the paid certificate is available on request.

nano

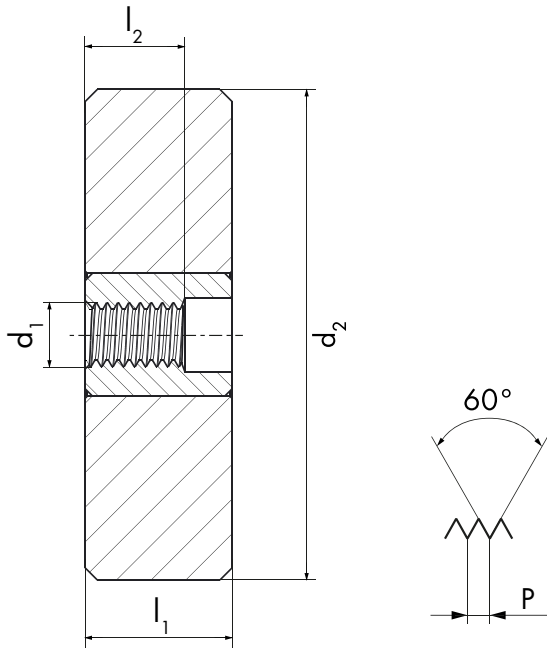

DZ04 GO

DZ14 NO-GO



$\emptyset d_1$ SF	P mm	l_1 mm	l_2 GO mm	d_2 mm	ID	ID
1.4	0.2	6	2.1	20	● 190820	● 190839
1.6	0.2	6	1.8	20	● 190821	● 190840
1.8	0.2	6	1.8	20	● 190822	● 190841
2	0.2	6	1.8	20	● 190823	● 190842
2.2	0.2	6	1.8	20	● 190824	● 190843
2.2	0.25	6	2.25	20	● 190825	● 190844
2.5	0.2	6	1.8	20	● 190826	● 190845
2.5	0.25	6	2.25	20	● 190827	● 190846



All nano ring gauges have a certificate of measurement, established with SCS certified plug check gauges. The paid certificate is available on request.

nano

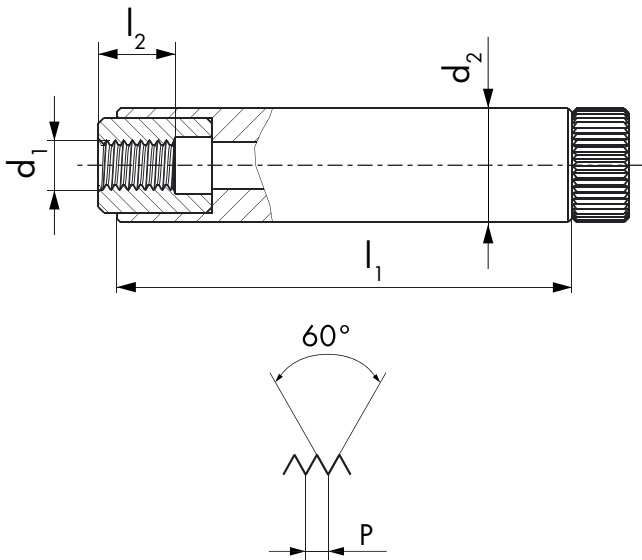

DN04 GO

DN14 NO-GO



$\emptyset d_1$ SF	P mm	l_1 mm	l_2 GO mm	d_2 mm	ID	ID
1.4	0.2	24	2.1	6	● 190896	● 190915
1.6	0.2	24	1.8	6	● 190897	● 190916
1.8	0.2	24	1.8	6	● 190898	● 190917
2	0.2	24	1.8	6	● 190899	● 190918
2.2	0.2	24	1.8	6	● 190900	● 190919
2.2	0.25	24	2.25	6	● 190901	● 190920
2.5	0.2	24	1.8	6	● 190902	● 190921
2.5	0.25	24	2.28	6	● 190903	● 190922



All nano ring gauges have a certificate of measurement, established with SCS certified plug check gauges. The paid certificate is available on request.

nano

DN01 GO

DN02 NO-GO

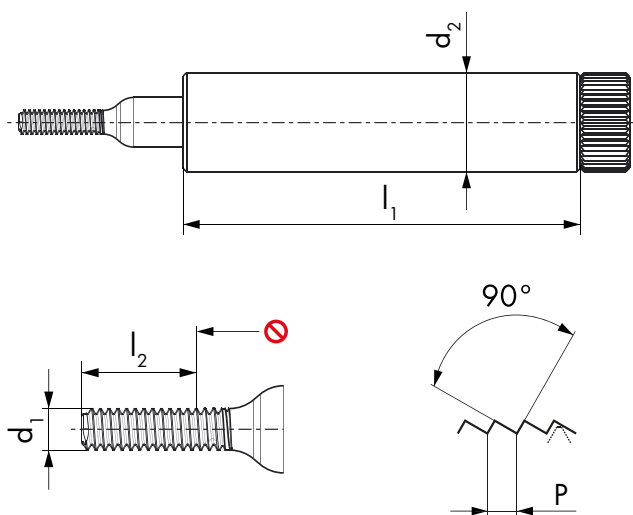

$\emptyset d_1$ SL	P mm	l_1 mm	l_2 GO mm	d_2 mm	ID	ID
0.5	0.1	24	1.5	6	● 600178	● 600186
0.6	0.125	24	1.8	6	● 600179	● 600187
0.7	0.15	24	2.1	6	● 600180	● 600188
0.8	0.15	24	2.4	6	● 600181	● 600189
0.9	0.175	24	2.7	6	● 600182	● 600190
1	0.2	24	3	6	● 600183	● 600191
1.2	0.2	24	3.6	6	● 600184	● 600192
1.4	0.25	24	4.2	6	● 600185	● 600193



All nano thread plug gauges are SCS-certified and the paid certificate is available on request.



ISO DIN 14 / ISO DIN 13
DC SWISS NI589 / ISO 1502



nano

RN05-1 GO

RN15-1 GO

RN05-1 GO

RN15-1 GO

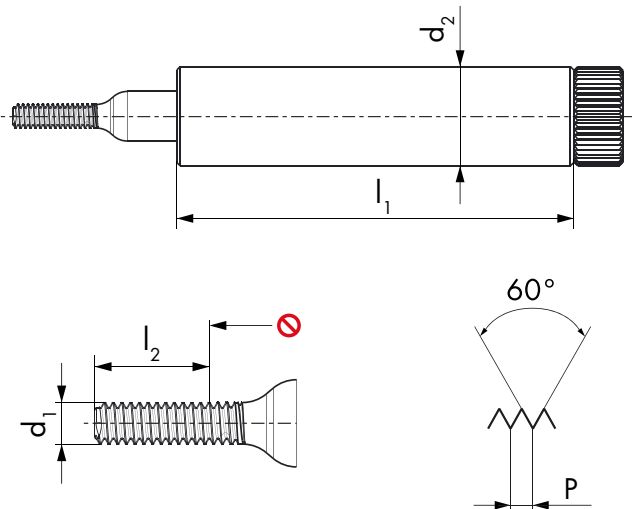

$\emptyset d_1$ M	P mm	l_1 mm	l_2 GO mm	d_2 mm	ID	ID	ID	ID
0.3	0.08	24	0.61	6	● 192884	● 192892		
0.35	0.09	24	0.71	6	● 192885	● 192893		
0.4	0.1	24	0.8	6	● 192886	● 192894		
0.5	0.125	24	1	6	● 192887	● 192895		
0.6	0.15	24	1.2	6	● 192888	● 192896		
0.7	0.175	24	1.4	6	● 192889	● 192897		
0.8	0.2	24	1.6	6	● 192890	● 192898		
0.9	0.225	24	1.8	6	● 192891	● 192899		
1	0.25	24	2	6			● 191499	● 191508
1.2	0.25	24	2.3	6			● 191500	● 191509
1.4	0.3	24	2.7	6			● 191501	● 191510

					ID	ID
					● 191517	● 191535

$\emptyset d_1$ M	P mm	l_1 mm	l_2 GO mm	d_2 mm	ID	ID
1.6	0.35	24	3.1	6	● 191517	● 191535
1.8	0.35	24	3.4	6	● 191518	● 191536
2	0.4	24	3.8	6	● 191519	● 191537
2.3	0.4	24	4.25	6	● 191520	● 191538
2.5	0.45	24	4.65	6	● 191521	● 191539
2.6	0.45	24	4.8	6	● 191522	● 191540



SCS certificate included.





ISO DIN 14 / ISO DIN 13
DC SWISS NI589 / ISO 1502



nano

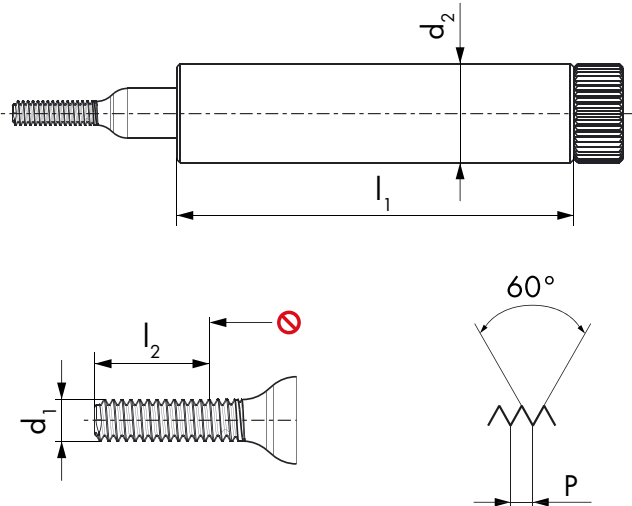

RN05-2
NO-GO

RN15-2
NO-GO

RN05-2
NO-GO

RN15-2
NO-GO



5h

5h

6h

6h

$\emptyset d_1$ M	P mm	l_1 mm	l_2 GO mm	d_2 mm
0.3	0.08	24	0.61	6
0.35	0.09	24	0.71	6
0.4	0.1	24	0.8	6
0.5	0.125	24	1	6
0.6	0.15	24	1.2	6
0.7	0.175	24	1.4	6
0.8	0.2	24	1.6	6
0.9	0.225	24	1.8	6
1	0.25	24	2	6
1.2	0.25	24	2.3	6
1.4	0.3	24	2.7	6

ID

ID

ID

ID

- 192900
- 192901
- 192902
- 192903
- 192904
- 192905
- 192906
- 192907

- 192908
- 192909
- 192910
- 192911
- 192912
- 192913
- 192914
- 192915

- 191502
- 191503
- 191504
- 191511
- 191512
- 191513

6g

6g

$\emptyset d_1$ M	P mm	l_1 mm	l_2 GO mm	d_2 mm
1.6	0.35	24	3.1	6
1.8	0.35	24	3.4	6
2	0.4	24	3.8	6
2.3	0.4	24	4.25	6
2.5	0.45	24	4.65	6
2.6	0.45	24	4.8	6

ID

ID

- 191523
- 191524
- 191525
- 191526
- 191527
- 191528
- 191541
- 191542
- 191543
- 191544
- 191545
- 191546



SCS certificate included.



ISO DIN 13
ISO 1502

VHM
CAR

nano

RN05-3
WEAR

RN15-3
WEAR

RN05-3
WEAR

RN15-3
WEAR

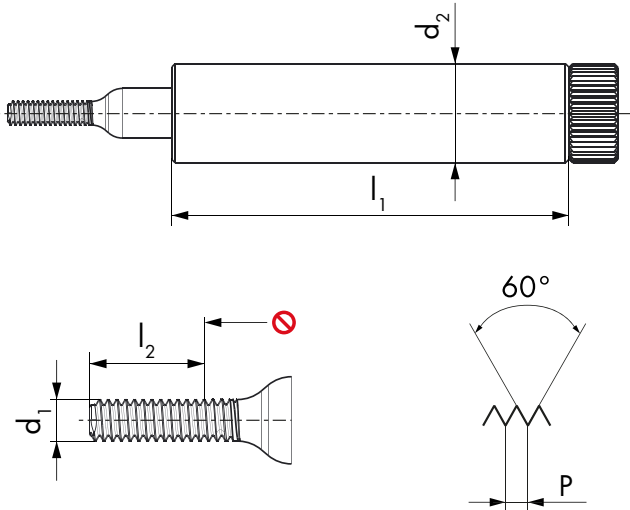

6h

6h

6g

6g

$\emptyset d_1$ M	P mm	l_1 mm	l_2 GO mm	d_2 mm	ID	ID	ID	ID
1	0.25	24	2	6	● 191505	● 191514		
1.2	0.25	24	2.3	6	● 191506	● 191515		
1.4	0.3	24	2.7	6	● 191507	● 191516		
1.6	0.35	24	3.1	6			● 191529	● 191547
1.8	0.35	24	3.4	6			● 191530	● 191548
2	0.4	24	3.8	6			● 191531	● 191549
2.3	0.4	24	4.25	6			● 191532	● 191550
2.5	0.45	24	4.65	6			● 191533	● 191551
2.6	0.45	24	4.8	6			● 191534	● 191552



SCS certificate included.



nano

RN05-1 GO

RN15-1 GO

RN05-1 GO

RN15-1 GO

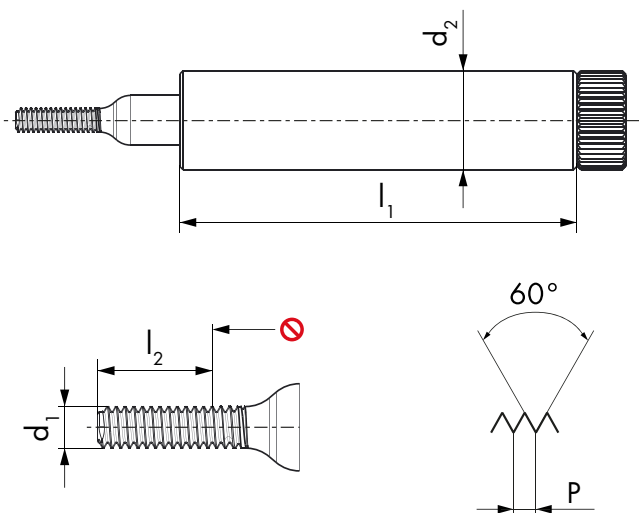

4h

4h

6h

6h

$\emptyset d_1$ MF	P mm	l_1 mm	l_2 GO mm	d_2 mm	ID	ID	ID	ID
1.4	0.2	24	2.5	6	● 191256	● 191298	● 192932	● 192945
1.6	0.2	24	2.2	6	● 195874	● 195876	● 192933	● 192946
1.8	0.2	24	2.2	6	● 197711	● 197712	● 192934	● 192947
2	0.2	24	2.2	6	● 197724	● 197725	● 192935	● 192948
2	0.25	24	2.75	6	● 197726	● 197727	● 192936	● 192949
2.2	0.2	24	2.2	6	● 197713	● 197714	● 192937	● 192950
2.2	0.25	24	2.75	6	● 197715	● 197716	● 192938	● 192951
2.3	0.2	24	2.2	6	● 197717	● 197718	● 192939	● 192952
2.3	0.25	24	2.75	6	● 197719	● 197720	● 192940	● 192953
2.5	0.2	24	2.2	6	● 197721	● 197722	● 192941	● 192954
2.5	0.25	24	2.75	6	● 190683	● 197723	● 192942	● 192955

6g

6g

$\emptyset d_1$ MF	P mm	l_1 mm	l_2 GO mm	d_2 mm	ID	ID
2.5	0.35	24	4.45	6	● 192943	● 192956
2.6	0.35	24	4.6	6	● 192944	● 192957



SCS certificate included.

nano

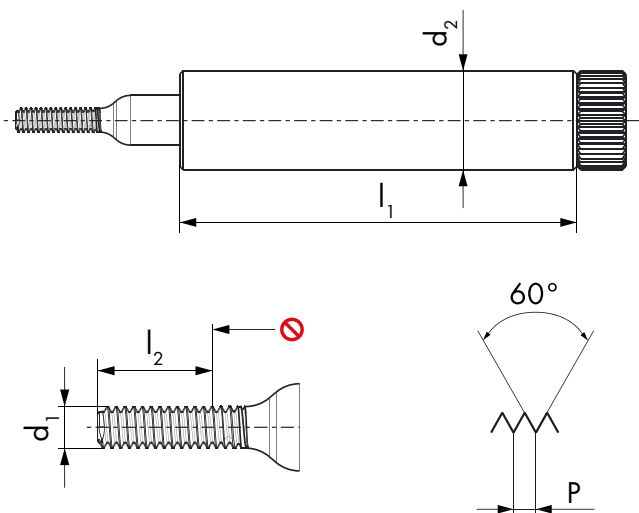

**RN05-2
NO-GO**

**RN15-2
NO-GO**

**RN05-2
NO-GO**

**RN15-2
NO-GO**



4h

4h

6h

6h

$\emptyset d_1$ MF	P mm	l_1 mm	l_2 GO mm	d_2 mm	ID	ID	ID	ID
1.4	0.2	24	2.5	6	● 191270	● 197728	● 192958	● 192971
1.6	0.2	24	1.6	6	● 195875	● 195877	● 192959	● 192972
1.8	0.2	24	1.6	6	● 197729	● 197730	● 192960	● 192973
2	0.2	24	1.6	6	● 199060	● 199061	● 192961	● 192974
2	0.25	24	2	6	● 199062	● 199063	● 192962	● 192975
2.2	0.2	24	1.6	6	● 197731	● 197732	● 192963	● 192976
2.2	0.25	24	2	6	● 197733	● 199364	● 192964	● 192977
2.3	0.2	24	1.6	6	● 199053	● 199054	● 192965	● 192978
2.3	0.25	24	2	6	● 199055	● 199056	● 192966	● 192979
2.5	0.2	24	1.6	6	● 199057	● 199058	● 192967	● 192980
2.5	0.25	24	2	6	● 190686	● 199059	● 192968	● 192981

6g

6g

$\emptyset d_1$ MF	P mm	l_1 mm	l_2 GO mm	d_2 mm	ID	ID
2.5	0.35	24	4.45	6	● 192969	● 192982
2.6	0.35	24	4.6	6	● 192970	● 192983



SCS certificate included.

nano

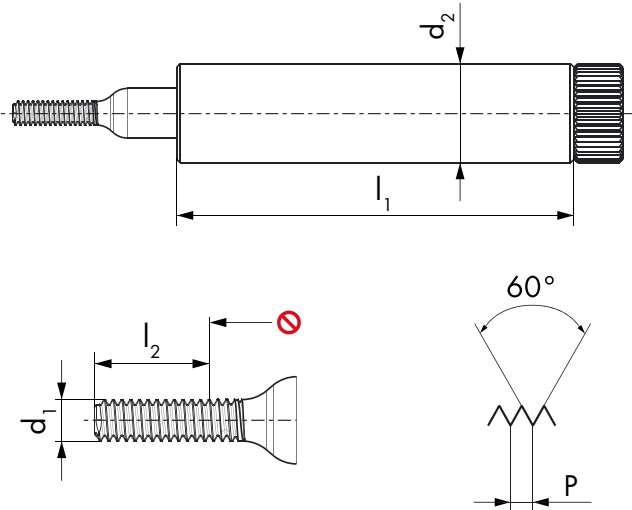

**RN05-3
WEAR**

**RN15-3
WEAR**

**RN05-3
WEAR**

**RN15-3
WEAR**



4h

4h

6h

6h

$\emptyset d_1$ MF	P mm	l_1 mm	l_2 G0 mm	d_2 mm	ID	ID	ID	ID
1.4	0.2	24	2.5	6	● 191284	● 191326	● 192984	● 192997
1.6	0.2	24	1.6	6	● 199064	● 199065	● 192985	● 192998
1.8	0.2	24	1.6	6	● 199066	● 199067	● 192986	● 192999
2	0.2	24	1.6	6	● 199360	● 199361	● 192987	● 193000
2	0.25	24	2	6	● 199362	● 199363	● 192988	● 193001
2.2	0.2	24	1.6	6	● 199068	● 199069	● 192989	● 193002
2.2	0.25	24	2	6	● 199070	● 199071	● 192990	● 193003
2.3	0.2	24	1.6	6	● 199072	● 199073	● 192991	● 193004
2.3	0.25	24	2	6	● 199074	● 199075	● 192992	● 193005
2.5	0.2	24	1.6	6	● 199076	● 199077	● 192993	● 193006
2.5	0.25	24	2	6	● 199358	● 199359	● 192994	● 193007
							6g	6g
$\emptyset d_1$ MF	P mm	l_1 mm	l_2 G0 mm	d_2 mm	ID	ID		
2.5	0.35	24	4.45	6			● 192995	● 193008
2.6	0.35	24	4.6	6			● 192996	● 193009



SCS certificate included.

UNC, UNF ASME B1.1 DC SWISS NI582

VHM
CAR

nano

RN05-1 GO

RN15-1 GO

RN05-1 GO

RN15-1 GO

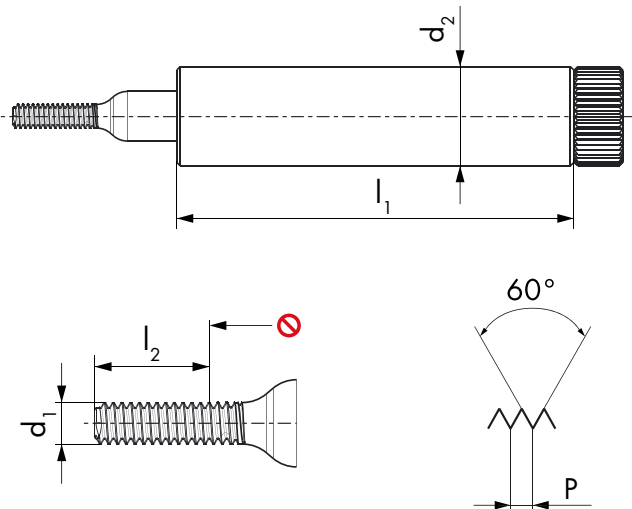

2A

2A

3A

3A

$\emptyset d_1$ UNC	P TPI	$\emptyset d_1$ mm	l_1 mm	l_2 GO mm	d_2 mm	ID	ID	ID	ID
1	64	1.854	24	3.58	6	● 191613	● 191619	● 191625	● 191631
2	56	2.184	24	4.18	6	● 191614	● 191620	● 191626	● 191632
3	48	2.515	24	4.83	6	● 191615	● 191621	● 191627	● 191633
						ID	ID	ID	ID
0	80	1.524	24	2.92	6	● 191685	● 191693	● 191701	● 191709
1	72	1.854	24	3.49	6	● 191686	● 191694	● 191702	● 191710
2	64	2.184	24	4.07	6	● 191687	● 191695	● 191703	● 191711
3	56	2.515	24	4.68	6	● 191688	● 191696	● 191704	● 191712



SCS certificate included.



UNC, UNF ASME B1.1 DC SWISS NI582

VHM
CAR

nano

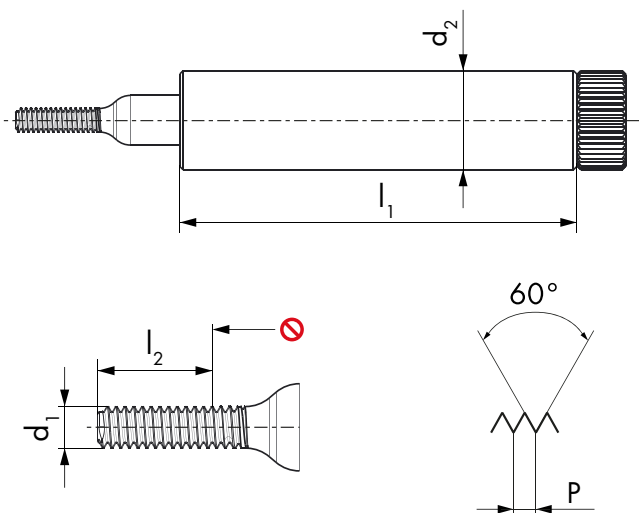

RN05-2
NO-GO

RN15-2
NO-GO

RN05-2
NO-GO

RN15-2
NO-GO



2A

2A

3A

3A

$\emptyset d_1$ UNC	P TPI	$\emptyset d_1$ mm	l_1 mm	l_2 GO mm	d_2 mm	ID	ID	ID	ID
1	64	1.854	24	3.58	6	● 191616	● 191622	● 191628	● 191634
2	56	2.184	24	4.18	6	● 191617	● 191623	● 191629	● 191635
3	48	2.515	24	4.83	6	● 191618	● 191624	● 191630	● 191636
$\emptyset d_1$ UNF	P TPI	$\emptyset d_1$ mm	l_1 mm	l_2 GO mm	d_2 mm	ID	ID	ID	ID
0	80	1.524	24	2.92	6	● 191689	● 191697	● 191705	● 191713
1	72	1.854	24	3.49	6	● 191690	● 191698	● 191706	● 191714
2	64	2.184	24	4.07	6	● 191691	● 191699	● 191707	● 191715
3	56	2.515	24	4.68	6	● 191692	● 191700	● 191708	● 191716



SCS certificate included.

nano

RN05-1 GO

RN15-1 GO

RN05-1 GO

RN15-1 GO

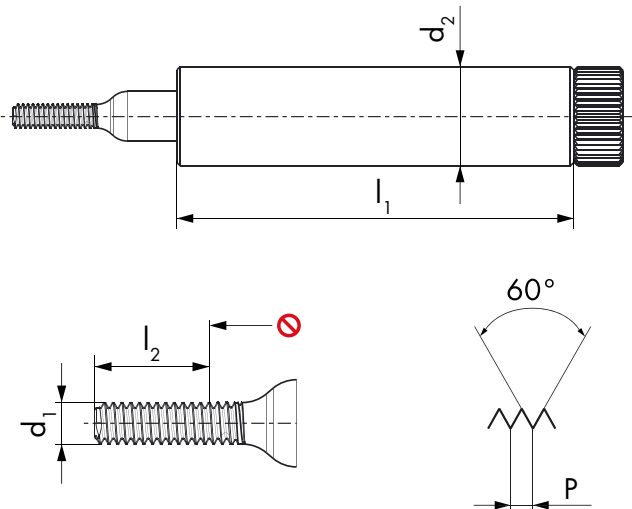

$\emptyset d_1$ S	P mm	l_1 mm	l_2 GO mm	d_2 mm	ID	ID	ID	ID
0.3	0.08	24	0.61	6	● 190961	● 190999	● 191037	● 191075
0.35	0.09	24	0.71	6	● 190962	● 191000	● 191038	● 191076
0.4	0.1	24	0.8	6	● 190963	● 191001	● 191039	● 191077
0.5	0.125	24	1	6	● 190964	● 191002	● 191040	● 191078
0.6	0.15	24	1.2	6	● 190965	● 191003	● 191041	● 191079
0.7	0.175	24	1.4	6	● 190966	● 191004	● 191042	● 191080
0.8	0.2	24	1.6	6	● 190967	● 191005	● 191043	● 191081
0.9	0.225	24	1.8	6	● 190968	● 191006	● 191044	● 191082
1	0.25	24	2	6	● 190969	● 191007	● 191045	● 191083
1.2	0.25	24	2.3	6	● 190970	● 191008	● 191046	● 191084
1.4	0.3	24	2.7	6	● 190971	● 191009	● 191047	● 191085



SCS certificate included.

nano

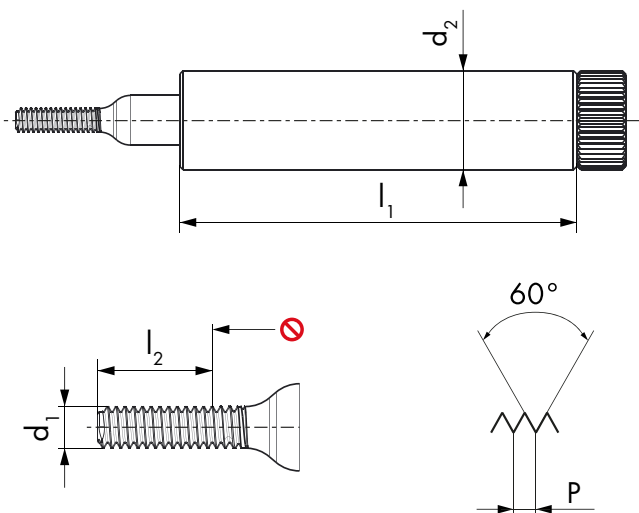

RN05-2
NO-GO

RN15-2
NO-GO

RN05-2
NO-GO

RN15-2
NO-GO



$\emptyset d_1$ S	P mm	l_1 mm	l_2 GO mm	d_2 mm	ID	ID	ID	ID
0.3	0.08	24	0.61	6	● 190980	● 191018	● 191056	● 191094
0.35	0.09	24	0.71	6	● 190981	● 191019	● 191057	● 191095
0.4	0.1	24	0.8	6	● 190982	● 191020	● 191058	● 191096
0.5	0.125	24	1	6	● 190983	● 191021	● 191059	● 191097
0.6	0.15	24	1.2	6	● 190984	● 191022	● 191060	● 191098
0.7	0.175	24	1.4	6	● 190985	● 191023	● 191061	● 191099
0.8	0.2	24	1.6	6	● 190986	● 191024	● 191062	● 191100
0.9	0.225	24	1.8	6	● 190987	● 191025	● 191063	● 191101
1	0.25	24	2	6	● 190988	● 191026	● 191064	● 191102
1.2	0.25	24	2.3	6	● 190989	● 191027	● 191065	● 191103
1.4	0.3	24	2.7	6	● 190990	● 191028	● 191066	● 191104



SCS certificate included.

nano

RN05-1 GO

RN15-1 GO

RN05-1 GO

RN15-1 GO

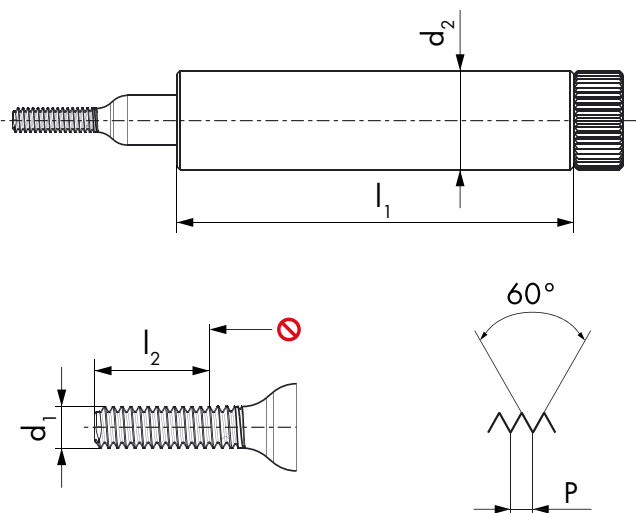

$\emptyset d_1$ SF	P mm	l_1 mm	l_2 GO mm	d_2 mm	ID	ID	ID	ID
1.4	0.2	24	2.5	6	● 190972	● 191010	● 191048	● 191086
1.6	0.2	24	2.2	6	● 190973	● 191011	● 191049	● 191087
1.8	0.2	24	2.2	6	● 190974	● 191012	● 191050	● 191088
2	0.2	24	2.2	6	● 190975	● 191013	● 191051	● 191089
2.2	0.2	24	2.2	6	● 190976	● 191014	● 191052	● 191090
2.2	0.25	24	2.75	6	● 190977	● 191015	● 191053	● 191091
2.5	0.2	24	2.2	6	● 190978	● 191016	● 191054	● 191092
2.5	0.25	24	2.75	6	● 190979	● 191017	● 191055	● 191093



SCS certificate included.

nano

**RN05-2
NO-GO**

**RN15-2
NO-GO**

**RN05-2
NO-GO**

**RN15-2
NO-GO**

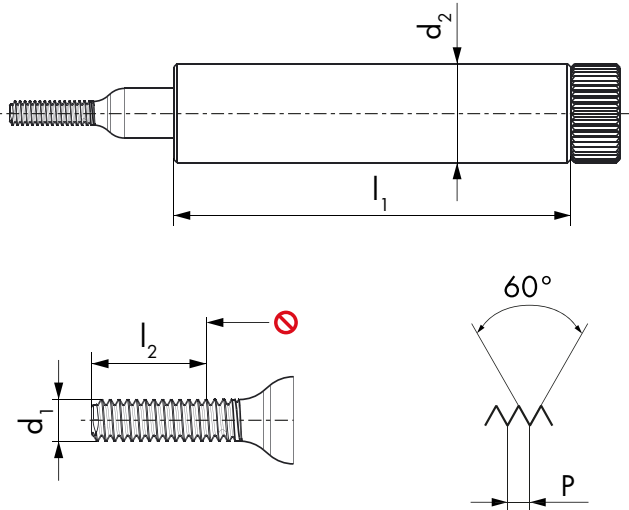

NIHS

NIHS

**NIHS
NT**

**NIHS
NT**

$\emptyset d_1$ SF	P mm	l_1 mm	l_2 GO mm	d_2 mm	ID	ID	ID	ID
1.4	0.2	24	2.5	6	● 190991	● 191029	● 191067	● 191105
1.6	0.2	24	1.6	6	● 190992	● 191030	● 191068	● 191106
1.8	0.2	24	1.6	6	● 190993	● 191031	● 191069	● 191107
2	0.2	24	1.6	6	● 190994	● 191032	● 191070	● 191108
2.2	0.2	24	1.6	6	● 190995	● 191033	● 191071	● 191109
2.2	0.25	24	2	6	● 190996	● 191034	● 191072	● 191110
2.5	0.2	24	1.6	6	● 190997	● 191035	● 191073	● 191111
2.5	0.25	24	2	6	● 190998	● 191036	● 191074	● 191112



SCS certificate included.

nano

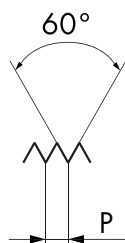
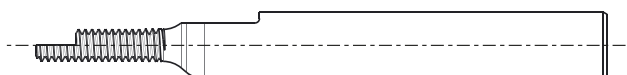
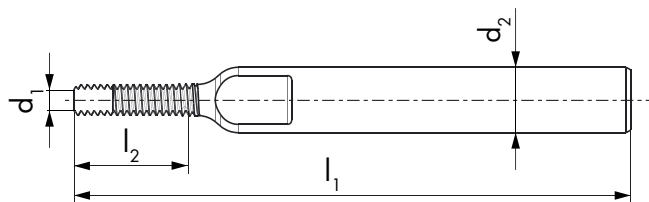

EN00



NIHS

$\varnothing d_1$ S	P mm	l_1 mm	l_2 GO mm	d_2 mm	ID
0.3	0.08	39	1.28	3	● 192747
0.35	0.09	39	1.44	3	● 192748
0.4	0.1	39	1.6	3	● 192749
0.5	0.125	39	2	3	● 192750
0.6	0.15	39	2.4	3	● 192751
0.7	0.175	39	2.8	3	● 192752
0.8	0.2	39	3.2	3	● 192753
0.9	0.225	39	3.6	3	● 192754
1	0.25	39	4	3	● 192755
1.2	0.25	39	4	3	● 192756
1.4	0.3	39	4.8	3	● 192757

Калибровочные резьбовые калибры SWISS используются для калибровки измерительных машин. Калибры из нашего каталога или изготовленные в соответствии с вашими конкретными требованиями поставляются с сертификатом измерения SCS. Это подтверждает, что процесс контроля во время производства был добросовестно соблюден в соответствии с ISO 17025. Это свидетельствует о качестве метрологического оборудования компании DC NANO TOOLS SA (SCS 0143), центра поверки и члена группы DC Group.

The DC SWISS calibration thread plug gauge is used for the calibration of measuring machines. The calibration gauges from our catalogue, or made to your specific requirements, are delivered with a SCS measurement certificate. This confirms that the control process during production has been conscientiously followed to ISO 17025. It attests to the quality of the metrological equipment of DC NANO TOOLS SA (SCS 0143), centre of competence and member of the DC Group.



SCS certificate included.

Зарегистрированная марка Micro-Safelock, принадлежащая DC SWISS, идентифицирует инструменты, используемые для системы Safelock, образующей резьбовой самоблокирующийся узел, разработанный и запатентованный DC SWISS.

Компоненты самоблокирующихся несимметричных винтовых узлов диаметром менее 1.5 мм не могут быть изготовлены с применением традиционных методов производства и измерения из-за особых требований к полям допусков для внутренней и наружной поверхностей резьбы.

Этот стандартный самоблокирующийся асимметричный резьбовой микроузел диаметром от 0.30 до 1.40 мм, который соответствует допускам, присущим резьбам микровинтов, был разработан и запатентован под названием Micro-Safelock. Он обеспечивает исключительную устойчивость к ударам и вибрациям, основываясь на технологии, используемой для более крупноразмерных узлов, а также имеет 30° наклон по внутренней резьбе (гайке), что облегчает крепление винта.

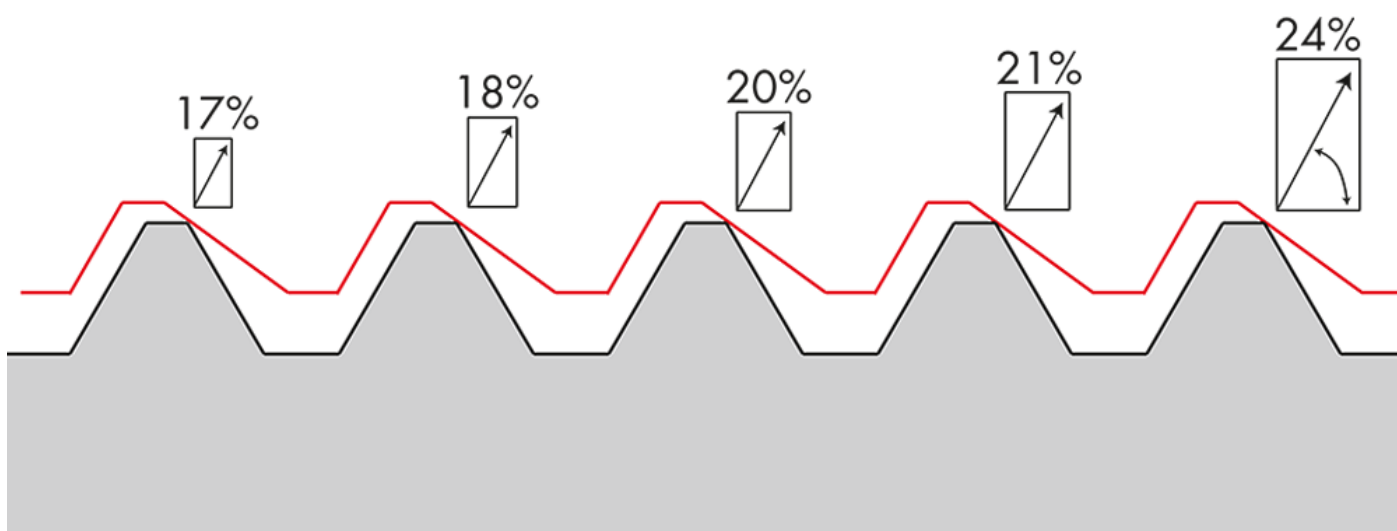

При приложении момента затяжки, растягивающая сила, действующая на винт, заставляет его автоматически центрироваться, и точки профиля винта вступают в контакт с краями асимметричного профиля внутренней резьбы (градиент), что приводит к тангенциальному контакту и равномерному распределению нагрузки по всем виткам резьбы.

Уменьшение нагрузки на первые несколько витков резьбы и направление напряжения на сжатие винта значительно снижает усталость, испытываемую парой винт/гайка, тем самым позволяя многократно собирать и разбирать узел без ухудшения его характеристик.

Чтобы соответствовать требованиям к размерам, сердечник винта был значительно усилен по сравнению с резьбой типа 60° N1HS или M того же размера.

Длина шага была уменьшена по сравнению со стандартом N1HS, чтобы увеличить площадь контакта между двумя фиксирующими элементами, при этом полезная длина осталась прежней. Это, очевидно, дает значительные преимущества, особенно при работе с мягкими материалами и винтами с малой головкой и уменьшенной длиной резьбы.

ПРЕИМУЩЕСТВА САМОБЛОКИРУЮЩЕЙСЯ СИСТЕМЫ

- Распределяет усилие растяжения по всей длине резьбы
- Номинальный блокирующий момент до 25% меньше, чем у обычной сборки
- Полностью механическая, без каких-либо химических добавок

ПРЕИМУЩЕСТВА ВИНТА

- Резьба с допусками, подобранными в соответствии с требованиями, обеспечивает непрерывный контакт между винтом и гайкой
- Мелкий шаг, увеличивающий поверхность контакта с гайкой при одинаковой длине резьбы
- Повышенный предел прочности благодаря внутреннему диаметру профиля, который на 19% больше (более 40% в сечении)
- Многократная сборка / разборка без изменения механических свойств

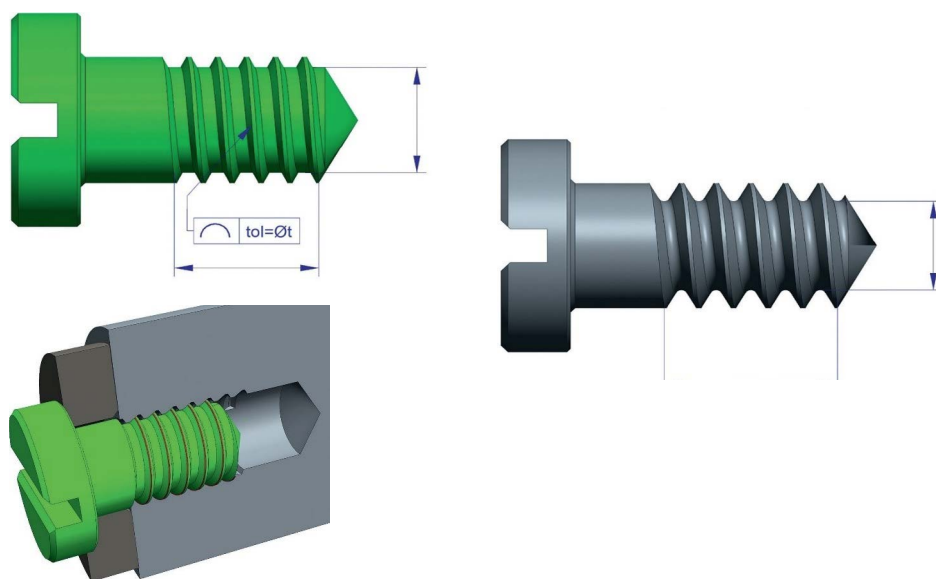

Многочисленные проведенные испытания на ударпрочность, ясно показывают, что резьбовые узлы полностью надежны и представляют собой убедительное решение для всех случаев, когда прочность винтового соединения должна быть обеспечена в особенно сложных условиях.

Моменты затяжки, приложенные к испытанным винтам, на 25% меньше значений, рекомендованных производителями химических резьбовых "покрытий-соединений".

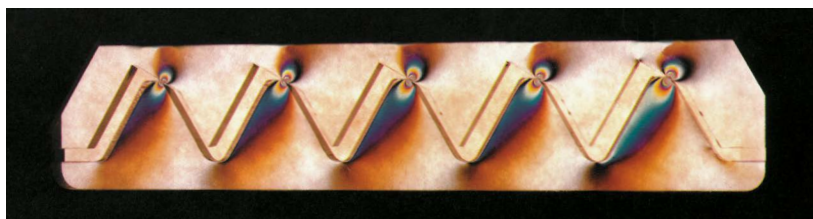
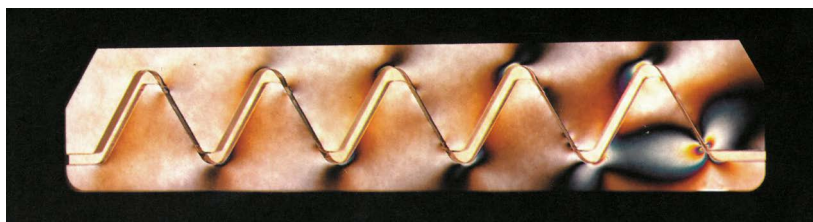

SAFELOCK РАЗМЕРЫ И СТАНДАРТЫ

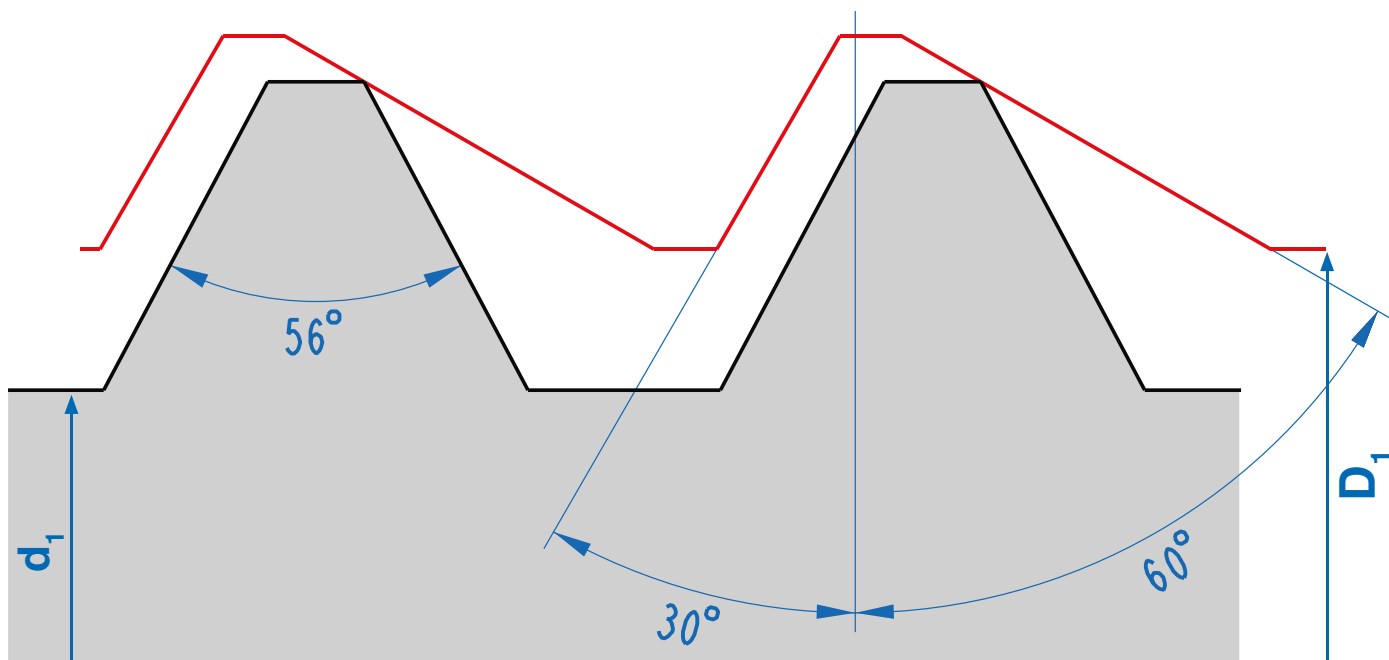

Размер	Шаг мм	d_1 mini mm	d_1 maxi mm	Угол профиля гайки	Угол профиля винта	d_1
SL 0.3	0.06	0.264	0.278	30°/60°	56°	0.247
SL 0.35	0.06	0.314	0.328	30°/60°	56°	0.297
SL 0.4	0.08	0.356	0.372	30°/60°	56°	0.331
SL 0.5	0.1	0.448	0.466	30°/60°	56°	0.416
SL 0.6	0.125	0.538	0.559	30°/60°	56°	0.496
SL 0.7	0.15	0.628	0.651	30°/60°	56°	0.576
SL 0.8	0.15	0.728	0.751	30°/60°	56°	0.676
SL 0.9	0.175	0.818	0.844	30°/60°	56°	0.756
SL 1.0	0.2	0.908	0.936	30°/60°	56°	0.836
SL 1.2	0.2	1.108	1.136	30°/60°	56°	1.036
SL 1.4	0.25	1.288	1.321	30°/60°	56°	1.197

MICRO SAFELOCK



The Micro-Safelock brand, registered and protected by DC SWISS, identifies the tools benefiting from the Safelock system guaranteeing the threaded self-locking assembly, developed and patented by DC SWISS.

For diameters of less than 1.5 mm, the requirements for the interior and exterior threading tolerance are such that conventional method for production and measurement do not permit the industrial production of components for conventional self-locking asymmetrical screw assemblies.

This standard self-locking asymmetrical threaded micro-assembly for diameters ranging from 0.30 to 1.40 mm, which adheres to the tolerances inherent in micro-screw threads, has been designed and patented under the name of Micro-Safelock. It offers exceptional performance in terms of resistance to shocks and vibrations, based on the technology used for larger-scale assemblies and fully integrating the 30° gradient into the interior thread (nut), making it easier to assemble the screw.

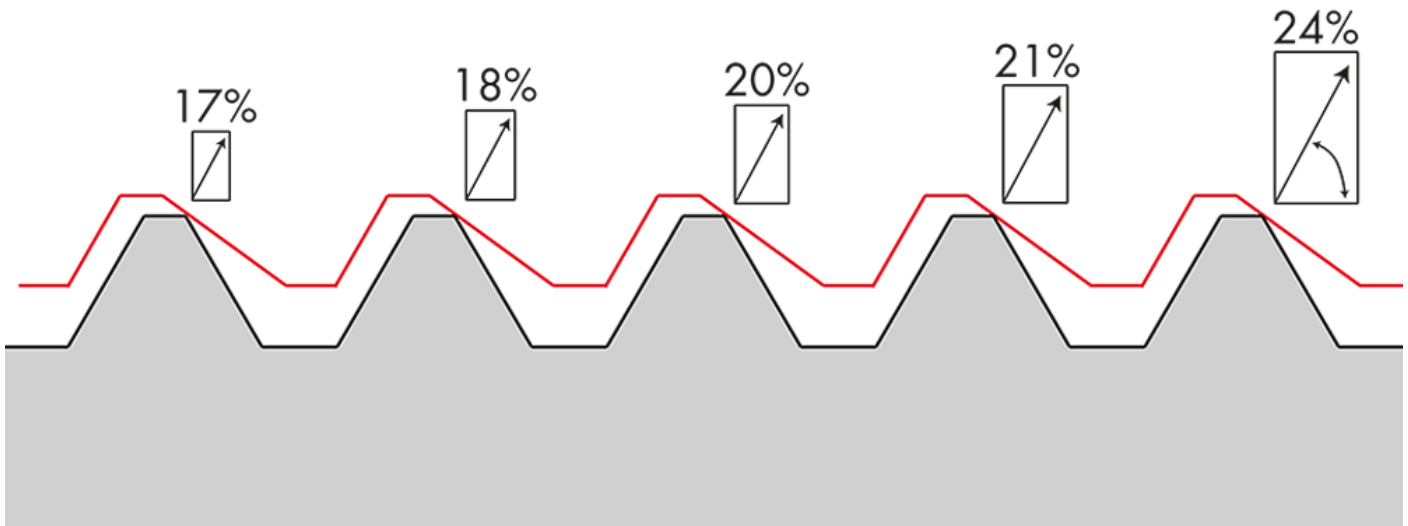

When tightening torque is applied, the tensile force exerted on the screw forces it to auto-centre, and the profile points of the screw come into contact with the edges of the asymmetrical profile of the interior screw thread (gradient), thus leading to tangential contact and a regular distribution of load across all the turns of the thread.

Reducing the load on the first few turns of the thread and directing the stress towards compressing the screw significantly reduces the fatigue experienced by the screw/nut assembly, thereby making it possible to assemble and disassemble it numerous times without changing its characteristics.

To correspond to the dimensional requirements, the core of the screw has been amply reinforced compared with a 60° NIHS or M type thread of the same dimension.

The length of the pitch has been reduced in comparison with the NIHS standard in order to increase the area of contact between the two fixing elements, with the usable length remaining the same. This obviously offers considerable advantages, particularly when working with soft materials and small-headed screws with a reduced thread length.

THE ADVANTAGES OF THE SELF-LOCKING

- Distributes the tensile force along the entire length of the screw thread
- Nominal blocking torque up to 25 % less than that of a conventional assembly
- Completely mechanical, with no chemical additives

THE ADVANTAGES OF THE SCREW

- Screw thread with tolerances tailored to meet requirements, enabling uninterrupted contact between screw and nut
- Fine pitch, increasing the surface in contact with the nut for the same length of thread
- Improved tensile strength thanks to an interior diameter of the profile that is 19 % greater (more than 40 % in section)
- Multiple assembly / disassembly with no change in mechanical properties

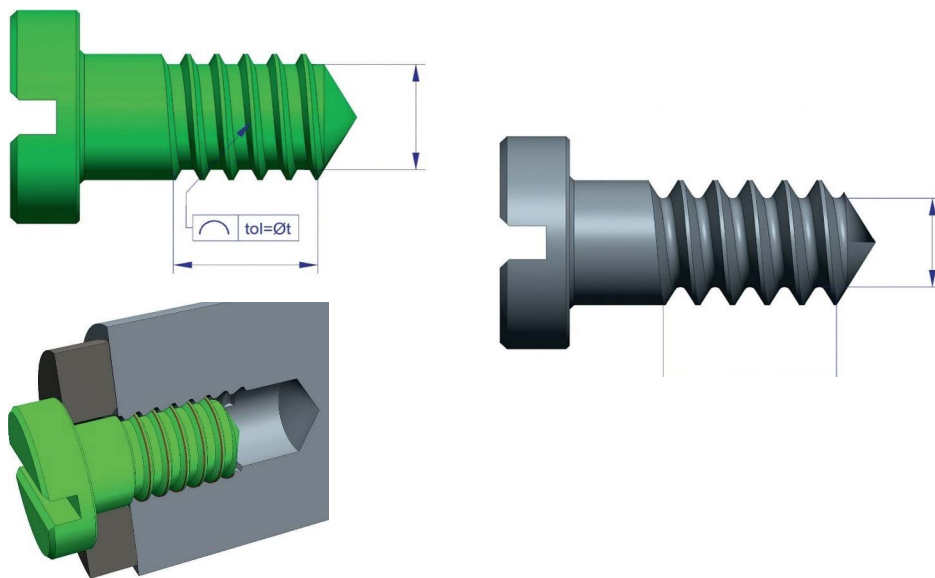

The numerous impact resistance tests that have been carried out, clearly show that the threaded assemblies are totally reliable and now offer a credible response to problems affecting screw resistance.

The tightening torques applied to specimen screws are 25 % less than the values recommended by manufacturers of chemical "threadlocking" coatings.

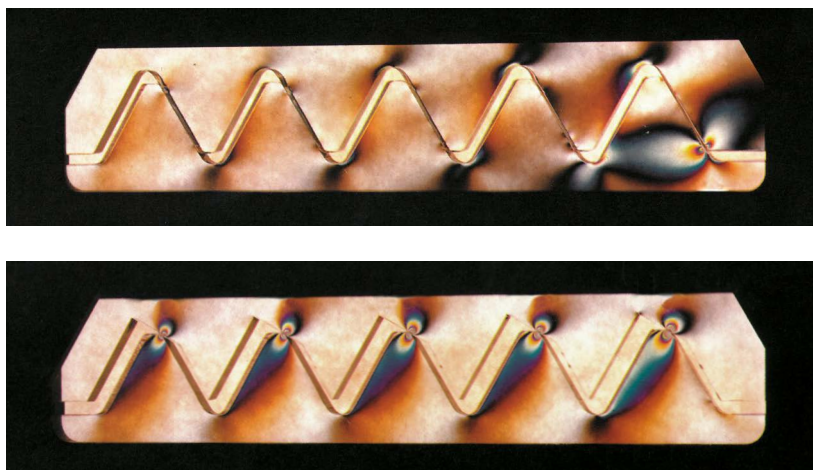

SAFELOCK DIMENSIONS AND STANDARDS

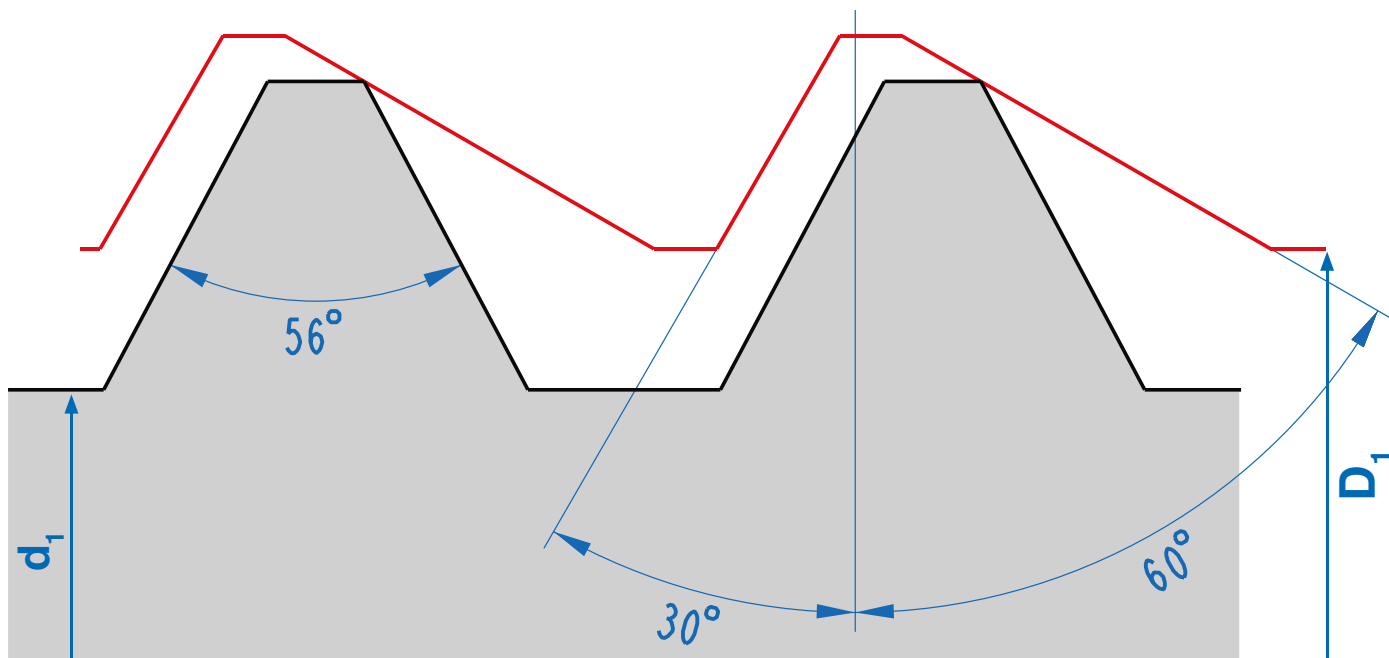

Dimension	Pitch mm	d_1 mini mm	d_1 maxi mm	Angles of sides of nut	Angles of sides of screw	d_1
SL 0.3	0.06	0.264	0.278	$30^\circ/60^\circ$	56°	0.247
SL 0.35	0.06	0.314	0.328	$30^\circ/60^\circ$	56°	0.297
SL 0.4	0.08	0.356	0.372	$30^\circ/60^\circ$	56°	0.331
SL 0.5	0.1	0.448	0.466	$30^\circ/60^\circ$	56°	0.416
SL 0.6	0.125	0.538	0.559	$30^\circ/60^\circ$	56°	0.496
SL 0.7	0.15	0.628	0.651	$30^\circ/60^\circ$	56°	0.576
SL 0.8	0.15	0.728	0.751	$30^\circ/60^\circ$	56°	0.676
SL 0.9	0.175	0.818	0.844	$30^\circ/60^\circ$	56°	0.756
SL 1.0	0.2	0.908	0.936	$30^\circ/60^\circ$	56°	0.836
SL 1.2	0.2	1.108	1.136	$30^\circ/60^\circ$	56°	1.036
SL 1.4	0.25	1.288	1.321	$30^\circ/60^\circ$	56°	1.197

ДОПУСКИ ДЛЯ РЕЗЬБЫ М И MF TOLERANCES FOR M AND MF THREADS

Резьба Гайки
Nut thread

Допуск 6H
— Цифра = степень точности
— Буква = основное отклонение
— Прописная буква = внутренняя резьба

Tolerance 6H
— Number = degree of accuracy
— Letter = tolerance position
— Capital letter = internal thread

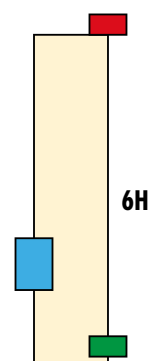
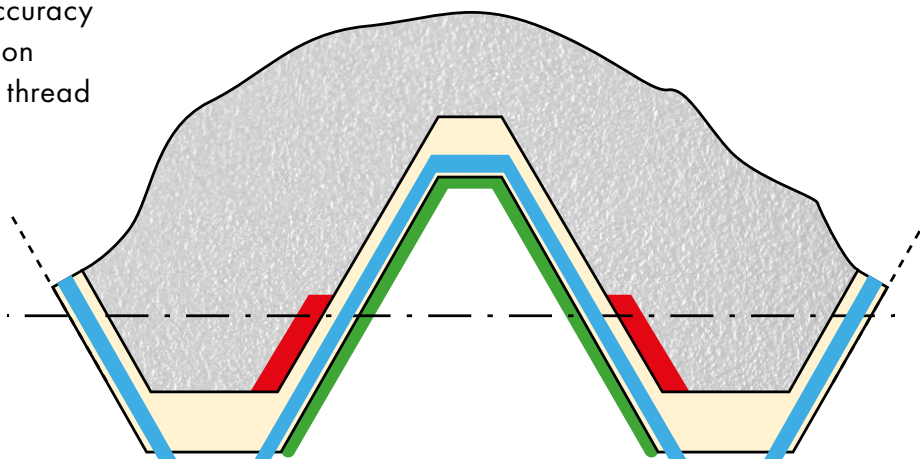

$H/h=0$

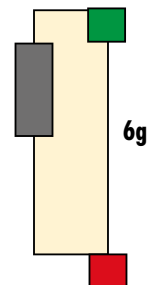
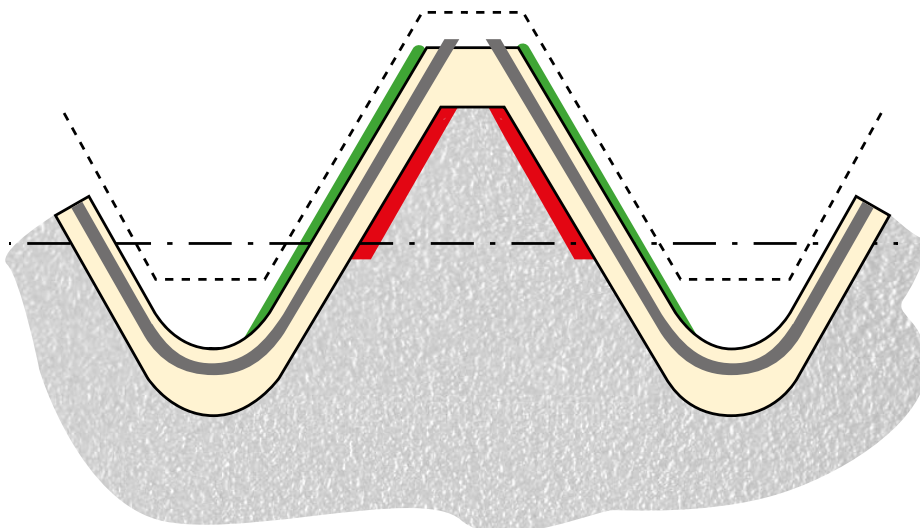

Резьба Болта
Bolt thread

Допуск 6g
— Цифра = степень точности
— Строчная буква = наружная резьба

Tolerance 6g
— Number = degree of accuracy
— Lowercase letter = external thread



ДОПУСКИ ДЛЯ РЕЗЬБЫ М И MF TOLERANCES FOR M AND MF THREADS

G=увеличенный
G = oversize

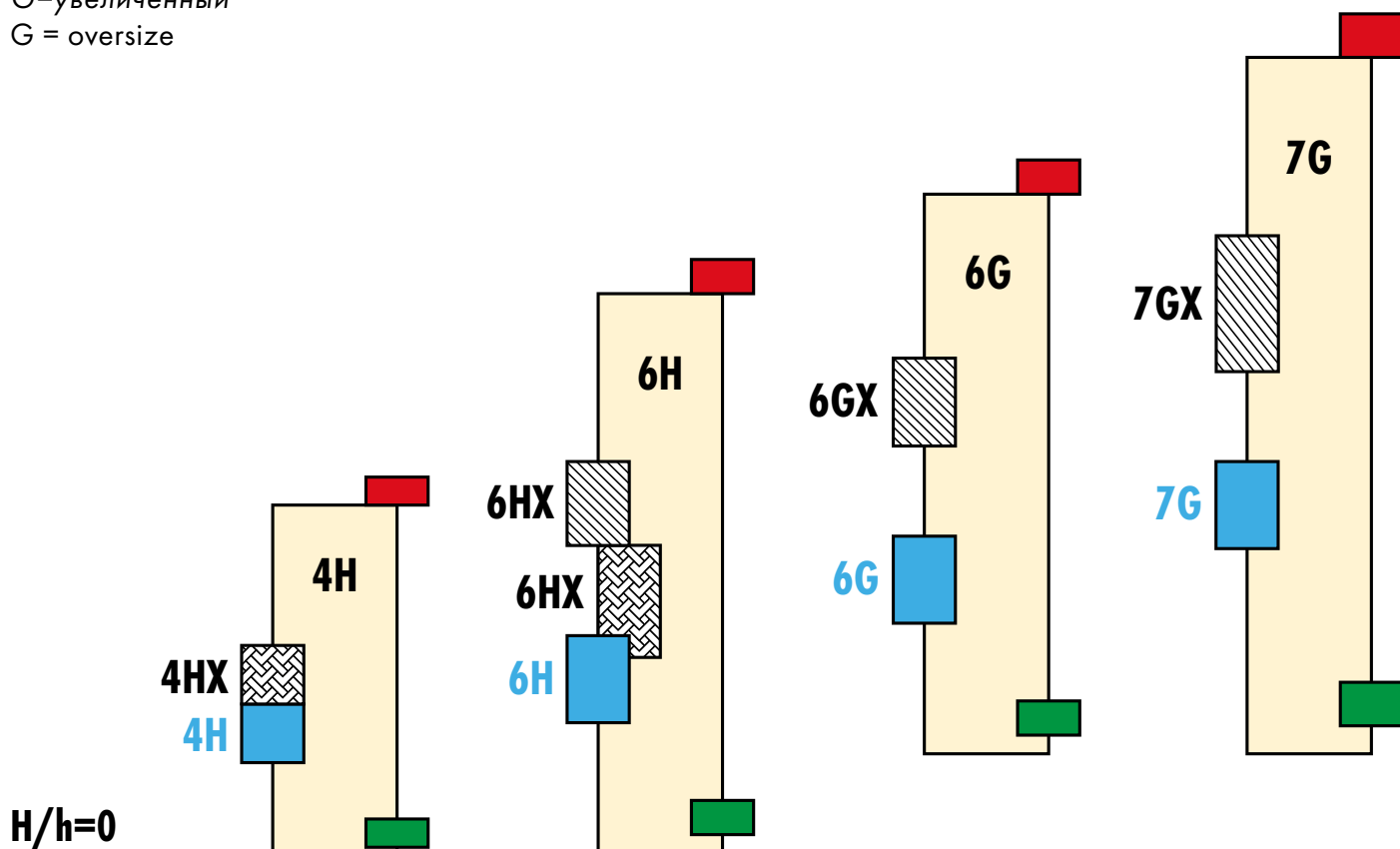

e=уменьшенный
e = undersize

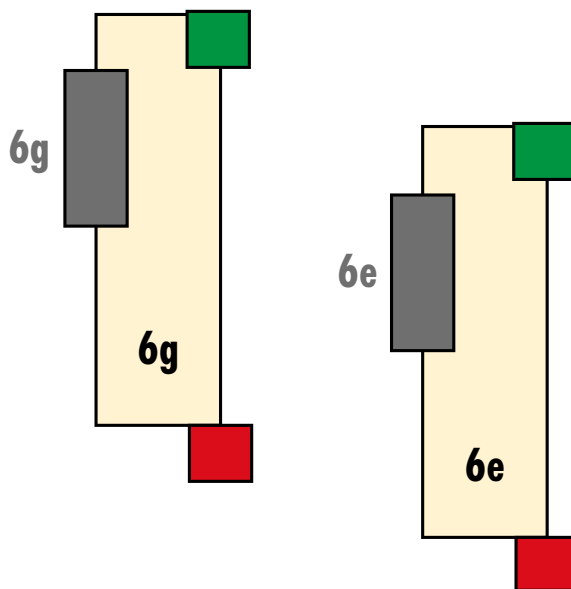

ОБОЗНАЧЕНИЯ ДОПУСКА ПО DIN EN 22857 ДЛЯ МЕТЧИКОВ С МЕТРИЧЕСКИМИ РЕЗЬБАМИ ПО ISO

Стандарт DIN 802, часть 1, был отозван и заменен DIN EN 22857

В таблице приведено сравнение между стандартом DIN EN 22857 и отозванным стандартом DIN 802, часть 1. Важным изменением является ре-классификация от классов точности метчиков к классам применения.

Классы применения по DIN EN 22857		Классы допуска по снятому стандарту DIN 802, часть 1.	Распределение зон допуска резьбы гайки, подлежащей нарезке				
Название	Код						
Класс 1	ISO 1	4H	4H	5H	-	-	-
Класс 2	ISO 2	6H	4G	5G	6H	-	-
Класс 3	ISO 3	6G	-	-	6G	7H	8H
	-	7G	-	-	-	7G	8G

Следует ожидать соответствующего переходного периода.

Коды для классов допуска 7G / 8G и зон допуска "X" еще не были стандартизированы в рамках DIN EN 22857, и значения из части 1 DIN 802 будут по-прежнему действительны.

TOLERANCE NOTATIONS TO DIN EN 22857 FOR TAPS WITH METRIC ISO THREADS

The standard DIN 802, part 1, has been withdrawn and replaced by DIN EN 22857.

The following chart gives a comparison between the standard DIN EN 22857 and the withdrawn standard DIN 802, part 1. An important change is the re-classification from tap tolerance classes to tap application classes.

Application classes for taps to DIN EN 22857		Tolerance classes to withdrawn standard DIN 802, part 1	Allotment of the tolerance zones of the nut thread to be cut				
Name	Code						
Class 1	ISO 1	4H	4H	5H	-	-	-
Class 2	ISO 2	6H	4G	5G	6H	-	-
Class 3	ISO 3	6G	-	-	6G	7H	8H
-	-	7G	-	-	-	7G	8G

A suitable transition period is to be expected.

Codes for tolerance classes 7G / 8G and the "X" tolerance zones have not yet been standardised within DIN EN 22857 and the values from DIN 802 part 1 will continue to be valid.

МЕТРИЧЕСКИЕ РЕЗЬБЫ ISO DIN 13

Номинальный диаметр резьбы - Средние диаметры

Номинальные диаметры резьбы	Шаг	Допуск	Резьба гайки		Допуск	Резьба болта	
			Средний диаметр			Средний диаметр	
			mini	maxi		maxi	mini
M 1	(x0.25)	4H	0.838	0.883	6h	0.838	0.785
M 1.4	(x0.3)	4H	1.205	1.253	6h	1.205	1.149
M 1.6	(x0.35)	6H	1.373	1.458	6g	1.354	1.291
M 2	(x0.4)	6H	1.740	1.830	6g	1.721	1.654
M 2	x0.25	4H	1.838	1.886	6h	1.838	1.782
M 2.2	(x0.45)	6H	1.908	2.003	6g	1.888	1.817
M 2.5	(x0.45)	6H	2.208	2.303	6g	2.188	2.117
M 3	(x0.5)	6H	2.675	2.775	6g	2.655	2.580
M 3	x0.35	6H	2.773	2.863	6g	2.754	2.687
M 3.5	(x0.6)	6H	3.110	3.222	6g	3.089	3.004
M 4	(x0.7)	6H	3.545	3.663	6g	3.523	3.433
M 4	x0.5	6H	3.675	3.775	6g	3.655	3.580
M 4.5	(x0.75)	6H	4.013	4.131	6g	3.991	3.901
M 5	(x0.8)	6H	4.480	4.605	6g	4.456	4.361
M 6	(x1)	6H	5.350	5.500	6g	5.324	5.212
M 6	x0.75	6H	5.513	5.645	6g	5.491	5.391
M 6	x0.5	6H	5.675	5.787	6g	5.655	5.570
M 7	(x1)	6H	6.350	6.500	6g	6.324	6.212
M 8	(x1.25)	6H	7.188	7.348	6g	7.160	7.042
M 10	(x1.5)	6H	9.026	9.206	6g	8.994	8.862
M 12	(x1.75)	6H	10.863	11.063	6g	10.829	10.679
M 12	x1.5	6H	11.026	11.216	6g	10.994	10.854
M 12	x1.25	6H	11.188	11.368	6g	11.160	11.028
M 12	x1	6H	11.350	11.510	6g	11.324	11.206
M 12	x0.75	6H	11.513	11.653	6g	11.491	11.385
M 12	x0.5	6H	11.675	11.793	6g	11.655	11.565
M 14	(x2)	6H	12.701	12.913	6g	12.663	12.503
M 16	(x2)	6H	14.701	14.913	6g	14.663	14.503
M 18	(x2.5)	6H	16.376	16.600	6g	16.334	16.164
M 20	(x2.5)	6H	18.376	18.600	6g	18.334	18.164
M 22	(x2.5)	6H	20.376	20.600	6g	20.334	20.164
M 24	(x3)	6H	22.051	22.316	6g	22.003	21.803
M 24	x2	6H	22.701	22.925	6g	22.663	22.493
M 24	x1.5	6H	23.026	23.226	6g	22.994	22.844
M 24	x1	6H	23.350	23.520	6g	23.324	23.199
M 27	(x3)	6H	25.051	25.316	6g	25.003	24.803
M 30	(x3.5)	6H	27.727	28.007	6g	27.674	27.462
M 33	(x3.5)	6H	30.727	31.007	6g	30.674	30.462
M 36	(x4)	6H	33.402	33.702	6g	33.342	33.118
M 39	(x4)	6H	36.402	36.702	6g	36.342	36.118
M 42	(x4.5)	6H	39.077	39.392	6g	39.014	38.778
M 45	(x4.5)	6H	42.077	42.392	6g	42.014	41.778
M 48	(x5)	6H	44.752	45.087	6g	44.681	44.431
M 48	x4	6H	45.402	45.717	6g	45.342	45.106
M 48	x3	6H	46.051	46.331	6g	46.003	45.791
M 48	x2	6H	46.701	46.937	6g	46.663	46.483
M 48	1.5	6H	47.026	47.238	6g	46.994	46.834
M 48	x1	6H	47.350	47.530	6g	47.324	47.184
M 52	(x5)	6H	48.752	49.087	6g	48.681	48.431
M 56	(x5.5)	6H	52.428	52.783	6g	52.353	52.088
M 60	(x5.5)	6H	56.428	56.783	6g	56.353	56.088
M 64	(x6)	6H	60.103	60.478	6g	60.023	59.743
M 68	(x6)	6H	64.103	64.478	6g	64.023	63.743

Другие диаметры/сочетания

Номинальные значения и допуски других метрических резьб ISO, не перечисленных в этой таблице, могут быть легко установлены для резьб того же шага путем сложения или вычитания разницы в номинальном диаметре: Например, номинальные значения и допуски для резьбы MF11 x 0,5 получаются простым добавлением 5 мм к значениям для резьбы MF6 x 0,5. Однако это правило применяется только в следующих диапазонах диаметров:

свыше 0.99 до 1.4 mm
свыше 1.4 до 2.8 mm
свыше 2.8 до 5.6 mm

свыше 5.6 до 11.2 mm
свыше 11.2 до 22.4 mm
свыше 22.4 до 45.0 mm

свыше 45 до 90 mm
свыше 90 до 180 mm
свыше 180 до 355 mm

METRIC THREADS ISO DIN 13

Nominal thread diameters - Pitch diameters

Nominal thread diameters	Pitch	Tol.	Nut thread Pitch diameters		Tol.	Bolt thread Pitch diameters	
			mini	maxi		maxi	mini
M 1	(x0.25)	4H	0.838	0.883	6h	0.838	0.785
M 1.4	(x0.3)	4H	1.205	1.253	6h	1.205	1.149
M 1.6	(x0.35)	6H	1.373	1.458	6g	1.354	1.291
M 2	(x0.4)	6H	1.740	1.830	6g	1.721	1.654
M 2	x0.25	4H	1.838	1.886	6h	1.838	1.782
M 2.2	(x0.45)	6H	1.908	2.003	6g	1.888	1.817
M 2.5	(x0.45)	6H	2.208	2.303	6g	2.188	2.117
M 3	(x0.5)	6H	2.675	2.775	6g	2.655	2.580
M 3	x0.35	6H	2.773	2.863	6g	2.754	2.687
M 3.5	(x0.6)	6H	3.110	3.222	6g	3.089	3.004
M 4	(x0.7)	6H	3.545	3.663	6g	3.523	3.433
M 4	x0.5	6H	3.675	3.775	6g	3.655	3.580
M 4.5	(x0.75)	6H	4.013	4.131	6g	3.991	3.901
M 5	(x0.8)	6H	4.480	4.605	6g	4.456	4.361
M 6	(x1)	6H	5.350	5.500	6g	5.324	5.212
M 6	x0.75	6H	5.513	5.645	6g	5.491	5.391
M 6	x0.5	6H	5.675	5.787	6g	5.655	5.570
M 7	(x1)	6H	6.350	6.500	6g	6.324	6.212
M 8	(x1.25)	6H	7.188	7.348	6g	7.160	7.042
M 10	(x1.5)	6H	9.026	9.206	6g	8.994	8.862
M 12	(x1.75)	6H	10.863	11.063	6g	10.829	10.679
M 12	x1.5	6H	11.026	11.216	6g	10.994	10.854
M 12	x1.25	6H	11.188	11.368	6g	11.160	11.028
M 12	x1	6H	11.350	11.510	6g	11.324	11.206
M 12	x0.75	6H	11.513	11.653	6g	11.491	11.385
M 12	x0.5	6H	11.675	11.793	6g	11.655	11.565
M 14	(x2)	6H	12.701	12.913	6g	12.663	12.503
M 16	(x2)	6H	14.701	14.913	6g	14.663	14.503
M 18	(x2.5)	6H	16.376	16.600	6g	16.334	16.164
M 20	(x2.5)	6H	18.376	18.600	6g	18.334	18.164
M 22	(x2.5)	6H	20.376	20.600	6g	20.334	20.164
M 24	(x3)	6H	22.051	22.316	6g	22.003	21.803
M 24	x2	6H	22.701	22.925	6g	22.663	22.493
M 24	x1.5	6H	23.026	23.226	6g	22.994	22.844
M 24	x1	6H	23.350	23.520	6g	23.324	23.199
M 27	(x3)	6H	25.051	25.316	6g	25.003	24.803
M 30	(x3.5)	6H	27.727	28.007	6g	27.674	27.462
M 33	(x3.5)	6H	30.727	31.007	6g	30.674	30.462
M 36	(x4)	6H	33.402	33.702	6g	33.342	33.118
M 39	(x4)	6H	36.402	36.702	6g	36.342	36.118
M 42	(x4.5)	6H	39.077	39.392	6g	39.014	38.778
M 45	(x4.5)	6H	42.077	42.392	6g	42.014	41.778
M 48	(x5)	6H	44.752	45.087	6g	44.681	44.431
M 48	x4	6H	45.402	45.717	6g	45.342	45.106
M 48	x3	6H	46.051	46.331	6g	46.003	45.791
M 48	x2	6H	46.701	46.937	6g	46.663	46.483
M 48	1.5	6H	47.026	47.238	6g	46.994	46.834
M 48	x1	6H	47.350	47.530	6g	47.324	47.184
M 52	(x5)	6H	48.752	49.087	6g	48.681	48.431
M 56	(x5.5)	6H	52.428	52.783	6g	52.353	52.088
M 60	(x5.5)	6H	56.428	56.783	6g	56.353	56.088
M 64	(x6)	6H	60.103	60.478	6g	60.023	59.743
M 68	(x6)	6H	64.103	64.478	6g	64.023	63.743

Other diameter/pitch combinations

The nominal and tolerance values of other metric ISO threads not listed in this chart can easily be established for threads of the same pitch by the addition or subtraction of the difference in the nominal diameter: E.G. the nominal and tolerance values for an MF11 x 0.5 thread are obtained by simply adding 5 mm to the values for the thread MF6 x 0.5. However, this rule only applies within the following diameter ranges:

over 0.99	to 1.4 mm	over 5.6	to 11.2 mm	over 45	to 90 mm
over 1.4	to 2.8 mm	over 11.2	to 22.4 mm	over 90	to 180 mm
over 2.8	to 5.6 mm	over 22.4	to 45.0 mm	over 180	to 355 mm

МЕТРИЧЕСКИЕ ISO РЕЗЬБЫ

Допуски среднего диаметра для метчиков

Номинальный Ø резьбы		Шаг	Классы точности	Нижнее значение	Верхнее значение	Номинальный Ø резьбы		Классы точности	Нижнее значение	Верхнее значение						
свыше	до	P				свыше	до				P					
0.99	1.4	0.2	ISO 1 / 4H	+ 5	+ 15	11.2	22.4	2.5	ISO 1 / 4H	+ 18	+ 54					
		0.25	ISO 1 / 4H	+ 6	+ 17			ISO 2 / 6H	+ 54	+ 90						
		0.3	ISO 1 / 4H	+ 6	+ 18			ISO 3 / 6G	+ 90	+ 126						
			ISO 2 / 6H	+ 18	+ 30			7G	+ 126	+ 162						
1.4	2.8	0.2	ISO 1 / 4H	+ 5	+ 15	22.4	45	1	ISO 1 / 4H	+ 13	+ 40					
		0.25	ISO 1 / 4H	+ 6	+ 18				ISO 2 / 6H	+ 40	+ 66					
		0.35	ISO 1 / 4H	+ 7	+ 20				ISO 3 / 6G	+ 66	+ 92					
			ISO 2 / 6H	+ 20	+ 34			7G	+ 92	+ 118						
		0.4	ISO 1 / 4H	+ 7	+ 21			1.5	ISO 1 / 4H	+ 16	+ 48					
			ISO 2 / 6H	+ 21	+ 36				ISO 2 / 6H	+ 48	+ 80					
0.45	ISO 1 / 4H		+ 8	+ 23	ISO 3 / 6G	+ 80	+ 112									
	ISO 2 / 6H	+ 23	+ 38	7G	+ 112	+ 144										
2.8	5.6	0.35	ISO 1 / 4H	+ 7	+ 21	2	90	2	ISO 1 / 4H	+ 18	+ 54					
			ISO 2 / 6H	+ 21	+ 36				ISO 2 / 6H	+ 54	+ 90					
		0.5	ISO 1 / 4H	+ 8	+ 24			3	ISO 3 / 6G	+ 90	+ 126					
			ISO 2 / 6H	+ 24	+ 40				7G	+ 126	+ 162					
			ISO 3 / 6G	+ 40	+ 55				3.5	ISO 1 / 4H	+ 22	+ 67				
		7G		+ 55	+ 70			ISO 2 / 6H		+ 67	+ 112					
		0.6	ISO 1 / 4H	+ 9	+ 27			4	ISO 3 / 6G	+ 106	+ 148					
			ISO 2 / 6H	+ 27	+ 45				7G	+ 148	+ 190					
		ISO 3 / 6G	+ 45	+ 63	4.5			ISO 1 / 4H	+ 25	+ 75						
			7G	+ 63				+ 81	ISO 2 / 6H	+ 75	+ 125					
		0.7	ISO 1 / 4H	+ 10	+ 29			45	90	1.5	ISO 3 / 6G	+ 125	+ 175			
			ISO 2 / 6H	+ 29	+ 48						7G	+ 175	+ 225			
		0.75	ISO 2 / 6H	+ 29	+ 48			5	ISO 1 / 4H	+ 17	+ 51					
			ISO 3 / 6G	+ 48	+ 67				ISO 2 / 6H	+ 51	+ 85					
0.8	8	ISO 1 / 4H	+ 10	+ 30	2	90	2	ISO 3 / 6G	+ 85	+ 119						
			ISO 2 / 6H	+ 30				+ 50	7G	+ 119	+ 153					
		ISO 3 / 6G	+ 50	+ 70			3	ISO 1 / 4H	+ 19	+ 57						
			7G	+ 70				+ 90	ISO 2 / 6H	+ 57	+ 95					
5.6	11.2	1	ISO 1 / 4H	+ 12	+ 35	45	90	1.5	ISO 3 / 6G	+ 95	+ 133					
			ISO 2 / 6H	+ 35	+ 59				7G	+ 133	+ 171					
			ISO 3 / 6G	+ 59	+ 83				2	ISO 1 / 4H	+ 22	+ 67				
				7G	+ 83					+ 107	ISO 2 / 6H	+ 67	+ 112			
		1.25	ISO 1 / 4H	+ 13	+ 38			3		ISO 3 / 6G	+ 112	+ 157				
			ISO 2 / 6H	+ 38	+ 63					7G	+ 157	+ 202				
			ISO 3 / 6G	+ 63	+ 88				4	ISO 1 / 4H	+ 25	+ 75				
				7G	+ 88					+ 113	ISO 2 / 6H	+ 75	+ 125			
		1.5	ISO 1 / 4H	+ 14	+ 42			5		ISO 3 / 6G	+ 125	+ 175				
			ISO 2 / 6H	+ 42	+ 70					7G	+ 175	+ 225				
			ISO 3 / 6G	+ 70	+ 98				5.5	ISO 1 / 4H	+ 27	+ 80				
				7G	+ 98					+ 126	ISO 2 / 6H	+ 80	+ 133			
		11.2	22.4	1	ISO 1 / 4H			+ 13		+ 38	6	90	1.5	ISO 3 / 6G	+ 133	+ 186
					ISO 2 / 6H			+ 38		+ 63				7G	+ 186	+ 239
ISO 3 / 6G	+ 63				+ 88	5.5	ISO 1 / 4H	+ 28	+ 84							
	7G				+ 88		+ 113	ISO 2 / 6H	+ 84	+ 140						
1.25	ISO 1 / 4H	+ 14	+ 42	6	ISO 3 / 6G		+ 140	+ 196								
	ISO 2 / 6H	+ 42	+ 70		7G		+ 196	+ 252								
	ISO 3 / 6G	+ 70	+ 98		6	ISO 1 / 4H	+ 30	+ 90								
		7G	+ 98			+ 126	ISO 2 / 6H	+ 90	+ 150							
1.5	ISO 1 / 4H	+ 15	+ 45	6		ISO 3 / 6G	+ 150	+ 210								
	ISO 2 / 6H	+ 45	+ 75			7G	+ 210	+ 270								
	ISO 3 / 6G	+ 75	+ 105		6	ISO 1 / 4H	+ 30	+ 90								
		7G	+ 105			+ 135	ISO 2 / 6H	+ 90	+ 150							
1.75	ISO 1 / 4H	+ 16	+ 48	6		ISO 3 / 6G	+ 150	+ 210								
	ISO 2 / 6H	+ 48	+ 80			7G	+ 210	+ 270								
	ISO 3 / 6G	+ 80	+ 112		6	ISO 1 / 4H	+ 30	+ 90								
		7G	+ 112			+ 144	ISO 2 / 6H	+ 90	+ 150							
2	ISO 1 / 4H	+ 17	+ 51	6		ISO 3 / 6G	+ 150	+ 210								
	ISO 2 / 6H	+ 51	+ 85			7G	+ 210	+ 270								
	ISO 3 / 6G	+ 85	+ 119		6	ISO 1 / 4H	+ 30	+ 90								
		7G	+ 119			+ 153	ISO 2 / 6H	+ 90	+ 150							

METRIC ISO THREADS

Pitch diameter tolerances for taps

Nominal thread Ø		Pitch	Tolerance classes	Lower limit	Upper limit	Nominal thread Ø		Pitch	Tolerance classes	Lower limit	Upper limit					
over	to	P				over	to	P								
0.99	1.4	0.2	ISO 1 / 4H	+ 5	+ 15	11.2	22.4	2.5	ISO 1 / 4H	+ 18	+ 54					
			ISO 1 / 4H	+ 6	+ 17				ISO 2 / 6H	+ 54	+ 90					
			ISO 1 / 4H	+ 6	+ 18				ISO 3 / 6G	+ 90	+ 126					
			ISO 2 / 6H	+ 18	+ 30				7G	+ 126	+ 162					
1.4	2.8	0.2	ISO 1 / 4H	+ 5	+ 15				22.4	45	1	ISO 1 / 4H	+ 13	+ 40		
			ISO 1 / 4H	+ 6	+ 18							ISO 2 / 6H	+ 40	+ 66		
			ISO 1 / 4H	+ 7	+ 20							ISO 3 / 6G	+ 66	+ 92		
			ISO 2 / 6H	+ 20	+ 34							7G	+ 92	+ 118		
			0.4	ISO 1 / 4H	+ 7							+ 21	1.5	ISO 1 / 4H	+ 16	+ 48
				ISO 2 / 6H	+ 21							+ 36		ISO 2 / 6H	+ 48	+ 80
0.45	ISO 1 / 4H	+ 8	+ 23	ISO 3 / 6G	+ 80							+ 112				
	ISO 2 / 6H	+ 23	+ 38	7G	+ 112							+ 144				
2.8	5.6	0.35	ISO 1 / 4H	+ 7	+ 21	2	ISO 1 / 4H	+ 18				+ 54				
			ISO 2 / 6H	+ 21	+ 36			ISO 2 / 6H				+ 54		+ 90		
		0.5	ISO 1 / 4H	+ 8	+ 24			ISO 3 / 6G				+ 90	+ 126			
			ISO 2 / 6H	+ 24	+ 40			7G				+ 126	+ 162			
			ISO 3 / 6G	+ 40	+ 55			3	ISO 1 / 4H	+ 21	+ 64					
		7G	+ 55	+ 70	ISO 2 / 6H				+ 64	+ 106						
		0.6	ISO 1 / 4H	+ 9	+ 27				ISO 3 / 6G	+ 106	+ 148					
			ISO 2 / 6H	+ 27	+ 45				7G	+ 148	+ 190					
		ISO 3 / 6G	+ 45	+ 63	3.5				ISO 1 / 4H	+ 22	+ 67					
			7G	+ 63					+ 81	ISO 2 / 6H	+ 67	+ 112				
		0.7	ISO 1 / 4H	+ 10				+ 29	ISO 3 / 6G	+ 112	+ 157					
			ISO 2 / 6H	+ 29				+ 48	7G	+ 157	+ 202					
0.75	ISO 2 / 6H	+ 29	+ 48	4		ISO 1 / 4H	+ 24	+ 71								
	ISO 3 / 6G	+ 48	+ 67			ISO 2 / 6H	+ 71	+ 118								
0.8	7G	+ 67	+ 86		ISO 3 / 6G	+ 118	+ 165									
	ISO 1 / 4H	+ 10	+ 30		7G	+ 165	+ 212									
	ISO 2 / 6H	+ 30	+ 50		4.5	ISO 1 / 4H	+ 25	+ 75								
ISO 3 / 6G	+ 50	+ 70	ISO 2 / 6H			+ 75	+ 125									
7G	+ 70	+ 90	ISO 3 / 6G	+ 125		+ 175										
5.6	11.2	1	ISO 1 / 4H	+ 12	+ 35	45	90	1.5	ISO 1 / 4H	+ 17	+ 51					
			ISO 2 / 6H	+ 35	+ 59				ISO 2 / 6H	+ 51	+ 85					
			ISO 3 / 6G	+ 59	+ 83				ISO 3 / 6G	+ 85	+ 119					
			7G	+ 83	+ 107				7G	+ 119	+ 153					
		1.25	ISO 1 / 4H	+ 13	+ 38				2	ISO 1 / 4H	+ 19	+ 57				
			ISO 2 / 6H	+ 38	+ 63					ISO 2 / 6H	+ 57	+ 95				
			ISO 3 / 6G	+ 63	+ 88					ISO 3 / 6G	+ 95	+ 133				
			7G	+ 88	+ 113					7G	+ 133	+ 171				
		1.5	ISO 1 / 4H	+ 14	+ 42					3	ISO 1 / 4H	+ 22	+ 67			
			ISO 2 / 6H	+ 42	+ 70						ISO 2 / 6H	+ 67	+ 112			
			ISO 3 / 6G	+ 70	+ 98				ISO 3 / 6G		+ 112	+ 157				
			7G	+ 98	+ 126				7G		+ 157	+ 202				
11.2	22.4	1	ISO 1 / 4H	+ 13	+ 38	4	ISO 1 / 4H	+ 25	+ 75							
			ISO 2 / 6H	+ 38	+ 63			ISO 2 / 6H	+ 75		+ 125					
			ISO 3 / 6G	+ 63	+ 88			ISO 3 / 6G	+ 125	+ 175						
			7G	+ 88	+ 113			7G	+ 175	+ 225						
		1.25	ISO 1 / 4H	+ 14	+ 42			5	ISO 1 / 4H	+ 27	+ 80					
			ISO 2 / 6H	+ 42	+ 70				ISO 2 / 6H	+ 80	+ 133					
			ISO 3 / 6G	+ 70	+ 98				ISO 3 / 6G	+ 133	+ 186					
			7G	+ 98	+ 126				7G	+ 186	+ 239					
		1.5	ISO 1 / 4H	+ 15	+ 45				5.5	ISO 1 / 4H	+ 28	+ 84				
			ISO 2 / 6H	+ 45	+ 75					ISO 2 / 6H	+ 84	+ 140				
			ISO 3 / 6G	+ 75	+ 105			ISO 3 / 6G		+ 140	+ 196					
			7G	+ 105	+ 135			7G		+ 196	+ 252					
1.75	ISO 1 / 4H	+ 16	+ 48	6	ISO 1 / 4H	+ 30	+ 90									
	ISO 2 / 6H	+ 48	+ 80		ISO 2 / 6H	+ 90	+ 150									
	ISO 3 / 6G	+ 80	+ 112		ISO 3 / 6G	+ 150	+ 210									
	7G	+ 112	+ 144		7G	+ 210	+ 270									
2	ISO 1 / 4H	+ 17	+ 51													
	ISO 2 / 6H	+ 51	+ 85													
	ISO 3 / 6G	+ 85	+ 119													
	7G	+ 119	+ 153													

ПОЛЕЗНЫЕ СОВЕТЫ ПРИ НАРЕЗАНИИ РЕЗЬБЫ

Оптимальные условия нарезания резьбы сокращают время обработки и увеличивают срок службы метчика.

Выбор наиболее подходящего метчика

Какие тип метчика и можно ли использовать раскатник, зависит от типа обрабатываемого материала.

Как общее руководство, материалы с относительным удлинением не менее 10% могут быть холодноформованы.

Для определения наиболее подходящего метчика, обращайтесь к таблице применимости DC.

Отверстия под резьбу

- Отверстия под резьбу должны быть очищены от стружки и грязи.
- Отверстия должны иметь предписанный размер, см. выдержку из диаграммы в технической части настоящего каталога, и в зависимости от фактического применения выбираться ближе к верхней границе диапазона.

Смазка по отношению к обрабатывающим центрам

Зачастую охлаждающие жидкости, используемые на обрабатывающих центрах, недостаточны для нарезания резьбы, поскольку процентное содержание смазки слишком низкое. Если нет возможности увеличить процентное содержание смазки в эмульсии, то проблему смазки можно решить другими способами, т. е.:

Смазка концентрированной эмульсией

- A. Смазочный блок, соединенный с управлением станком, подает в нужный момент определенное количество концентрированной эмульсии в отверстие или на метчик.
- B. Насос в отдельном резервуаре, управляемый станком, подает определенное количество концентрата в отверстие.

Нарезание резьбы в отдельных операциях

Эта процедура позволяет использовать идеальную смазку для нарезания резьбы.

Скорость резания для метчиков

Скорость резания оказывает большое влияние на отвод стружки и срок службы метчика. Поэтому стоит выбрать наиболее подходящую скорость резания при помощи испытаний. Рекомендации см. в таблицах применимости DC.

Скорость резания должна быть соотнесена с характеристиками обрабатываемого материала, станка и оснастки.

Влияние неправильной скорости резания:

- повышенные нагрузки
- сколы на заходной части метчика, вызванные перегрузкой режущего зуба
- рваная резьба
- низкая стойкость метчика
- проваленная резьба

ПОЛЕЗНЫЕ СОВЕТЫ ПРИ НАРЕЗАНИИ РЕЗЬБЫ

Налипание металла (холодная сварка)

Каковы причины налипания металла?

- Слишком высокая или слишком низкая скорость резания
- Неправильный выбор метчика
- Метчик с неадаптированной геометрией резания
- Охлаждающая жидкость, непригодная для материала
- Недостаточная смазка
- Осевое давление (или вытягивание) на метчик
- Недостаточный диаметр отверстия под резьбу
- Рваные стенки отверстия под резьбу
- Стружка в отверстии после сверления
- Ошибка центровки
- Ошибка соосности

Последствия налипания металла:

- рваные резьбы
- низкая стойкость метчика
- проваленные резьбы
- поломка инструмента
- бракованные детали

Крепление метчика

- Метчик должен быть закреплен соосно отверстию.
- На станках без синхронизации (подача/скорость), мы рекомендуем использовать резьбонарезной патрон.

Резьбонарезные головки

На станках без синхронизации (подача/скорость) подача должна программироваться, как правило, прим. на 5 - 10% меньше шага резьбы. В этих случаях нужно использовать резьбовой патрон который будет компенсировать разницу между значениями подачи и шага резьбы.

Важно, чтобы пружина натяжения в осевой компенсации была установлена на небольшое значение, чтобы избежать осевой нагрузки метчика.

Пружина сжатия, с другой стороны, должна быть натянута так, чтобы метчик начал резать, сжимая пружину не более чем на половину шага.

Важные советы:

Высокая жесткость станка и оснастки является необходимым условием для оптимального качества и производительности.

Убедитесь, что выбрана правильная скорость резания.

Убедитесь, что при нарезании резьбы используется достаточное количество СОЖ.

INTERESTING HINTS FOR TAPPING

Optimum tapping conditions reduce effective machining times and increase tap life.

Selection of the most suitable tap

Which types of tap or whether or not a thread former can be used, depends on the type of material to be machined.

As a general guide, materials with an extension of at least 10 % can be cold-formed.

To determine the most suitable tap, refer to the DC application charts.

Core holes

—Core holes should be clean and swarf-free.

—Core holes should be of the prescribed size, see chart extract in the technical part of this catalogue, and dependent on the actual application, selected towards the upper diameter limit.

Lubricant in relation to machining centers

Frequently the coolants used on machining centers are insufficient for tapping because their percentage lubricant content is too low. If it is not possible to increase the percentage of lubricant in the emulsion, the lubrication problem can be solved in other ways, i.e.:

Lubricating with concentrated emulsion

- A. A lubricating unit, connected to the machine control, delivers at the required instant a specific quantity of concentrated emulsion into the core hole or onto the tap.
- B. A pump in a separate tank, controlled by the machine, delivers a specific quantity of concentrate into the core hole.

Tapping in separate operations

This procedure allows the use of the ideal tapping lubricant.

Cutting speeds for taps

The cutting speed has a great influence on chip flow and the life time of the tap. It is therefore worthwhile to establish the ideal cutting speed by tapping trials. Guide values see on the DC application charts.

The cutting speed should be in relation to the characteristics of the material to be performed, the machine and its equipment.

Effects of unsuitable cutting speeds

- forced tapping
- tap lead chipping caused by overloaded cutting tooth
- torn threads
- unsatisfactory tap life
- rejected threads

INTERESTING HINTS FOR TAPPING

Cold welding

What are the causes of cold welding?

- Cutting speed too high or too low
- Unsuitable tap selection
- Tap with non-adapted cutting geometry
- Coolant unsuitable for material
- Insufficient coolant
- Axial pressure (pull or push) on the tap
- Core hole too small
- Torn core hole walls
- Drill chips in the hole
- Centering error
- Concentricity error

Effects of cold welding:

- torn threads
- short tap life
- rejected threads
- tool breakage
- scrap workpieces

Tap fitting

- The tap must be clamped axially to the core hole.
- On non-synchronized machines (feed/speed), we recommend the use of a tapping spindle.

Tapping heads

With non-synchronized machine spindles (feed/speed) the feed rate should, as a rule, be programmed approx. 5 - 10 % lower than the thread pitch. In these cases a tapping chuck must be used which will compensate the difference between the feed rate and the thread pitch.

It is important that the tension spring in the axial compensation is set to a light rate to avoid axially loading the tap.

The compression spring, on the other hand, should be tensioned so that the tap starts to cut by compressing the spring at the most up to one half pitch.

Important hints:

A good stability of machine and equipment is a prerequisite for optimum quality and performance.

Ensure that the correct cutting speed is selected.

Make sure that ample lubricating coolant is used when tapping.

ПРОБЛЕМЫ ПРИ НАРЕЗАНИИ И ИХ УСТРАНЕНИЕ

Проблема	Возможные причины	Устранение
Частичное выкрашивание метчика	Застывание стружки	Проверьте скорость резания. Используйте альтернативный тип метчика (K / N.62.-3 / Z.70VS).
	Метчик упирается в дно отверстия	Проверьте глубину отверстия и резьбы. Просверлите отверстие под резьбу глубже.
	Неравномерная структура материала заготовки	Отрегулируйте скорость резания. Повысьте концентрацию сож. Используйте метчик с другой геометрией / покрытием.
	Метчик неправильно переточен (заходный диаметр слишком мал, поэтому режущих зубьев слишком мало)	Убедитесь, что при перетачивании сохраняются исходные значения.

Проблема	Возможные причины	Устранение
Чрезмерный износ метчика	Неправильно выбрана скорость	Отрегулируйте скорость резания в соответствии с материалом заготовки. Воспользуйтесь метчиком с рекомендованным покрытием.
	Недостаточная насыщенность или количество сож	Обеспечьте использование подходящей охлаждающей жидкости в достаточном количестве. Убедитесь, что сож подается в зону резания.
	Упрочнение поверхности отверстия после сверления	Проверьте условия сверления отверстия (сверлите внимательно, избегая риска уплотнения поверхности). Проверьте режущие кромки сверла.
	Синхронизация	Проверьте состояние синхронизации. Избегайте жесткого нарезания резьбы в материалах с высокими механическими свойствами.

Проблема	Возможные причины	Устранение
Поломка метчика	Используется неправильный метчик (геометрия резания непригодна для применения)	Используйте метчик для соответствующей группы материалов.
	Плохой стружкоотвод	Выберите геометрию в соответствии с глубиной нарезаемой резьбы. При необходимости подберите длину канавок.
	Ошибка центрирования	Убедитесь, что оси метчика и отверстия совпадают.
	Метчик затупился	Переточите метчик. Убедитесь, что метчики хранятся в надлежащих условиях.
	Метчик упирается в дно отверстия	Используйте резьбонарезной патрон с осевой компенсацией и предохранительной муфтой.
	Слишком маленькое отверстие под резьбу	Выберите отверстие в соответствии с таблицей в технической части данного каталога.

ПРОБЛЕМЫ ПРИ НАРЕЗАНИИ И ИХ УСТРАНЕНИЕ

Проблема	Возможные причины	Устранение
Слишком большое резьбовое отверстие	Используется неправильный метчик (геометрия резания непригодна для применения)	Используйте метчик для соответствующей группы материалов.
	Нарушена соосность	Убедитесь, что оси метчика и отверстия совпадают.
	Налипание металла (холодная сварка)	Обеспечьте достаточную подачу сож в нужном направлении. Отрегулируйте скорость резания в соответствии с материалом заготовки. Воспользуйтесь метчиком с рекомендованным покрытием.
	Метчик неправильно переточен (заходная часть не концентрична)	Правильно заточите заходную часть метчика на подходящем шлифовальном станке.

Проблема	Возможные причины	Устранение
Рваная резьба	Используется неправильный метчик (геометрия резания непригодна для применения)	Используйте метчик для соответствующей группы материалов.
	скорость шпинделя и значение подачи не синхронизированы	Проверьте настройки программы (значения подачи и шага). Используйте резьбонарезную головку или резьбовой патрон с осевой компенсацией.
	Синхронизация	Проверьте состояние синхронизации Избегайте жесткого нарезания резьбы в материалах с высокими механическими свойствами.
	Недостаточное давление на метчик при врезании	Увеличить давление при врезании.

Проблема	Возможные причины	Устранение
Воронкообразное резьбовое отверстие	Неправильное давление на метчик при врезании	Используйте резьбонарезную головку с осевой компенсацией.

Проблема	Возможные причины	Устранение
Неудовлетворительное качество резьбовой поверхности	Используется неправильный метчик (геометрия резания непригодна для применения)	Используйте метчик для соответствующей группы материалов.
	Метчик тупой	Замените или переточите метчик.
	Метчик плохо переточен	Переточите метчик снова. Убедитесь, что геометрия метчика соответствует обрабатываемому материалу.
	Недостаточные насыщенность или количество сож	Обеспечьте использование подходящей охлаждающей жидкости в достаточном количестве.

APPLICATION AND USE OF THREADING TAPS

Problem	Causes	Solutions
Partial chipping of tap	Swarf jamming	Check cutting speed. Use alternative tap type (K / N.62.-3 / Z.70VS).
	Tap hits bottom of core hole	Check hole and thread depths. Drill core hole deeper.
	Irregular workpiece material structure	Adjust cutting speed. Improve lubricating quality of coolant. Use tap with other cutting geometry / other coating.
	Tap incorrectly re-ground (lead-in diameter too small, therefore too few cutting teeth)	Ensure that original values are maintained when re-grinding.

Problem	Causes	Solutions
Excessive tap wear	Incorrect cutting speed	Adjust cutting speed to suit workpiece material. Use tap with recommended surface coating.
	Coolant lacking in lubricating qualities and / or quantity	Ensure the use of a suitable coolant and an ample supply. Check that coolant is reaching the cutting zone.
	Surface of the core hole is compacted	Check core hole drilling conditions (drill carefully to reduce risk of surface compacting). Check drill cutting edges.
	Synchronization	Check status of synchronization. Avoid rigid tapping in materials with high mechanical properties.

Problem	Causes	Solutions
Tap breakage	Incorrect tap in use (cutting geometry unsuitable for application)	Use tap from the relevant material group.
	Bad swarf evacuation	Adapt cutting geometry to the depth to be tapped. Adapt length of flutes if necessary.
	Centering error	Ensure that axes of tap and core hole are aligned.
	Blunt tap	Re-grind tap. Ensure that taps are carefully stored.
	Tap has reached bottom of the core hole	Use tapping spindle with axial float and slipping clutch.
	Core hole too small	Select core hole as per chart in the technical part of this catalogue.

APPLICATION AND USE OF THREADING TAPS

Problem	Causes	Solutions
Tapped hole over-size	Incorrect tap in use (cutting geometry unsuitable for application)	Use tap selected from the relevant material group.
	Faulty alignment	Ensure that the tap is correctly aligned with the core hole axis.
	Cold welding	Improve lubrication and direction of coolant. Adjust cutting speed. Use taps with recommended surface treatment or coating.
	Re-ground tap (lead-in is not concentric)	Re-grind tap lead correctly on a suitable tap grinding machine.

Problem	Causes	Solutions
Stripped threads	Incorrect tap in use (cutting geometry incorrect for application)	Use a tap from the relevant material group.
	Spindle speed and feed rate not synchronized	Check feed rate programming and / or pitch of leading spindle. Use a tapping spindle with axial float or a tapping chuck with axial shock absorber.
	Synchronization	Check status of synchronization. Avoid rigid tapping in materials with high mechanical properties.
	Insufficient start pressure exerted on tap with peeling-cut	Increase start pressure.

Problem	Causes	Solutions
Bell mouthed tapped hole	Incorrect start pressure applied to tap	Use a tapping spindle with axial float.

Problem	Causes	Solutions
Unsatisfactory thread surface finish	Incorrect tap in use (cutting geometry unsuitable for application)	Select tap from the relevant material group.
	The tap is blunt	Replace or re-grind tap.
	Tap badly re-ground	Re-grind tap again. Check that cutting geometry is suitable for material.
	Coolant lacking in lubricating qualities and / or quantity	Ensure the use of a suitable coolant and an ample supply.

ТАБЛИЦА ПРИМЕНЕНИЯ — APPLICATION CHART

Нарезание резьбы
Thread cutting

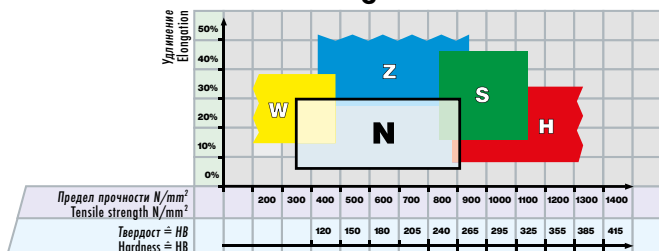

Нарезание резьбы
Thread cutting

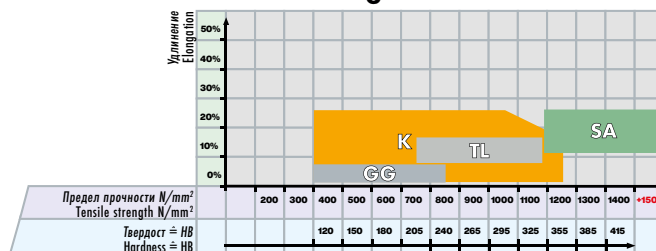

DC Классификация материалов

DC Material classification

Группы материалов Material groups	Обозначение материалов	Material designation	Твердость Hardness (HB)	Предел прочности Tensile strength Rm (N/mm ²)	Удлинение Elongation A (%)
10 Стали Steels	11	Легко обрабатываемые стали	< 200	< 700	< 10
	12	Структурные, цементуемые стали	< 200	< 700	< 30
	13	Углеродистые стали	< 300	< 1000	< 20
	14	Легированные стали < 850 N/mm ²	< 250	< 850	< 30
	15	Легированные стали закал./отп. > 850 - < 1150 N/mm ²	> 250	> 850	< 30
	16	Высокопрочные легированные стали ≤ 44 HRC	> 250	> 850	< 12
	17	Закалённые легированные стали > 44 - ≤ 54 HRC	> 410	> 1400	< 2
	18	Закалённые легированные стали > 54 - ≤ 63 HRC	> 560	> 1980	< 2
20 Нержавеющие стали Stainless steels	21	Легко обрабатываемые нержавеющие стали	< 250	< 850	< 25
	22	Аустенитные нержавеющие стали	< 250	< 850	> 20
	23	Ферритные и мартенситные < 850 N/mm ²	< 250	< 850	> 20
	24	Ферритные и мартенситные > 850 - < 1150 N/mm ²	> 250	> 850	> 15
30 Чугун Cast iron	31	Чугун	< 250	< 850	< 10
	32	Высокопрочные и ковкий чугун	< 250	< 850	> 10
40 Титан Titanium	41	Чистый титан	< 250	< 850	> 20
	42	Титановые сплавы	> 250	> 850	< 20
50 Никель Nickel	51	Никелевые сплавы 1 ≤ 850 N/mm ²	< 250	< 850	> 25
	52	Никелевые сплавы 2 > 850 - ≤ 1150 N/mm ²	> 250	> 850	< 25
	53	Никелевые сплавы 3 > 1150 - ≤ 1600 N/mm ²	> 340	> 1150	< 20
60 Медь Copper	61	Медь чистая (электротехническая)	< 120	< 400	> 12
	62	Короткопружечная латунь, фосфористая бронза	< 200	< 700	< 12
	63	Длиннопружечная латунь	< 200	< 700	> 12
	64	безсвинцовая латунь	< 220	< 700	> 15
70 Алюминий Магний Aluminium Magnesium	71	Алюминий чистый	< 100	< 350	> 15
	72	Алюминиевые сплавы Si < 1.5 %	< 150	< 500	> 15
	73	Алюминиевые сплавы Si > 1.5 % - < 10 %	< 120	< 400	< 15
	74	Алюминиевые сплавы Si > 10 %, магниевые сплавы	< 120	< 400	< 10
80 Пластики Plastic compounds	81	Термопластики	-	-	-
	82	Дюропластики	-	-	-
	83	Пластики армированные стекловолокном	-	-	-
90 Драгоценные металлы Precious metals	91	Желтое золото	-	-	-
	92	Красное золото	-	-	-
	93	Белое золото	-	-	-
	94	Серебро	-	-	-

НАРЕЗАНИЕ РЕЗЬБЫ — CLASSIC THREAD CUTTING



Со страницы: From page:
MJ / M
MF
UNJC / UNC / UNC(J)
UNJF / UNF / UNF(J)
UNEF / UN / UNS
G / Rp / Rc / W / SV
NPT / NPTF
PG / TR
EG M / EG UNC / EG UNF

N										
Нормальные материалы Normal materials										
60	62	60	64	64	72	72	74	60	74	74
125	124	125	125		124		131	131	131	
154	154	154	154				156	156	156	
176	176	176	176				178	178	178	
198	198						199	199		
204	205	205	205				206	206	206	
220										
222	222									
	226	226					227	227		



N.10	N.20	N.20V	N.20TN	N.20TC	N.50	N.50V	N.60	N.60V	N.60TN	N.60TC

	Vc (m/min) Guide Line					
	Ø 1 - 2.8 mm		Ø 2.8 - 26 mm		Ø 26 - 60 mm	
	Стандартный Standard	С покрытием Coated	Стандартный Standard	С покрытием Coated	Стандартный Standard	С покрытием Coated
11	10 - 15	10 - 20	10 - 15	25 - 35	5 - 10	
12	10 - 15	10 - 20	10 - 15	25 - 35	5 - 10	
13	8 - 12	10 - 20	8 - 12	16 - 24	10 - 15	
14	8 - 12	10 - 20	8 - 12	16 - 24	4 - 8	
15	2 - 4	4 - 10	3 - 5	6 - 12	2 - 4	3 - 5
16		2 - 4	3 - 5	3 - 5	2 - 4	3 - 5
17			2 - 4			
18						
21	4 - 10	10 - 15	10 - 15	20 - 30	5 - 10	
22	3 - 6	4 - 8	3 - 6	6 - 12		
23	3 - 6	4 - 8	3 - 6	6 - 12		
24		3 - 5		4 - 8		3 - 5
31	10 - 15	10 - 20	10 - 15	20 - 30	5 - 10	15 - 25
32	10 - 15	10 - 20	10 - 15	20 - 30	5 - 10	
41	2 - 4	4 - 8	4 - 8	4 - 8		
42	2 - 4	3 - 5	3 - 5	3 - 5		
51		3 - 5		6 - 12		
52			4 - 8	4 - 8		
53			2 - 4			
61	8 - 12		8 - 12	12 - 16	4 - 8	
62	6 - 12	6 - 12	20 - 30	30 - 40	15 - 25	25 - 35
63	10 - 20		16 - 24		8 - 12	
64	10 - 20		16 - 24		8 - 12	
71	10 - 15	10 - 15	10 - 15	20 - 40	5 - 10	
72	10 - 20	20 - 30	20 - 30	20 - 40	10 - 15	
73	10 - 15	10 - 20	10 - 15	20 - 30	5 - 10	
74	10 - 15	10 - 20	10 - 15	20 - 30	5 - 10	
81	10 - 20		20 - 30	30 - 50	10 - 15	
82	8 - 16	16 - 24	8 - 16	16 - 24	5 - 12	10 - 15
83		6 - 12		8 - 16		5 - 12
91	12 - 20		20 - 30			
92		12 - 16		12 - 16		
93		4 - 8		4 - 8		
94		12 - 20		16 - 24		

НАРЕЗАНИЕ РЕЗЬБЫ — CLASSIC THREAD CUTTING



Со страницы: From page:
MJ / M
MF
UNJC / UNC / UNC(J)
UNJF / UNF / UNF(J)
UNEF / UN / UNS
G / Rp / Rc / W / SV
NPT / NPTF
PG / TR
EG M / EG UNC / EG UNF

AERO								
SA Специальные сплавы Special alloys			TL Титановые. Titan. alloys		GG Чугун и алюминиевое литье Cast iron / Al casting			
47	47	46	100	47	102	102	102	
140	140	139	140	140				
49	49	48	165	49				
51	51	50		51				
					207			
228	228	229	232	228				



SA.20	SA.50	SA.90	TL.20VS	TL.51VS	GG.50NV	GG.50TC	GG.53TC

Vc (m/min) Guide Line					
Ø 1 - 2.8 mm		Ø 2.8 - 26 mm		Ø 26 - 60 mm	
Стандартный Standard	С покрытием Coated	Стандартный Standard	С покрытием Coated	Стандартный Standard	С покрытием Coated

11	10 - 15	10 - 20	10 - 15	25 - 35	5 - 10							11	
12	10 - 15	10 - 20	10 - 15	25 - 35	5 - 10							12	
13	8 - 12	10 - 20	8 - 12	16 - 24	10 - 15							13	
14	8 - 12	10 - 20	8 - 12	16 - 24	4 - 8							14	
15	2 - 4	4 - 10	3 - 5	6 - 12	2 - 4	3 - 5						15	
16		2 - 4	3 - 5	3 - 5	2 - 4	3 - 5						16	
17			2 - 4									17	
18												18	
21	4 - 10	10 - 15	10 - 15	20 - 30	5 - 10							21	
22	3 - 6	4 - 8	3 - 6	6 - 12								22	
23	3 - 6	4 - 8	3 - 6	6 - 12								23	
24		3 - 5		4 - 8		3 - 5						24	
31	10 - 15	10 - 20	10 - 15	20 - 30	5 - 10	15 - 25							31
32	10 - 15	10 - 20	10 - 15	20 - 30	5 - 10								32
41	2 - 4	4 - 8	4 - 8	4 - 8									41
42	2 - 4	3 - 5	3 - 5	3 - 5									42
51		3 - 5		6 - 12									51
52			4 - 8	4 - 8									52
53			2 - 4										53
61	8 - 12		8 - 12	12 - 16	4 - 8								61
62	6 - 12	6 - 12	20 - 30	30 - 40	15 - 25	25 - 35							62
63	10 - 20		16 - 24		8 - 12								63
64	10 - 20		16 - 24		8 - 12								64
71	10 - 15	10 - 15	10 - 15	20 - 40	5 - 10								71
72	10 - 20	20 - 30	20 - 30	20 - 40	10 - 15								72
73	10 - 15	10 - 20	10 - 15	20 - 30	5 - 10								73
74	10 - 15	10 - 20	10 - 15	20 - 30	5 - 10								74
81	10 - 20		20 - 30	30 - 50	10 - 15								81
82	8 - 16	16 - 24	8 - 16	16 - 24	5 - 12	10 - 15							82
83		6 - 12		8 - 16		5 - 12							83
91	12 - 20		20 - 30										91
92		12 - 16		12 - 16									92
93		4 - 8		4 - 8									93
94		12 - 20		16 - 24									94

A Оптимально с воздухом
Optimal with air

A Допустимо с воздухом
Suitable with air

CD Ограниченное применение
Limited

Указаны ориентировочные значения.
The indicated values are a guideline.

НАРЕЗАНИЕ РЕЗЬБЫ И СКОРОСТНОЕ НАРЕЗАНИЕ РЕЗЬБЫ С ЧПУ CLASSIC THREAD CUTTING AND RIGID TAPPING

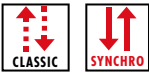

Нарезание резьбы Thread cutting

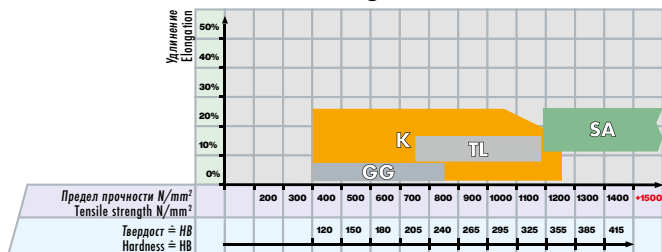

Со страницы:
From page:

MJ / M
MF
UNJC / UNC / UNC(J)
UNJF / UNF / UNF(J)
UNEF / UN / UNS
G / Rp / Rc / W / SV
NPT / NPTF
PG / TR
EG M / EG UNC / EG UNF

K Серия "K" для глубоких резьб Swarf breaker	
104	105
142	



Vc (m/min) Guide Line			
Ø 5 - 10.9 mm	Ø 11 - 18.9 mm	Ø 19 - 31.9 mm	Ø 32 - 42 mm
С покрытием Coated	С покрытием Coated	С покрытием Coated	С покрытием Coated

11	30 - 40	20 - 30	20 - 30	20 - 30
12	30 - 40	20 - 30	20 - 30	20 - 30
13	30 - 40	20 - 30	20 - 30	20 - 30
14	20 - 30	15 - 25	15 - 25	15 - 25
15	15 - 20	10 - 15	8 - 12	5 - 8
16	8 - 12	5 - 8	5 - 8	5 - 8
17				
18				
21				
22				
23				
24				
31	30 - 40	30 - 40	30 - 40	30 - 40
32	30 - 40	20 - 30	20 - 30	20 - 30
41				
42				
51				
52				
53				
61				
62	30 - 40	30 - 40	30 - 40	30 - 40
63	30 - 40	30 - 40	30 - 40	30 - 40
64	30 - 40	20 - 30	20 - 30	20 - 30
71				
72				
73				
74	30 - 40	30 - 40	30 - 40	30 - 40
81				
82				
83	30 - 40	30 - 40	30 - 40	30 - 40
91				
92				
93				
94				

K.137C	K.137S

E	E	11
E	E	12
E	E	13
E	E	14
E	E	15
E	E	16
		17
		18
		21
		22
		23
		24
E	E	31
E	E	32
		41
		42
		51
		52
		53
		61
E	E	62
E	E	63
E	E	64
		71
		72
		73
E	E	74
		81
		82
E	E	83
		91
		92
		93
		94

НАРЕЗАНИЕ РЕЗЬБЫ И СКОРОСТНОЕ НАРЕЗАНИЕ РЕЗЬБЫ С ЧПУ CLASSIC THREAD CUTTING AND RIGID TAPPING

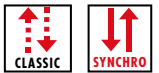

Нарезание резьбы и скоростное Thread cutting classic and rigid

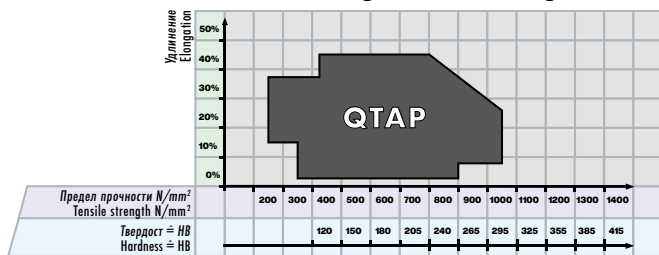

Со страницы:
From page:

MJ / M
MF
UNJC / UNC / UNC(J)
UNJF / UNF / UNF(J)
UNEF / UN / UNS
G / Rp / Rc / W / SV
NPT / NPTF
PG / TR
EG M / EG UNC / EG UNF

Q-TAP Универсальный метчик Allrounder

61	106	61	107
143	143	144	144
167	167	168	168
192	192	193	193
210	210	211	211



		Vc (m/min) Guide Line Ø 2.8 - 20 mm					
11	20 - 40	OE	OE	OE	OE	11	
12	20 - 40	OE	OE	OE	OE	12	
13	16 - 24	OE	OE	OE	OE	13	
14	16 - 24	OE	OE	OE	OE	14	
15	6 - 12	OE	OE	OE	OE	15	
16						16	
17						17	
18						18	
21	20 - 40	OE	OE	OE	OE	21	
22	6 - 12	OE	OE	OE	OE	22	
23	6 - 12	OE	OE	OE	OE	23	
24	4 - 8	OE	OE	OE	OE	24	
31	20 - 40	OE A	OE	OE A	OE	31	
32	20 - 40	OE	OE	OE	OE	32	
41						41	
42						42	
51	6 - 12	OE	OE	OE	OE	51	
52	4 - 8	OE	OE	OE	OE	52	
53						53	
61	12 - 16	OE	OE	OE	OE	61	
62	25 - 35	OE	OE	OE	OE	62	
63	20 - 40	OE	OE	OE	OE	63	
64	20 - 40	OE	OE	OE	OE	64	
71	20 - 40	OE	OE	OE	OE	71	
72	20 - 40	OE	OE	OE	OE	72	
73	20 - 40	OE	OE	OE	OE	73	
74	20 - 40	OE A	OE	OE A	OE	74	
81	20 - 40	OE A	OE	OE A	OE	81	
82	16 - 24	OE	OE	OE	OE	82	
83	8 - 16	OE A	OE	OE A	OE	83	
91	20 - 40	OE	OE	OE	OE	91	
92	12 - 16	OE	OE	OE	OE	92	
93						93	
94	12 - 16	OE	OE	OE	OE	94	



ТАБЛИЦА ПРИМЕНЕНИЯ — APPLICATION CHART

Скоростное нарезание резьбы Rigid Tapping

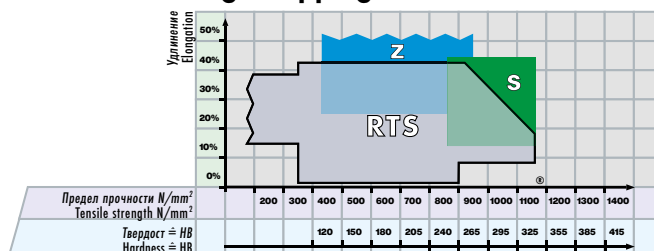

DC Классификация материалов

DC Material classification

Группы материалов Material groups	Обозначение материалов	Material designation	Твердость Hardness (HB)	Предел прочности Tensile strength Rm (N/mm ²)	Удлинение Elongation A (%)	
10 Стали Steels	11	Легко обрабатываемые стали	Free-cutting steels	< 200	< 700	< 10
	12	Структурные, цементуемые стали	Structural, cementation steels	< 200	< 700	< 30
	13	Углеродистые стали	Carbon steels	< 300	< 1000	< 20
	14	Легированные стали < 850 N/mm ²	Alloy steels < 850 N/mm ²	< 250	< 850	< 30
	15	Легированные стали закал./отп. > 850 - < 1150 N/mm ²	Alloy steels hard. / temp. > 850 - < 1150 N/mm ²	> 250	> 850	< 30
	16	Высокопрочные легированные стали ≤ 44 HRC	High tensile alloy steels ≤ 44 HRC	> 250	> 850	< 12
	17	Закалённые легированные стали > 44 - ≤ 54 HRC	Alloy steels tempered > 44 - ≤ 54 HRC	> 410	> 1400	< 2
	18	Закалённые легированные стали > 54 - ≤ 63 HRC	Alloy steels hardened > 54 - ≤ 63 HRC	> 560	> 1980	< 2
20 Нержавеющие стали Stainless steels	21	Легко обрабатываемые нержавеющие стали	Free machining stainless steels	< 250	< 850	< 25
	22	Аустенитные нержавеющие стали	Austenitic stainless steels	< 250	< 850	> 20
	23	Ферритные и мартенситные < 850 N/mm ²	Ferritic and martensitic < 850 N/mm ²	< 250	< 850	> 20
	24	Ферритные и мартенситные > 850 - < 1150 N/mm ²	Ferritic and martensitic > 850 - < 1150 N/mm ²	> 250	> 850	> 15
30 Чугун Cast iron	31	Чугун	Cast iron	< 250	< 850	< 10
	32	Высокопрочные и ковкий чугун	Spheroidal graphite + malleable cast iron	< 250	< 850	> 10
40 Титан Titanium	41	Чистый титан	Pure titanium	< 250	< 850	> 20
	42	Титановые сплавы	Titanium alloys	> 250	> 850	< 20
50 Никель Nickel	51	Никелевые сплавы 1 ≤ 850 N/mm ²	Nickel alloys 1 ≤ 850 N/mm ²	< 250	< 850	> 25
	52	Никелевые сплавы 2 > 850 - ≤ 1150 N/mm ²	Nickel alloys 2 > 850 - ≤ 1150 N/mm ²	> 250	> 850	< 25
	53	Никелевые сплавы 3 > 1150 - ≤ 1600 N/mm ²	Nickel alloys 3 > 1150 - ≤ 1600 N/mm ²	> 340	> 1150	< 20
60 Медь Copper	61	Медь чистая (электрохимическая)	Pure copper (electrolytic copper)	< 120	< 400	> 12
	62	Короткопружечная латунь, фосфористая бронза	Short chip brass, phosphor bronze, gun metal	< 200	< 700	< 12
	63	Длиннопружечная латунь	Long chip brass	< 200	< 700	> 12
	64	Безсвинцовая латунь	Lead free brass	< 220	< 700	> 15
70 Алюминий Магний Aluminium Magnesium	71	Алюминий чистый	Al unalloyed	< 100	< 350	> 15
	72	Алюминиевые сплавы Si < 1.5 %	Al alloyed Si < 1.5 %	< 150	< 500	> 15
	73	Алюминиевые сплавы Si > 1.5 % - < 10 %	Al alloyed Si > 1.5 % - < 10 %	< 120	< 400	< 15
	74	Алюминиевые сплавы Si > 10 %, магниевые сплавы	Al alloyed Si > 10 %, Mg-alloys	< 120	< 400	< 10
80 Пластики Plastic compounds	81	Термопластики	Thermoplastics	-	-	-
	82	Дюропластики	Duroplastics	-	-	-
	83	Пластики армированные стекловолокном	Glass fibre reinforced plastics	-	-	-
90 Драгоценные металлы Precious metals	91	Желтое золото	Yellow gold	-	-	-
	92	Красное золото	Red gold	-	-	-
	93	Белое золото	White gold	-	-	-
	94	Серебро	Silver	-	-	-

ТАБЛИЦА ПРИМЕНЕНИЯ — APPLICATION CHART

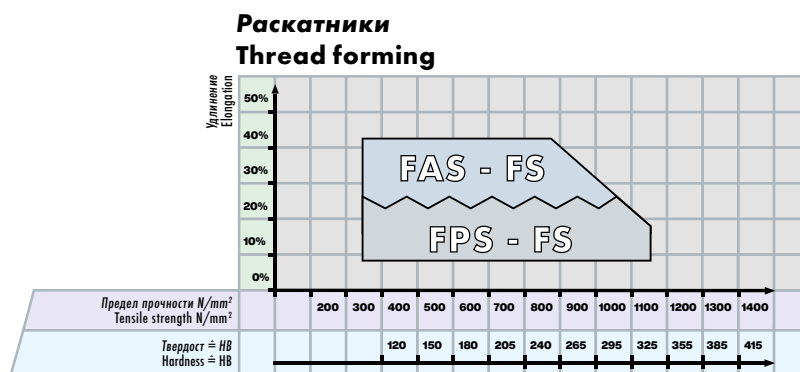

DC Классификация материалов

DC Material classification

Группы материалов Material groups	Обозначение материалов	Material designation	Твердость Hardness (HB)	Предел прочности Tensile strength Rm (N/mm ²)	Удлинение Elongation A (%)	
10 Стали Steels	11	Легко обрабатываемые стали	Free-cutting steels	< 200	< 700	< 10
	12	Структурные, цементуемые стали	Structural, cementation steels	< 200	< 700	< 30
	13	Углеродистые стали	Carbon steels	< 300	< 1000	< 20
	14	Легированные стали < 850 N/mm ²	Alloy steels < 850 N/mm ²	< 250	< 850	< 30
	15	Легированные стали закал./отп. > 850 - < 1150 N/mm ²	Alloy steels hard. / temp. > 850 - < 1150 N/mm ²	> 250	> 850	< 30
	16	Высокопрочные легированные стали ≤ 44 HRC	High tensile alloy steels ≤ 44 HRC	> 250	> 850	< 12
	17	Закалённые легированные стали > 44 - ≤ 54 HRC	Alloy steels tempered > 44 - ≤ 54 HRC	> 410	> 1400	< 2
	18	Закалённые легированные стали > 54 - ≤ 63 HRC	Alloy steels hardened > 54 - ≤ 63 HRC	> 560	> 1980	< 2
20 Нержавеющие стали Stainless steels	21	Легко обрабатываемые нержавеющие стали	Free machining stainless steels	< 250	< 850	< 25
	22	Аустенитные нержавеющие стали	Austenitic stainless steels	< 250	< 850	> 20
	23	Ферритные и мартенситные < 850 N/mm ²	Ferritic and martensitic < 850 N/mm ²	< 250	< 850	> 20
	24	Ферритные и мартенситные > 850 - < 1150 N/mm ²	Ferritic and martensitic > 850 - < 1150 N/mm ²	> 250	> 850	> 15
30 Чугун Cast iron	31	Чугун	Cast iron	< 250	< 850	< 10
	32	Высокопрочные и ковкий чугун	Spheroidal graphite + malleable cast iron	< 250	< 850	> 10
40 Титан Titanium	41	Чистый титан	Pure titanium	< 250	< 850	> 20
	42	Титановые сплавы	Titanium alloys	> 250	> 850	< 20
50 Никель Nickel	51	Никелевые сплавы 1 ≤ 850 N/mm ²	Nickel alloys 1 ≤ 850 N/mm ²	< 250	< 850	> 25
	52	Никелевые сплавы 2 > 850 - ≤ 1150 N/mm ²	Nickel alloys 2 > 850 - ≤ 1150 N/mm ²	> 250	> 850	< 25
	53	Никелевые сплавы 3 > 1150 - ≤ 1600 N/mm ²	Nickel alloys 3 > 1150 - ≤ 1600 N/mm ²	> 340	> 1150	< 20
60 Медь Copper	61	Медь чистая (электрохимическая)	Pure copper (electrolytic copper)	< 120	< 400	> 12
	62	Короткостружечная латунь, фосфористая бронза	Short chip brass, phosphor bronze, gun metal	< 200	< 700	< 12
	63	Длинностружечная латунь	Long chip brass	< 200	< 700	> 12
	64	Безсвинцовая латунь	Lead free brass	< 220	< 700	> 15
70 Алюминий Магний Aluminium Magnesium	71	Алюминий чистый	Al unalloyed	< 100	< 350	> 15
	72	Алюминиевые сплавы Si < 1.5 %	Al alloyed Si < 1.5 %	< 150	< 500	> 15
	73	Алюминиевые сплавы Si > 1.5 % - < 10 %	Al alloyed Si > 1.5 % - < 10 %	< 120	< 400	< 15
	74	Алюминиевые сплавы Si > 10 %, магниевые сплавы	Al alloyed Si > 10 %, Mg-alloys	< 120	< 400	< 10
80 Пластики Plastic compounds	81	Термопластики	Thermoplastics	-	-	-
	82	Дюропластики	Duroplastics	-	-	-
	83	Пластики армированные стекловолокном	Glass fibre reinforced plastics	-	-	-
90 Драгоценные металлы Precious metals	91	Желтое золото	Yellow gold	-	-	-
	92	Красное золото	Red gold	-	-	-
	93	Белое золото	White gold	-	-	-
	94	Серебро	Silver	-	-	-

РАСКАТНИКИ — THREAD FORMING



Со страницы: From page:	FS		FPS					FAS		
M	254	255	256	256	256	256	258	259	259	260
MF							262		262	
UNC	263						263		263	
UNF	264						264		264	
G							265		265	



NEW **NEW**

V_c
(m/min)
Guide Line
Ø 1 - 2.8 mm Ø 2.8 - 20 mm

	V _c (m/min) Guide Line		FS		FPS					FAS			
	Ø 1 - 2.8 mm	Ø 2.8 - 20 mm	FS.80VS	FS.80DL	FPS.80DL	FPS.81DL	FPS.80VS	FPS.81VS	FPS.84VS	FAS.80VS	FAS.81VS	FAS.84VS	
11	12 - 20	20 - 40	○ E				○ E	○ E	○ E				11
12	12 - 20	20 - 40	○ E				○ E	○ E	○ E				12
13	12 - 20	20 - 30	○ E				○ E	○ E	○ E				13
14	12 - 20	20 - 30	○ E				○ E	○ E	○ E				14
15	6 - 12	10 - 15	○					○	○				15
16													16
17													17
18													18
21	12 - 20	10 - 20	○ E	○ E						○ E	○ E	○ E	21
22	6 - 12	10 - 15	○	○ E						○ E	○ E	○ E	22
23	6 - 12	6 - 12	○	○ E						○	○ E	○ E	23
24	6 - 12	6 - 12		○						○	○ E	○ E	24
31													31
32													32
41	12 - 20	10 - 20		○							○	○	41
42													42
51	6 - 12	10 - 15		○							○ E	○ E	51
52													52
53													53
61	12 - 20	10 - 20		○ E						○	○ E	○ E	61
62													62
63	12 - 20	20 - 30		○ E	○ E	○ E							63
64	12 - 20	20 - 30		○ E	○ E	○ E							64
71	12 - 20	20 - 40		○ E	○ E	○ E							71
72	12 - 20	20 - 40		○ E	○ E	○ E							72
73	12 - 20	20 - 40		○ E	○ E	○ E							73
74													74
81													81
82													82
83													83
91	12 - 20	20 - 40		○ E	○	○ E							91
92	12 - 20	20 - 40		○ E	○ E	○ E							92
93	12 - 20	20 - 40		○	○	○							93
94	12 - 20	20 - 40		○ E	○ E	○ E							94

**МАШИННЫЕ МЕТЧИКИ NANO
THREAD TAPS NANO**

DC Классификация материалов

DC Material classification

Группы материалов Material groups	Обозначение материалов	Material designation	Твердость Hardness (HV)	Предел прочности Tensile strength Rm (N/mm ²)	Удлинение Elongation A (%)	
10 Стали Steels	11	Легко обрабатываемые стали	Free-cutting steels	< 200	< 700	< 10
	12	Структурные, цементируемые стали	Structural, cementation steels	< 200	< 700	< 30
	13	Углеродистые стали	Carbon steels	< 300	< 1000	< 20
	14	Легированные стали < 850 N/mm ²	Alloy steels < 850 N/mm ²	< 250	< 850	< 30
	15	Легированные стали закал./отп. > 850 - < 1150 N/mm ²	Alloy steels hard. / temp. > 850 - < 1150 N/mm ²	> 250	> 850	< 30
	16	Высокопрочные легированные стали ≤ 44 HRC	High tensile alloy steels ≤ 44 HRC	> 250	> 850	< 12
	17	Закалённые легированные стали > 44 - ≤ 54 HRC	Alloy steels tempered > 44 - ≤ 54 HRC	> 410	> 1400	< 2
	18	Закалённые легированные стали > 54 - ≤ 63 HRC	Alloy steels hardened > 54 - ≤ 63 HRC	> 560	> 1980	< 2
20 Нержавеющие стали Stainless steels	21	Легко обрабатываемые нержавеющие стали	Free machining stainless steels	< 250	< 850	< 25
	22	Аустенитные нержавеющие стали	Austenitic stainless steels	< 250	< 850	> 20
	23	Ферритные и мартенситные < 850 N/mm ²	Ferritic and martensitic < 850 N/mm ²	< 250	< 850	> 20
	24	Ферритные и мартенситные > 850 - < 1150 N/mm ²	Ferritic and martensitic > 850 - < 1150 N/mm ²	> 250	> 850	> 15
30 Чугун Cast iron	31	Чугун	Cast iron	< 250	< 850	< 10
	32	Высокопрочные и ковкий чугун	Spheroidal graphite + malleable cast iron	< 250	< 850	> 10
40 Титан Titanium	41	Чистый титан	Pure titanium	< 250	< 850	> 20
	42	Титановые сплавы	Titanium alloys	> 250	> 850	< 20
50 Никель Nickel	51	Никелевые сплавы 1 ≤ 850 N/mm ²	Nickel alloys 1 ≤ 850 N/mm ²	< 250	< 850	> 25
	52	Никелевые сплавы 2 > 850 - ≤ 1150 N/mm ²	Nickel alloys 2 > 850 - ≤ 1150 N/mm ²	> 250	> 850	< 25
	53	Никелевые сплавы 3 > 1150 - ≤ 1600 N/mm ²	Nickel alloys 3 > 1150 - ≤ 1600 N/mm ²	> 340	> 1150	< 20
60 Медь Copper	61	Медь чистая (электрохимическая)	Pure copper (electrolytic copper)	< 120	< 400	> 12
	62	Короткостружечная латунь, фосфористая бронза	Short chip brass, phosphor bronze, gun metal	< 200	< 700	< 12
	63	Длинностружечная латунь	Long chip brass	< 200	< 700	> 12
	64	безсвинцовая латунь	Lead free brass	< 220	< 700	> 15
70 Алюминий Магний Aluminium Magnesium	71	Алюминий чистый	Al unalloyed	< 100	< 350	> 15
	72	Алюминиевые сплавы Si < 1.5 %	Al alloyed Si < 1.5 %	< 150	< 500	> 15
	73	Алюминиевые сплавы Si > 1.5 % - < 10 %	Al alloyed Si > 1.5 % - < 10 %	< 120	< 400	< 15
	74	Алюминиевые сплавы Si > 10 %, магниевые сплавы	Al alloyed Si > 10 %, Mg-alloys	< 120	< 400	< 10
80 Пластики Plastic compounds	81	Термопластики	Thermoplastics	-	-	-
	82	Дюропластики	Duroplastics	-	-	-
	83	Пластики армированные стекловолокном	Glass fibre reinforced plastics	-	-	-
90 Драгоценные металлы Precious metals	91	Желтое золото	Yellow gold	-	-	-
	92	Красное золото	Red gold	-	-	-
	93	Белое золото	White gold	-	-	-
	94	Серебро	Silver	-	-	-

**МАШИННЫЕ РАСКАТНИКИ NANO
THREAD FORMERS NANO**

DC Классификация материалов

DC Material classification

Группы материалов Material groups	Обозначение материалов	Material designation	Твердость Hardness (HB)	Предел прочности Tensile strength Rm (N/mm ²)	Удлинение Elongation A (%)	
10 Стали Steels	11	Легко обрабатываемые стали	Free-cutting steels	< 200	< 700	< 10
	12	Структурные, цементуемые стали	Structural, cementation steels	< 200	< 700	< 30
	13	Углеродистые стали	Carbon steels	< 300	< 1000	< 20
	14	Легированные стали < 850 N/mm ²	Alloy steels < 850 N/mm ²	< 250	< 850	< 30
	15	Легированные стали закал./отп. > 850 - < 1150 N/mm ²	Alloy steels hard. / temp. > 850 - < 1150 N/mm ²	> 250	> 850	< 30
	16	Высокопрочные легированные стали ≤ 44 HRC	High tensile alloy steels ≤ 44 HRC	> 250	> 850	< 12
	17	Закалённые легированные стали > 44 - ≤ 54 HRC	Alloy steels tempered > 44 - ≤ 54 HRC	> 410	> 1400	< 2
	18	Закалённые легированные стали > 54 - ≤ 63 HRC	Alloy steels hardened > 54 - ≤ 63 HRC	> 560	> 1980	< 2
20 Нержавеющие стали Stainless steels	21	Легко обрабатываемые нержавеющие стали	Free machining stainless steels	< 250	< 850	< 25
	22	Аустенитные нержавеющие стали	Austenitic stainless steels	< 250	< 850	> 20
	23	Ферритные и мартенситные < 850 N/mm ²	Ferritic and martensitic < 850 N/mm ²	< 250	< 850	> 20
	24	Ферритные и мартенситные > 850 - < 1150 N/mm ²	Ferritic and martensitic > 850 - < 1150 N/mm ²	> 250	> 850	> 15
30 Чугун Cast iron	31	Чугун	Cast iron	< 250	< 850	< 10
	32	Высокопрочные и ковкий чугун	Spheroidal graphite + malleable cast iron	< 250	< 850	> 10
40 Титан Titanium	41	Чистый титан	Pure titanium	< 250	< 850	> 20
	42	Титановые сплавы	Titanium alloys	> 250	> 850	< 20
50 Никель Nickel	51	Никелевые сплавы 1 ≤ 850 N/mm ²	Nickel alloys 1 ≤ 850 N/mm ²	< 250	< 850	> 25
	52	Никелевые сплавы 2 > 850 - ≤ 1150 N/mm ²	Nickel alloys 2 > 850 - ≤ 1150 N/mm ²	> 250	> 850	< 25
	53	Никелевые сплавы 3 > 1150 - ≤ 1600 N/mm ²	Nickel alloys 3 > 1150 - ≤ 1600 N/mm ²	> 340	> 1150	< 20
60 Медь Copper	61	Медь чистая (электротехническая)	Pure copper (electrolytic copper)	< 120	< 400	> 12
	62	Короткостружечная латунь, фосфористая бронза	Short chip brass, phosphor bronze, gun metal	< 200	< 700	< 12
	63	Длинностружечная латунь	Long chip brass	< 200	< 700	> 12
	64	безсвинцовая латунь	Lead free brass	< 220	< 700	> 15
70 Алюминий Магний Aluminium Magnesium	71	Алюминий чистый	Al unalloyed	< 100	< 350	> 15
	72	Алюминиевые сплавы Si < 1.5 %	Al alloyed Si < 1.5 %	< 150	< 500	> 15
	73	Алюминиевые сплавы Si > 1.5 % - < 10 %	Al alloyed Si > 1.5 % - < 10 %	< 120	< 400	< 15
	74	Алюминиевые сплавы Si > 10 %, магниевые сплавы	Al alloyed Si > 10 %, Mg-alloys	< 120	< 400	< 10
80 Пластики Plastic compounds	81	Термопластики	Thermoplastics	-	-	-
	82	Дюропластики	Duroplastics	-	-	-
	83	Пластики армированные стекловолокном	Glass fibre reinforced plastics	-	-	-
90 Драгоценные металлы Precious metals	91	Желтое золото	Yellow gold	-	-	-
	92	Красное золото	Red gold	-	-	-
	93	Белое золото	White gold	-	-	-
	94	Серебро	Silver	-	-	-

МАШИННЫЕ РАСКАТНИКИ NANO — THREAD FORMERS NANO



Со страницы: From page:
M
MF
UNC
UNF
S
SF
SL

FA Нормальные материалы Normal materials		CFA Цветные материалы Non-ferrous materials	
363	363	370	370
364	364		
365	365	371	371
366	366	372	372
367	367	373	373
368	368		
369	369		
FA80VS	FA83VS	CFA80VS	CFA83VS

	Vc (m/min) Guide Line				
	Ø 0.3 - 1.4 mm Стандартный Coated	Ø 1.4 - 2.8 mm С покрытием Coated			
11	4 - 10	12 - 20			11
12	4 - 10	12 - 20			12
13	4 - 10	12 - 20			13
14	4 - 10	12 - 20			14
15	3 - 6	6 - 12			15
16					16
17					17
18					18
21	4 - 10	12 - 20			21
22	3 - 6	6 - 12			22
23	3 - 6	6 - 12			23
24	3 - 6	6 - 12			24
31					31
32					32
41					41
42					42
51	3 - 6	6 - 12			51
52					52
53					53
61	4 - 10	12 - 20			61
62	4 - 10	12 - 20			62
63	4 - 10	12 - 20			63
64	4 - 10	12 - 20			64
71	4 - 10	12 - 20			71
72	4 - 10	12 - 20			72
73	4 - 10	12 - 20			73
74					74
81					81
82					82
83					83
91	4 - 10	12 - 20			91
92	4 - 10	12 - 20			92
93	4 - 10	12 - 20			93
94	4 - 10	12 - 20			94

КОНСТРУКТИВНОЕ ИСПОЛНЕНИЕ МЕТЧИКОВ CONSTRUCTIONAL DESIGN OF THREADING TAPS

		Конструкция в соответствии с ISO/DIN - Общие размеры	Design according to ISO / DIN General dimensions
ISO 529 DIN 5157 (G)	N1110-. / N1210-. N210-. (G)	Ручные метчики с увеличением среднего диаметра	Hand taps with stepped pitch diameter
ISO 529 DIN 5157 (G)	N1110-3 / N1210-3 N1120-4 / N1220-4 N1160-3 / N1260-3 N210-3 / N220-4 (G)	Короткие машинные метчики	Short machine taps
DIN 352	NP110-S NP210-S	Ручные метчики с увеличением среднего диаметра Короткие машинные метчики	Hand taps with stepped pitch diameter, taper tap -1 with guiding pilot
DIN 371	N3.; W3.; Z3.; H3.; S3.; SA3.; TL3.; GG3.; K3.; Q3.; RTS3.;	Машинные метчики с усиленным хвостовиком по DIN	Machine taps with reinforced DIN shank
DIN 376 / DIN 374 / DIN 5156 (G)	N4.; W4.; Z4.; H4.; S4.; SA4.; TL4.; GG4.; K4.; Q4.; RTS4.;	Машинные метчики с утонченным хвостовиком по DIN	Machine taps with reduced DIN shank

		Конструкция в соответствии со стандартами DC Общие размеры	Design according to DC standards General dimensions
DC	K613	Удлиненные машинные метчики с длинными канавками и утонченным хвостовиком по DIN	Extra-long machine taps with long flutes and reduced DIN shank
DC / DIN 371	N5.; GG5.; RTS5.;	Удлиненные машинные метчики с усиленным хвостовиком по DIN Общая длина согласно нормам DC, размеры хвостовика по DIN 371	Extra-long machine taps with reinforced DIN shank Overall length as per norm DC, shank dimensions as per DIN 371
DC / DIN 376	N6.; GG6.; RTS6.; K6.;	Удлиненные машинные метчики с утонченным хвостовиком по DIN Общая длина согласно нормам DC, размеры хвостовика по DIN 376	Extra-long machine taps with reduced DIN shank Overall length as per norm DC, shank dimensions as per DIN 376
DC	N470V-	Корончатые метчики	Crown taps
DC	N5951 / N5952	Комбинированные сверла/ метчики	Combination drill/tap

КОНСТРУКТИВНОЕ ИСПОЛНЕНИЕ ОТ МАШИННЫЕ РАСКАТНИКИ CONSTRUCTIONAL DESIGN OF THREAD FORMING TAPS

		Конструкция в соответствии с DIN - Общие размеры	Design according to DIN General dimensions
~ DIN 2174 (M - MF) ~ DIN 2184-1 (UNC - UNF)	FS3.; FAS3.; FPS3.;	Машинные раскатники с усиленным хвостовиком по DIN	Machine thread formers with reinforced DIN shank
~ DIN 2174 (M - MF) ~ DIN 2184-1 (UNC - UNF) ~ DIN 2189 (G)	FAS4.; FPS4.;	Машинные раскатники с утонченным хвостовиком по DIN	Machine thread formers with reduced DIN shank

		Конструкция в соответствии со стандартами DC Общие размеры	Design according to DC standards General dimensions
DC / ~ DIN 2174	FAS5.; FPS5.;	Удлиненные машинные раскатники с усиленным хвостовиком по DIN Общая длина согласно нормам DC, размеры хвостовика схожи с DIN 2174	Extra-long machine thread formers with reinforced DIN shank Overall length as per norm DC, shank dimensions similar to DIN 2174
DC / ~ DIN 2174	FAS6.; FPS6.;	Удлиненные машинные раскатники с утонченным хвостовиком по DIN Общая длина согласно нормам DC, размеры хвостовика схожи с DIN 2174	Extra-long machine thread formers with reduced DIN shank Overall length as per norm DC, shank dimensions similar to DIN 2174

ТАБЛИЦА ТВЕРДОСТИ — HARDNESS CHART

HRC Твердость Rockwell Hardness Rockwell	HB Твердость Brinell Hardness Brinell	HV Твердость Vickers Hardness Vickers	N/mm² Мпа Предел прочности Tensile strength
25	253	266	854
26	259	273	873
27	265	279	897
28	272	286	919
29	279	294	944
30	287	302	970
31	295	310	995
32	303	318	1024
33	311	327	1052
34	320	336	1082
35	328	345	1111
36	337	355	1139
37	346	364	1168
38	354	373	1198
39	363	382	1227
40	373	392	1262
41	382	402	1296
42	392	412	1327
43	402	423	1362
44	413	434	1401
45	424	446	1442
46	436	459	1481
47	448	471	1524
48	460	484	1572
49	474	499	1625
50	488	513	1675
51	502	528	1733
52	518	545	1793
53	532	560	1845
54	549	578	1912
55	566	596	1979
56	585	615	2050
57	603	634	2121
58	621	654	2200
59		675	
60		698	
61		720	
62		746	
63		773	

Переводная таблица для значений твердости, выдержка из ISO EN 18265; 2003 / бывший DIN 50150. Значения округлённые.
Conversion chart for hardness values, extract from ISO EN 18265; 2003 / formerly DIN 50150. Rounded values.

ДЮЙМЫ-ММ — INCHES-MM

Ø" d ₁	Ø mm	TPI UN											W(BSW)	BSF	G (BSP) Rp	Ø mm	
		UNC	UNF	UNEF	4	6	8	12	16	20	28	32					
0 1/16"	1.52 1.59		80											48		28	7.72
1 2 3/32"	1.85 2.18 2.38	64 56	72 64														
3 4 5 1/8"	2.51 2.84 3.17 3.17	48 40 40	56 48 44											40		28	9.72
6 5/32"	3.50	32	40											32			
8 3/16"	3.96 4.16 4.76	32	36											24	32		
10 12	4.82 5.48	24 24	32 28	32													
7/32"	5.55												24	28		19	13.15
1/4"	6.35	20	28	32									20	26	26		
9/32"	7.14																
5/16"	7.93	18	24	32					20	28							
3/8"	9.52	16	24	32					20	28			16	20		19	16.66
7/16"	11.11	14	20	28					16				32	14	18		
1/2"	12.70	13	20	28					16				32	12	16	14	20.95
9/16"	14.28	12	18	24					16	20	28		32	12	16		
5/8"	15.87	11	18	24				12	16	20	28		32	11	14	14	22.91
11/16"	17.46			24				12	16	20	28		32		14		
3/4"	19.05	10	16	20				12			28	32	10	12	14	14	26.44
13/16"	20.64			20				12	16		28	32		12	11		
7/8"	22.22	9	14	20				12	16		28	32	9	11	14	14	30.20
15/16"	23.81			20				12	16		28	32					
1"	25.40	8	12	20				16			28	32	8	10	11	11	33.24
1 1/16"	26.99			18			8	12	16	20	28						
1 1/8"	28.57	7	12	18			8		16	20	28		7	9	11	11	37.89
1 3/16"	30.16			18			8	12	16	20	28						
1 1/4"	31.75	7	12	18			8		16	20	28		7	9	11	11	41.91
1 5/16"	33.34			18			8	12	16	20	28						
1 3/8"	34.92	6	12	18			8		16	20	28		6	8	11	11	44.32
1 7/16"	36.51			18			8	12	16	20	28						
1 1/2"	38.10	6	12	18		6	8	12	16	20	28		6	8	11	11	47.80
1 9/16"	39.69			18		6	8	12	16	20							
1 5/8"	41.28			18		6	8	12	16	20			5	8			
1 11/16"	42.86			18													
1 3/4"	44.45	5				6	8	12	16	20			5	7	11	11	53.74
1 13/16"	46.04					6	8	12	16	20							
1 7/8"	47.63					6	8	12	16	20			4 1/2				
1 15/16"	49.21					6	8	12	16	20							
2"	50.80	4 1/2											4 1/2	7	11	11	59.61
2 1/8"	53.97					6	8	12	16	20							
2 1/4"	57.15	4 1/2				6	8	12	16	20			4	6	11	11	65.71
2 3/8"	60.32					6	8	12	16	20							
2 1/2"	63.50	4				6	8	12	16	20			4	6	11	11	75.18
2 5/8"	66.67				4	6	8	12	16	20							
2 3/4"	69.85	4				6	8	12	16	20			3 1/2	6	11	11	81.53
2 7/8"	73.02				4	6	8	12	16	20							
3"	76.20	4				6	8	12	16	20			3 1/2	5	11	11	87.88
3 1/8"	79.37				4	6	8	12	16								
3 1/4"	82.55	4				6	8	12	16				3 1/4	5	11	11	93.98
3 3/8"	85.72				4	6	8	12	16								
3 1/2"	88.90	4				6	8	12	16				3 1/4	4 1/2	11	11	100.33
3 5/8"	92.07				4	6	8	12	16								
3 3/4"	95.25	4				6	8	12	16				3	4 1/2	11	11	106.68
3 7/8"	98.42				4	6	8	12	16								
4"	101.60	4				6	8	12	16				3	4 1/2	11	11	113.03

ПЕРЕВОДНАЯ ТАБЛИЦА – CONVERSION TABLE

		Vc m/min															
		1	2	3	4	5	6	8	10	12	15	20	25	30	40	50	60
		min ⁻¹															
Ø d ₁	1	318	637	955	1273	1592	1910	2546	3183	3820	4775	6366	7958	9549	12732	15915	19099
	2	159	318	477	637	796	955	1273	1592	1910	2387	3183	3979	4775	6366	7958	9549
	3	106	212	318	424	531	637	849	1061	1273	1592	2122	2653	3183	4244	5305	6366
	4	80	159	239	318	398	477	637	796	955	1194	1592	1989	2387	3183	3979	4775
	5	64	127	191	255	318	382	509	637	764	955	1273	1592	1910	2546	3183	3820
	6	53	106	159	212	265	318	424	531	637	796	1061	1326	1592	2122	2653	3183
	8	40	80	119	159	199	239	318	398	477	597	796	995	1194	1592	1989	2387
	10	32	64	95	127	159	191	255	318	382	477	637	796	955	1273	1592	1910
	12	27	53	80	106	133	159	212	265	318	398	531	663	796	1061	1326	1592
	14	23	45	68	91	114	136	182	227	273	341	455	568	682	909	1137	1364
	16	20	40	60	80	99	119	159	199	239	298	398	497	597	796	995	1194
	18	18	35	53	71	88	106	141	177	212	265	354	442	531	707	884	1061
	20	16	32	48	64	80	95	127	159	191	239	318	398	477	637	796	955
	25	13	25	38	51	64	76	102	127	153	191	255	318	382	509	637	764
	30	11	21	32	42	53	64	85	106	127	159	212	265	318	424	531	637
	35	9	18	27	36	45	55	73	91	109	136	182	227	273	364	455	546
40	8	16	24	32	40	48	64	80	95	119	159	199	239	318	398	477	
45	7	14	21	28	35	42	57	71	85	106	141	177	212	283	354	424	
50	6	13	19	25	32	38	51	64	76	95	127	159	191	255	318	382	

ОТВЕРСТИЯ ПОД РЕЗЬБЫ — CORE HOLES

M ISO DIN 14 4H5H (рекомендуемые / recommended)

Ø	P	Внутренний диаметр гайки Core Ø nut		Ø guide line
		Ø mini	Ø maxi	
d ₁	mm			
0.3	0.080	0.223	0.240	0.23
0.35	0.090	0.264	0.286	0.28
0.4	0.100	0.304	0.330	0.32
0.5	0.125	0.380	0.415	0.41
0.6	0.150	0.456	0.502	0.50
0.7	0.175	0.532	0.585	0.58
0.8	0.200	0.608	0.665	0.66
0.9	0.225	0.684	0.745	0.74



MF DIN 13, ISO 261, *4H / 6H

Ø	P	Внутренний диаметр гайки Core Ø nut		Ø guide line
		Ø mini	Ø maxi	
d ₁	mm			
*1.4	0.20	1.183	1.221	1.20
*1.6	0.20	1.383	1.421	1.40
*1.8	0.20	1.583	1.621	1.60
*2	0.20	1.783	1.821	1.80
*2	0.25	1.729	1.774	1.75
*2.2	0.20	1.983	2.021	2.00
*2.2	0.25	1.929	1.974	1.95
*2.3	0.20	2.083	2.121	2.10
*2.3	0.25	2.029	2.074	2.05
*2.5	0.20	2.283	2.321	2.30
*2.5	0.25	2.229	2.274	2.25
2.5	0.35	2.121	2.221	2.15
2.6	0.35	2.221	2.321	2.25
3	0.35	2.621	2.721	2.65
3.5	0.35	3.121	3.221	3.15
4	0.50	3.459	3.599	3.50
4.5	0.50	3.959	4.099	4.00
5	0.50	4.459	4.599	4.50
5.5	0.50	4.959	5.099	5.00
6	0.75	5.188	5.378	5.25
7	0.75	6.188	6.378	6.25
8	0.75	7.188	7.378	7.25
8	1.00	6.917	7.153	7.00
9	0.75	8.188	8.378	8.25
9	1.00	7.917	8.153	8.00
10	0.75	9.188	9.378	9.25
10	1.00	8.917	9.153	9.00
10	1.25	8.647	8.912	8.80
11	0.75	10.188	10.378	10.25
11	1.00	9.917	10.153	10.00
12	1.00	10.917	11.153	11.00
12	1.25	10.647	10.912	10.80
12	1.50	10.376	10.676	10.50
14	1.00	12.917	13.153	13.00
14	1.25	12.647	12.912	12.80
14	1.50	12.376	12.676	12.50
15	1.00	13.917	14.153	14.00
15	1.50	13.376	13.676	13.50
16	1.00	14.917	15.153	15.00
16	1.50	14.376	14.676	14.50
17	1.00	15.917	16.153	16.00
17	1.50	15.376	15.676	15.50
18	1.00	16.917	17.153	17.00
18	1.50	16.376	16.676	16.50
18	2.00	15.835	16.210	16.00
20	1.00	18.917	19.153	19.00
20	1.50	18.376	18.676	18.50
20	2.00	17.835	18.210	18.00
22	1.00	20.917	21.153	21.00
22	1.50	20.376	20.676	20.50
22	2.00	19.835	20.210	20.00
24	1.00	22.917	23.153	23.00
24	1.50	22.376	22.676	22.50
24	2.00	21.835	22.210	22.00
25	1.00	23.917	24.153	24.00
25	1.50	23.376	23.676	23.50
25	2.00	22.835	23.210	23.00



M DIN 13, ISO 261, *5H / 6H

Ø	P	Внутренний диаметр гайки Core Ø nut		Ø guide line
		Ø mini	Ø maxi	
d ₁	mm			
*1	0.25	0.729	0.785	0.75
*1.1	0.25	0.829	0.885	0.85
*1.2	0.25	0.929	0.985	0.95
*1.4	0.30	1.075	1.142	1.10
1.6	0.35	1.221	1.321	1.25
1.7	0.35	1.321	1.421	1.35
1.8	0.35	1.421	1.521	1.45
2	0.40	1.567	1.679	1.60
2.2	0.45	1.713	1.838	1.75
2.3	0.40	1.867	1.979	1.90
2.5	0.45	2.013	2.138	2.05
2.6	0.45	2.113	2.238	2.15
3	0.50	2.459	2.599	2.50
3.5	0.60	2.850	3.010	2.90
4	0.70	3.242	3.422	3.30
4.5	0.75	3.688	3.878	3.75
5	0.80	4.134	4.334	4.20
6	1.00	4.917	5.153	5.00
7	1.00	5.917	6.153	6.00
8	1.25	6.647	6.912	6.80
9	1.25	7.647	7.912	7.80
10	1.50	8.376	8.676	8.50
11	1.50	9.376	9.676	9.50
12	1.75	10.106	10.441	10.20
14	2.00	11.835	12.210	12.00
16	2.00	13.835	14.210	14.00
18	2.50	15.294	15.744	15.50
20	2.50	17.294	17.744	17.50
22	2.50	19.294	19.744	19.50
24	3.00	20.752	21.252	21.00
27	3.00	23.752	24.252	24.00
30	3.50	26.211	26.771	26.50
33	3.50	29.211	29.771	29.50
36	4.00	31.670	32.270	32.00
39	4.00	34.670	35.270	35.00
42	4.50	37.129	37.799	37.50
45	4.50	40.129	40.799	40.50
48	5.00	42.587	43.297	43.00
52	5.00	46.587	47.297	47.00
56	5.50	50.046	50.796	50.50



ОТВЕРСТИЯ ПОД РЕЗЬБЫ — CORE HOLES

MF DIN 13, ISO 261, 6H

Ø	P	Внутренний диаметр гайки Core Ø nut		Ø guide line
		Ø mini	Ø maxi	
d ₁	mm			
27	1.50	25.376	25.676	25.50
27	2.00	24.835	25.210	25.00
28	1.00	26.917	27.153	27.00
28	1.50	26.376	26.676	26.50
28	2.00	25.835	26.210	26.00
30	1.00	28.917	29.153	29.00
30	1.50	28.376	28.676	28.50
30	2.00	27.835	28.210	28.00
32	1.50	30.376	30.676	30.50
32	2.00	29.835	30.210	30.00
33	1.50	31.376	31.676	31.50
33	2.00	30.835	31.210	31.00
35	1.50	33.376	33.676	33.50
36	1.50	34.376	34.676	34.50
36	2.00	33.835	34.210	34.00
36	3.00	32.752	33.252	33.00
39	1.50	37.376	37.676	37.50
39	2.00	36.835	37.210	37.00
39	3.00	35.752	36.252	36.00
40	1.50	38.376	38.676	38.50
40	2.00	37.835	38.210	38.00
40	3.00	36.752	37.252	37.00
42	1.50	40.376	40.676	40.50
42	2.00	39.835	40.210	40.00
42	3.00	38.752	39.252	39.00
45	1.50	43.376	43.676	43.50
45	2.00	42.835	43.210	43.00
45	3.00	41.752	42.252	42.00
48	1.50	46.376	46.676	46.50
48	2.00	45.835	46.210	46.00
48	3.00	44.752	45.252	45.00
50	1.50	48.376	48.676	48.50
50	2.00	47.835	48.210	48.00
50	3.00	46.752	47.252	47.00
52	1.50	50.376	50.676	50.50
52	2.00	49.835	50.210	50.00
52	3.00	48.752	49.252	49.00
55	2.00	52.835	53.210	53.00
60	2.00	57.835	58.210	58.00

MF EN 60423:1994, 7H

Ø	P	Внутренний диаметр гайки Core Ø nut		Ø guide line
		Ø mini	Ø maxi	
d ₁	mm			
8	1.00	6.917	7.217	7.00
10	1.00	8.917	9.217	9.00
12	1.50	10.376	10.751	10.50
16	1.50	14.376	14.751	14.50
20	1.50	18.376	18.751	18.50
25	1.50	23.376	23.751	23.50
32	1.50	30.376	30.751	30.50
40	1.50	38.376	38.751	38.50
63	1.50	61.376	61.751	61.50

UNC ASME B1.1, 2B

Ø"	P	P	Внутренний диаметр гайки Core Ø nut		Ø guide line
			Ø mini	Ø maxi	
d ₁	TPI	mm			
1	64	0.397	1.425	1.582	1.45
2	56	0.454	1.695	1.871	1.75
3	48	0.529	1.941	2.146	2.00
4	40	0.635	2.157	2.385	2.25
5	40	0.635	2.487	2.697	2.55
6	32	0.794	2.642	2.895	2.75
8	32	0.794	3.302	3.530	3.40
10	24	1.058	3.683	3.962	3.80
12	24	1.058	4.344	4.597	4.40
1/4"	20	1.270	4.979	5.257	5.10
5/16"	18	1.411	6.401	6.731	6.50
3/8"	16	1.588	7.798	8.153	8.00
7/16"	14	1.814	9.144	9.550	9.30
1/2"	13	1.954	10.592	11.023	10.80
9/16"	12	2.117	11.989	12.446	12.20
5/8"	11	2.309	13.386	13.868	13.60
3/4"	10	2.540	16.307	16.840	16.60
7/8"	9	2.822	19.177	19.761	19.50
1"	8	3.175	21.971	22.606	22.30
1 1/8"	7	3.629	24.638	25.349	25.00
1 1/4"	7	3.629	27.813	28.524	28.20
1 3/8"	6	4.233	30.353	31.115	30.80
1 1/2"	6	4.233	33.528	34.290	34.00
1 3/4"	5	5.080	38.964	39.827	39.50
2"	4.5	5.644	44.679	45.593	45.30

UNJC ISO 3161:1999, 3B

Ø"	P	P	Внутренний диаметр гайки Core Ø nut		Ø guide line
			Ø mini	Ø maxi	
d ₁	TPI	mm			
4	40	0.635	2.228	2.393	2.30
5	40	0.635	2.558	2.723	2.60
6	32	0.794	2.733	2.939	2.80
8	32	0.794	3.393	3.599	3.45
10	24	1.058	3.795	4.064	3.90
12	24	1.058	4.455	4.704	4.55
1/4"	20	1.270	5.113	5.387	5.20
5/16"	18	1.411	6.563	6.833	6.70
3/8"	16	1.588	7.978	8.255	8.10
7/16"	14	1.814	9.347	9.639	9.40
1/2"	13	1.954	10.798	11.095	10.90
9/16"	12	2.117	12.228	12.482	12.40
5/8"	11	2.309	13.627	13.904	13.80
3/4"	10	2.540	16.576	16.881	16.70

ОТВЕРСТИЯ ПОД РЕЗЬБЫ — CORE HOLES

UNF ASME B1.1, 2B

Ø"	P	P	Внутренний диаметр гайки Core Ø nut		Ø guide line
			Ø mini	Ø maxi	
d ₁	TPI	mm			
0	80	0.318	1.182	1.305	1.20
1	72	0.353	1.474	1.612	1.50
2	64	0.397	1.756	1.912	1.80
3	56	0.454	2.025	2.197	2.10
4	48	0.529	2.271	2.458	2.35
5	44	0.577	2.551	2.740	2.60
6	40	0.635	2.820	3.022	2.90
8	36	0.706	3.404	3.606	3.50
10	32	0.794	3.963	4.165	4.05
12	28	0.907	4.496	4.724	4.60
1/4"	28	0.907	5.360	5.588	5.50
5/16"	24	1.058	6.782	7.035	6.90
3/8"	24	1.058	8.382	8.636	8.50
7/16"	20	1.270	9.729	10.033	9.80
1/2"	20	1.270	11.329	11.607	11.40
9/16"	18	1.411	12.751	13.081	12.90
5/8"	18	1.411	14.351	14.681	14.50
3/4"	16	1.588	17.323	17.678	17.50
7/8"	14	1.814	20.270	20.675	20.40
1"	12	2.117	23.114	23.571	23.30
1 1/8"	12	2.117	26.289	26.746	26.50
1 1/4"	12	2.117	29.464	29.921	29.70
1 3/8"	12	2.117	32.639	33.096	32.80
1 1/2"	12	2.117	35.814	36.271	36.00

UNJF ISO 3161:1999, 3B

Ø"	P	P	Внутренний диаметр гайки Core Ø nut		Ø guide line
			Ø mini	Ø maxi	
d ₁	TPI	mm			
0	80	0.318	1.217	1.298	1.25
1	72	0.353	1.511	1.603	1.55
2	64	0.397	1.798	1.902	1.85
3	56	0.454	2.073	2.189	2.10
4	48	0.529	2.329	2.466	2.35
5	44	0.577	2.614	2.764	2.65
6	40	0.635	2.888	3.053	2.95
8	36	0.706	3.480	3.663	3.55
10	32	0.794	4.054	4.255	4.10
12	28	0.907	4.602	4.816	4.70
1/4"	28	0.907	5.466	5.662	5.55
5/16"	24	1.058	6.906	7.109	7.00
3/8"	24	1.058	8.494	8.679	8.60
7/16"	20	1.270	9.876	10.084	10.00
1/2"	20	1.270	11.463	11.661	11.55
9/16"	18	1.411	12.913	13.122	13.05
5/8"	18	1.411	14.501	14.702	14.60
3/4"	16	1.588	17.506	17.722	17.60
7/8"	14	1.814	20.460	20.706	20.60
1"	12	2.117	23.340	23.594	23.50

UNEF ASME B1.1, 2B

Ø"	P	P	Внутренний диаметр гайки Core Ø nut		Ø guide line
			Ø mini	Ø maxi	
d ₁	TPI	mm			
12	32	0.794	4.623	4.826	4.70
1/4"	32	0.794	5.487	5.689	5.60
5/16"	32	0.794	7.087	7.264	7.20
3/8"	32	0.794	8.662	8.864	8.75
7/16"	28	0.907	10.135	10.337	10.25
1/2"	28	0.907	11.710	11.938	11.85
9/16"	24	1.058	13.132	13.385	13.20
5/8"	24	1.058	14.732	14.986	14.80
11/16"	24	1.058	16.307	16.560	16.40
3/4"	20	1.270	17.679	17.957	17.80
13/16"	20	1.270	19.254	19.558	19.40
7/8"	20	1.270	20.854	21.132	21.00
1"	20	1.270	24.029	24.307	24.10

UN ASME B1.1, 2B

Ø"	P	P	Внутренний диаметр гайки Core Ø nut		Ø guide line
			Ø mini	Ø maxi	
d ₁	TPI	mm			
5/16"	20	1.270	6.554	6.858	6.70
3/8"	20	1.270	8.154	8.432	8.30
9/16"	20	1.270	12.904	13.208	13.00
5/8"	20	1.270	14.504	14.782	14.60
1 1/8"	8	3.175	25.146	25.781	25.50
1 1/4"	8	3.175	28.321	28.956	28.70
1 3/8"	8	3.175	31.496	32.131	31.80
1 1/2"	8	3.175	34.671	35.306	35.00
1 5/8"	8	3.175	37.846	38.481	38.20
1 3/4"	8	3.175	41.021	41.656	41.40
1 7/8"	8	3.175	44.196	44.831	44.50
2"	8	3.175	47.371	48.006	47.70
2 1/4"	8	3.175	53.721	54.356	54.10
2 1/2"	8	3.175	60.071	60.706	60.40

UNS ASME B1.1, 2B

Ø"	P	P	Внутренний диаметр гайки Core Ø nut		Ø guide line
			Ø mini	Ø maxi	
d ₁	TPI	mm			
10	36	0.706	4.064	4.216	4.10
10	40	0.635	4.141	4.292	4.20
10	56	0.454	4.344	4.445	4.40
1/4"	36	0.706	5.588	5.740	5.65
1/4"	40	0.635	5.665	5.816	5.70
1/4"	48	0.529	5.766	5.892	5.80
1/4"	56	0.454	5.868	5.969	5.90
5/16"	36	0.706	7.163	7.340	7.25
3/8"	36	0.706	8.763	8.940	8.80
7/16"	24	1.058	9.957	10.210	10.00
1/2"	24	1.058	11.557	11.811	11.60
1"	14	1.814	23.445	23.825	23.60

ОТВЕРСТИЯ ПОД РЕЗЬБЫ — CORE HOLES

G (BSP) DIN EN ISO 228

Ø"	P	P	Внутренний диаметр гайки Core Ø nut			
			Ø mini	Ø maxi	Ø guide line	
d _i	TPI	mm				
1/16"	28	0.907	6.561	6.843	6.75	
1/8"	28	0.907	8.566	8.848	8.75	
1/4"	19	1.337	11.445	11.890	11.60	
3/8"	19	1.337	14.950	15.395	15.20	
1/2"	14	1.814	18.631	19.172	18.90	
5/8"	14	1.814	20.587	21.128	20.90	
3/4"	14	1.814	24.117	24.658	24.40	
7/8"	14	1.814	27.877	28.418	28.20	
1"	11	2.309	30.291	30.931	30.70	
1 1/8"	11	2.309	34.939	35.579	35.30	
1 1/4"	11	2.309	38.952	39.592	39.30	
1 3/8"	11	2.309	41.365	42.005	41.80	
1 1/2"	11	2.309	44.845	45.485	45.20	
1 3/4"	11	2.309	50.788	51.428	51.20	
2"	11	2.309	56.656	57.296	57.00	
2 1/4"	11	2.309	62.752	63.392	63.10	
2 1/2"	11	2.309	72.226	72.866	72.60	
3"	11	2.309	84.926	85.566	85.30	

W (BSW) BS 84, (DIN 11 - 1970)

Ø"	P	P	Внутренний диаметр гайки Core Ø nut			
			Ø mini	Ø maxi	Ø guide line	
d _i	TPI	mm				
(3/32")	48				1.80	
1/8"	40	0.635	2.362	2.591	2.50	
(5/32")	32				3.10	
3/16"	24	1.058	3.406	3.744	3.60	
(7/32")	24				4.40	
1/4"	20	1.270	4.724	5.156	4.90	
5/16"	18	1.411	6.129	6.588	6.40	
3/8"	16	1.588	7.493	7.988	7.70	
7/16"	14	1.814	8.791	9.332	9.10	
1/2"	12	2.117	9.987	10.589	10.30	
5/8"	11	2.309	12.918	13.558	13.30	
3/4"	10	2.540	15.799	16.484	16.20	
7/8"	9	2.822	18.613	19.355	19.25	
1"	8	3.175	21.336	22.149	21.90	

TR ISO 2901-2904, DIN 103, 7H

Ø	P	Внутренний диаметр гайки Core Ø nut			
		Ø mini	Ø maxi	Ø guide line	
d _i	mm				
10	2	8	8.236	8.20	
12	3	9	9.315	9.25	
14	3	11	11.315	11.25	
16	4	12	12.375	12.25	
18	4	14	14.375	14.25	
20	4	16	16.375	16.25	
22	5	17	17.450	17.25	
24	5	19	19.450	19.25	
26	5	21	21.450	21.25	
28	5	23	23.450	23.25	
30	6	24	24.500	24.25	
32	6	26	26.500	26.25	

PG DIN 40430

Ø	P	P	Внутренний диаметр гайки Core Ø nut			
			Ø mini	Ø maxi	Ø guide line	
d _i	TPI	mm				
7	20	1.270	11.28	11.43	11.35	
9	18	1.411	13.86	14.01	13.90	
11	18	1.411	17.26	17.41	17.30	
13.5	18	1.411	19.06	19.21	19.10	
16	18	1.411	21.16	21.31	21.20	
21	16	1.588	26.78	27.03	26.80	
29	16	1.588	35.48	35.73	35.50	
36	16	1.588	45.48	45.73	45.50	
42	16	1.588	52.48	52.73	52.50	
48	16	1.588	57.78	58.03	57.80	

S NIHS 06-10, 3G5H (стандартный - standard tol.)

Ø	P	Внутренний диаметр гайки Core Ø nut			
		Ø mini	Ø maxi	Ø guide line	
d _i	mm				
0.3	0.080	0.223	0.240	0.23	
0.35	0.090	0.264	0.286	0.28	
0.4	0.100	0.304	0.330	0.32	
0.5	0.125	0.380	0.415	0.41	
0.6	0.150	0.456	0.502	0.50	
0.7	0.175	0.532	0.585	0.58	
0.8	0.200	0.608	0.665	0.66	
0.9	0.225	0.684	0.745	0.74	
1	0.250	0.760	0.825	0.82	
1.2	0.250	0.960	1.025	1.02	
1.4	0.300	1.112	1.185	1.18	



SF NIHS 06-10, 3G5H (стандартный - standard tol.)

Ø	P	Внутренний диаметр гайки Core Ø nut			
		Ø mini	Ø maxi	Ø guide line	
d _i	mm				
1.4	0.200	1.208	1.265	1.26	
1.6	0.200	1.408	1.465	1.46	
1.8	0.200	1.608	1.665	1.66	
2	0.200	1.808	1.865	1.86	
2.2	0.200	2.008	2.065	2.06	
2.2	0.250	1.960	2.025	2.02	
2.5	0.200	2.308	2.365	2.36	
2.5	0.250	2.260	2.325	2.32	

SL Safelock SL 15-01

Ø	P	Внутренний диаметр гайки Core Ø nut			
		Ø mini	Ø maxi	Ø guide line	
d _i	mm				
0.3	0.060	0.264	0.278	0.27	
0.35	0.060	0.314	0.328	0.32	
0.4	0.080	0.356	0.372	0.36	
0.5	0.100	0.448	0.466	0.46	
0.6	0.125	0.538	0.559	0.55	
0.7	0.150	0.628	0.651	0.64	
0.8	0.150	0.728	0.751	0.74	
0.9	0.175	0.818	0.844	0.83	
1	0.200	0.908	0.936	0.92	
1.2	0.200	1.108	1.136	1.12	
1.4	0.250	1.288	1.321	1.30	

ДИАМЕТРЫ ПОД ПЛАШКИ — TURNED DIAMETERS

M					MF				
DIN 13, ISO 261, *6h / 6g					DIN 13, ISO 261, 6g				
\emptyset	P	Наружный диаметр резьбы Thread outside \emptyset			\emptyset	P	Наружный диаметр резьбы Thread outside \emptyset		
d_1	mm	\emptyset mini	\emptyset maxi	\emptyset guide line	d_1	mm	\emptyset mini	\emptyset maxi	\emptyset guide line
*1	0.25	0.933	1.000	0.97	8	1.00	7.794	7.974	7.88
*1.1	0.25	1.033	1.100	1.07	9	0.75	8.838	8.978	8.90
*1.2	0.25	1.133	1.200	1.17	9	1.00	8.794	8.974	8.88
*1.4	0.30	1.325	1.400	1.36	10	0.75	9.838	9.978	9.90
1.6	0.35	1.496	1.581	1.54	10	1.00	9.794	9.974	9.88
1.7	0.35	1.596	1.681	1.64	10	1.25	9.760	9.972	9.86
1.8	0.35	1.696	1.781	1.74	11	0.75	10.838	10.978	10.90
2	0.40	1.886	1.981	1.93	11	1.00	10.794	10.974	10.88
2.2	0.45	2.080	2.180	2.13	12	1.00	11.794	11.974	11.88
2.3	0.40	2.186	2.300	2.23	12	1.25	11.760	11.972	11.86
2.5	0.45	2.380	2.480	2.43	12	1.50	11.732	11.968	11.85
2.6	0.45	2.480	2.600	2.53	14	1.00	13.794	13.974	13.88
3	0.50	2.874	2.980	2.92	14	1.25	13.760	13.972	13.86
3.5	0.60	3.354	3.479	3.41	14	1.50	13.732	13.968	13.85
4	0.70	3.838	3.978	3.91	15	1.00	14.794	14.974	14.88
4.5	0.75	4.338	4.478	4.40	15	1.50	14.732	14.968	14.85
5	0.80	4.826	4.976	4.90	16	1.00	15.794	15.974	15.88
6	1.00	5.794	5.974	5.88	16	1.50	15.732	15.968	15.85
7	1.00	6.794	6.974	6.88	17	1.00	16.794	16.974	16.88
8	1.25	7.760	7.972	7.87	17	1.50	16.732	16.968	16.85
9	1.25	8.760	8.972	8.87	18	1.00	17.794	17.974	17.88
10	1.50	9.732	9.968	9.85	18	1.50	17.732	17.968	17.85
11	1.50	10.732	10.968	10.85	18	2.00	17.682	17.962	17.82
12	1.75	11.701	11.966	11.83	20	1.00	19.794	19.974	19.88
14	2.00	13.682	13.962	13.82	20	1.50	19.732	19.968	19.85
16	2.00	15.682	15.962	15.82	20	2.00	19.682	19.962	19.82
18	2.50	17.623	17.958	17.79	22	1.00	21.794	21.974	21.88
20	2.50	19.623	19.958	19.79	22	1.50	21.732	21.968	21.85
22	2.50	21.623	21.958	21.79	22	2.00	21.682	21.962	21.82
24	3.00	23.577	23.952	23.76	24	1.00	23.794	23.974	23.88
27	3.00	26.577	26.952	26.76	24	1.50	23.732	23.968	23.85
30	3.50	29.522	29.947	29.73	24	2.00	23.682	23.962	23.82
33	3.50	32.522	32.947	32.73	25	1.00	24.794	24.974	24.88
36	4.00	35.465	35.940	35.70	25	1.50	24.732	24.968	24.85
39	4.00	38.465	38.940	38.70	25	2.00	24.682	24.962	24.82
42	4.50	41.437	41.937	41.69	27	1.00	26.794	26.974	26.88
45	4.50	44.437	44.937	44.69	27	1.50	26.732	26.968	26.85
48	5.00	47.399	47.929	47.66	27	2.00	26.682	26.962	26.82
52	5.00	51.399	51.929	51.66	28	1.00	27.794	27.974	27.88
56	5.50	55.365	55.925	55.65	28	1.50	27.732	27.968	27.85
					28	2.00	27.682	27.962	27.82
					30	1.00	29.794	29.974	29.88
					30	1.50	29.732	29.968	29.85
					30	2.00	29.682	29.962	29.82
					30	3.00	29.577	29.952	29.76
					32	1.50	31.732	31.968	31.85
					32	2.00	31.682	31.962	31.82
					33	1.50	32.732	32.968	32.85
					33	2.00	32.682	32.962	32.82
					33	3.00	32.577	32.952	32.76
					35	1.50	34.732	34.968	34.85
					36	1.50	35.732	35.968	35.85
					36	2.00	35.682	35.962	35.82
					36	3.00	35.577	35.952	35.76
					39	1.50	38.732	38.968	38.85
					39	2.00	38.682	38.962	38.82
					39	3.00	38.577	38.952	38.76

ДИАМЕТРЫ ПОД ПЛАШКИ — TURNED DIAMETERS

MF DIN 13, ISO 261, 6g

Ø	P	Наружный диаметр резьбы Thread outside Ø			
		Ø mini	Ø maxi	Ø guide line	
d ₁	mm				
40	1.50	39.732	39.968	39.85	
40	2.00	39.682	39.962	39.82	
40	3.00	39.577	39.952	39.76	
42	1.50	41.732	41.968	41.85	
42	2.00	41.682	41.962	41.82	
42	3.00	41.577	41.952	41.76	
45	1.50	44.732	44.968	44.85	
45	2.00	44.682	44.962	44.82	
45	3.00	44.577	44.952	44.76	
48	1.50	47.732	47.968	47.85	
48	2.00	47.682	47.962	47.82	
48	3.00	47.577	47.952	47.76	
50	1.50	49.732	49.968	49.85	
50	2.00	49.682	49.962	49.82	
50	3.00	49.577	49.952	49.76	
52	1.50	51.732	51.968	51.85	
52	2.00	51.682	51.962	51.82	
52	3.00	51.577	51.952	51.76	
52	4.00	51.465	51.940	51.70	

UNF ASME B.1.1, 2A

Ø"	P	P	Наружный диаметр резьбы Thread outside Ø			
			Ø mini	Ø maxi	Ø guide line	
d ₁	TPI	mm				
0	80	0.318	1.431	1.511	1.47	
1	72	0.353	1.751	1.838	1.79	
2	64	0.397	2.073	2.169	2.12	
3	56	0.454	2.393	2.496	2.44	
4	48	0.529	2.713	2.827	2.77	
5	44	0.577	3.036	3.157	3.10	
6	40	0.635	3.356	3.484	3.42	
8	36	0.706	4.006	4.145	4.08	
10	32	0.794	4.651	4.803	4.73	
12	28	0.907	5.296	5.461	5.38	
1/4"	28	0.907	6.160	6.324	6.24	
5/16"	24	1.058	7.727	7.909	7.82	
3/8"	24	1.058	9.315	9.497	9.41	
7/16"	20	1.270	10.874	11.079	10.98	
1/2"	20	1.270	12.462	12.666	12.56	
9/16"	18	1.411	14.031	14.251	14.14	
5/8"	18	1.411	15.619	15.839	15.73	
3/4"	16	1.588	18.774	19.011	18.89	
7/8"	14	1.814	21.923	22.184	22.05	
1"	12	2.117	25.065	25.354	25.21	
1 1/8"	12	2.117	28.240	28.529	28.38	
1 1/4"	12	2.117	31.415	31.704	31.56	
1 3/8"	12	2.117	34.588	34.876	34.73	
1 1/2"	12	2.117	37.763	38.051	37.91	

UNC ASME B.1.1, 2A

Ø"	P	P	Наружный диаметр резьбы Thread outside Ø			
			Ø mini	Ø maxi	Ø guide line	
d ₁	TPI	mm				
1	64	0.397	1.743	1.838	1.79	
2	56	0.454	2.066	2.169	2.12	
3	48	0.529	2.383	2.496	2.44	
4	40	0.635	2.695	2.824	2.76	
5	40	0.635	3.026	3.154	3.09	
6	32	0.794	3.333	3.484	3.41	
8	32	0.794	3.991	4.142	4.07	
10	24	1.058	4.618	4.800	4.71	
12	24	1.058	5.279	5.461	5.37	
1/4"	20	1.270	6.117	6.322	6.22	
5/16"	18	1.411	7.687	7.907	7.80	
3/8"	16	1.588	9.254	9.491	9.37	
7/16"	14	1.814	10.816	11.076	10.95	
1/2"	13	1.954	12.386	12.661	12.52	
9/16"	12	2.117	13.958	14.246	14.10	
5/8"	11	2.309	15.528	15.834	15.68	
3/4"	10	2.540	18.677	19.004	18.84	
7/8"	9	2.822	21.824	22.176	22.00	
1"	8	3.175	24.969	25.349	25.16	
1 1/8"	7	3.629	28.103	28.519	28.31	
1 1/4"	7	3.629	31.278	31.694	31.49	
1 3/8"	6	4.233	34.402	34.864	34.63	
1 1/2"	6	4.233	37.577	38.039	37.81	
1 3/4"	5	5.080	43.860	44.381	44.12	
2"	4.5	5.644	50.168	50.726	50.45	
2 1/4"	4.5	5.644	56.518	57.076	56.80	
2 1/2"	4	6.350	62.817	63.421	63.12	
2 3/4"	4	6.350	69.165	69.768	69.47	
3"	4	6.350	75.515	76.118	75.82	
3 1/4"	4	6.350	81.862	82.466	82.16	
3 1/2"	4	6.350	88.212	88.816	88.51	
3 3/4"	4	6.350	94.560	95.163	94.86	
4"	4	6.350	100.910	101.513	101.21	

UNEF ASME B.1.1, 2A

Ø"	P	P	Наружный диаметр резьбы Thread outside Ø			
			Ø mini	Ø maxi	Ø guide line	
d ₁	TPI	mm				
12	32	0.794	5.312	5.463	5.39	
1/4"	32	0.794	6.173	6.324	6.25	
5/16"	32	0.794	7.760	7.912	7.84	
3/8"	32	0.794	9.348	9.499	9.42	
7/16"	28	0.907	10.920	11.084	11.00	
1/2"	28	0.907	12.507	12.672	12.59	
9/16"	24	1.058	14.075	14.257	14.17	
5/8"	24	1.058	15.662	15.844	15.75	
11/16"	24	1.058	17.250	17.432	17.34	
3/4"	20	1.270	18.812	19.016	18.91	
13/16"	20	1.270	20.339	20.604	20.50	
7/8"	20	1.270	21.987	22.191	22.09	
15/16"	20	1.270	23.572	23.776	23.67	
1"	20	1.270	25.159	25.364	25.26	
1 1/8"	18	1.411	28.319	28.539	28.43	
1 1/4"	18	1.411	31.491	31.711	31.60	
1 1/2"	18	1.411	37.841	38.061	37.95	

UN ASME B.1.1, 2A

Ø"	P	P	Наружный диаметр резьбы Thread outside Ø			
			Ø mini	Ø maxi	Ø guide line	
d ₁	TPI	mm				
5/16"	20	1.270	7.702	7.907	7.80	
3/8"	20	1.270	9.289	9.494	9.39	
9/16"	20	1.270	14.049	14.254	14.15	
5/8"	20	1.270	15.637	15.841	15.74	

ДИАМЕТРЫ ПОД ПЛАШКИ — TURNED DIAMETERS

UN ASME B1.1, 2A

Ø"	P	P	Наружный диаметр резьбы Thread outside Ø		
			Ø mini	Ø maxi	Ø guide line
d ₁	TPI	mm			
1 1/8"	8	3.175	28.141	28.521	28.33
1 1/4"	8	3.175	31.316	31.696	31.51
1 3/8"	8	3.175	34.489	34.869	34.68
1 1/2"	8	3.175	37.664	38.044	37.85
1 5/8"	8	3.175	40.839	41.219	41.03
1 3/4"	8	3.175	44.011	44.391	44.20
1 7/8"	8	3.175	47.186	47.566	47.38
2"	8	3.175	50.361	50.741	50.55
2 1/4"	8	3.175	56.709	57.089	56.90
2 1/2"	8	3.175	63.059	63.439	63.25
2 3/4"	8	3.175	69.406	69.786	69.60
3"	8	3.175	75.753	76.133	75.94

UNS ASME B1.1, 2A

Ø"	P	P	Наружный диаметр резьбы Thread outside Ø		
			Ø mini	Ø maxi	Ø guide line
d ₁	TPI	mm			
10	36	0.706	4.664	4.803	4.73
10	40	0.635	4.674	4.803	4.74
10	56	0.454	4.705	4.808	4.76
1/4"	36	0.706	6.188	6.327	6.26
1/4"	40	0.635	6.198	6.327	6.26
1/4"	48	0.529	6.216	6.329	6.27
1/4"	56	0.454	6.226	6.329	6.28
5/16"	36	0.706	7.775	7.914	7.84
3/8"	36	0.706	9.360	9.499	9.43
7/16"	24	1.058	10.902	11.084	10.99
1/2"	24	1.058	12.487	12.669	12.58
1"	14	1.814	25.096	25.356	25.23

G (BSP) DIN EN ISO 228

Ø"	P	P	Наружный диаметр резьбы Thread outside Ø		
			Ø mini	Ø maxi	Ø guide line
d ₁	TPI	mm			
1/16"	28	0.907	7.509	7.723	7.62
1/8"	28	0.907	9.514	9.728	9.62
1/4"	19	1.337	12.907	13.157	13.03
3/8"	19	1.337	16.412	16.662	16.54
1/2"	14	1.814	20.671	20.955	20.81
5/8"	14	1.814	22.627	22.911	22.77
3/4"	14	1.814	26.157	26.441	26.30
7/8"	14	1.814	29.917	30.201	30.06
1"	11	2.309	32.889	33.249	33.07
1 1/8"	11	2.309	37.537	37.897	37.72
1 1/4"	11	2.309	41.550	41.910	41.73
1 3/8"	11	2.309	43.963	44.323	44.14
1 1/2"	11	2.309	47.443	47.803	47.62
1 3/4"	11	2.309	53.386	53.746	53.57
2"	11	2.309	59.254	59.614	59.43
2 1/4"	11	2.309	65.276	65.710	65.49
2 1/2"	11	2.309	74.750	75.184	74.97
2 3/4"	11	2.309	81.100	81.534	81.32
3"	11	2.309	87.450	87.884	87.67
3 1/2"	11	2.309	99.896	100.330	100.11

W (BSW) BS 84

Ø"	P	P	Наружный диаметр резьбы Thread outside Ø		
			Ø mini	Ø maxi	Ø guide line
d ₁	TPI	mm			
1/4"	20	1.270	6.165	6.319	6.24
5/16"	18	1.411	7.737	7.904	7.82
3/8"	16	1.588	9.312	9.489	9.40
7/16"	14	1.814	10.884	11.074	10.98
1/2"	12	2.117	12.456	12.662	12.56
5/8"	11	2.309	15.613	15.832	15.72
3/4"	10	2.540	18.771	19.004	18.89
7/8"	9	2.822	21.979	22.225	22.10
1"	8	3.175	25.138	25.400	25.27
1 1/8"	7	3.629	28.296	28.575	28.44
1 1/4"	7	3.629	31.465	31.750	31.61
1 1/2"	6	4.233	37.793	38.100	37.95
1 3/4"	5	5.080	44.117	44.450	44.28
2"	4.5	5.644	50.449	50.800	50.62
2 1/4"	4	6.350	56.779	57.150	56.96
2 1/2"	4	6.350	63.119	63.500	63.31

TR ISO 2901-2904, DIN 103, 7e

Ø	P	P	Наружный диаметр резьбы Thread outside Ø		
			Ø mini	Ø maxi	Ø guide line
d ₁	mm				
10	2		9.820	10.000	9.91
12	3		11.764	12.000	11.88
14	3		13.764	14.000	13.88
16	4		15.700	16.000	15.85
18	4		17.700	18.000	17.85
20	4		19.700	20.000	19.85
22	5		21.665	22.000	21.83
24	5		23.665	24.000	23.83
26	5		25.665	26.000	25.83
28	5		27.665	28.000	27.83
30	6		29.625	30.000	29.81
32	6		31.625	32.000	31.81

PG DIN 40430

Ø	P	P	Наружный диаметр резьбы Thread outside Ø		
			Ø mini	Ø maxi	Ø guide line
d ₁	TPI	mm			
7	20	1.270	12.3	12.5	12.40
9	18	1.411	15.0	15.2	15.10
11	18	1.411	18.4	18.6	18.50
13.5	18	1.411	20.2	20.4	20.30
16	18	1.411	22.3	22.5	22.40
21	16	1.588	28.0	28.3	28.15
29	16	1.588	36.7	37.0	36.85
36	16	1.588	46.7	47.0	46.85
42	16	1.588	53.7	54.0	53.85
48	16	1.588	59.0	59.3	59.15

Запрос <input type="checkbox"/>	Результат испытаний <input type="checkbox"/>	Претензии <input type="checkbox"/>
Агент: _____		Контактное лицо: _____
Потребитель: _____		E-Mail: _____
Телефон или факс: _____		Дата: _____
1. Тип инструмента: _____		Размер резьбы: _____
Частности: _____		Класс точности: _____
2. Группа материалов: _____		
Но материала: _____		Твердость: _____ N/mm ² / HB / HRC
Стандарт: _____		Удлинение: _____ %
3. Резьба: <input type="checkbox"/> Глухое <input type="checkbox"/> Сквозное		Длина нарезания резьбы: _____ mm
Диаметр отверстия под резьбу: _____		Глубина: _____ mm
Диаметр зенкера: _____		Глубина: _____ mm
4. Скорость резания: _____ m/min		_____ 1/min
Подача (f): _____ %		
5. Станок: _____		<input type="checkbox"/> Внутренняя подача СОЖ
Рабочее положение: <input type="checkbox"/> Горизонтальное <input type="checkbox"/> Вертикальное		
Скоростное нарезание резьбы с ЧПУ: <input type="checkbox"/> Патрон с плавающим осевым амортизатором SRT <input type="checkbox"/> Велдон <input type="checkbox"/> Weldon <input type="checkbox"/> Горячий/холодный термopatрон		Тип патрона: <input type="checkbox"/> Осевая компенсация <input type="checkbox"/> Патрон с предохранительной муфтой <input type="checkbox"/> Реверсивный <input type="checkbox"/> Скользящая муфта
6. Смазка: <input type="checkbox"/> Эмульсия <input type="checkbox"/> Масло <input type="checkbox"/> Воздух <input type="checkbox"/> Аэрозоль		
Наименование: _____		
7. Причина замены инструмента: <input type="checkbox"/> Износ инструмента <input type="checkbox"/> Несоответствие резьбы калибру <input type="checkbox"/> Ошибка станка		<input type="checkbox"/> Поломка инструмента <input type="checkbox"/> Поломка в заходной части <input type="checkbox"/> Поломка в резьбовой части
8. Сравнение эффективности:		
Испытываемый инструмент: _____		
Результаты и замечания: _____		
Примечания: _____		

Enquiry

Test result

Complaint

Agency: _____
Customer: _____
Phone or fax: _____

Contact: _____
E-mail: _____
Date: _____

1. Tool type: _____
Particularity: _____

Thread size: _____
Class of tolerance: _____

2. Material group: _____
Material N°: _____
Norm: _____

Hardness: _____ N/mm² / HB / HRC
Elongation: _____ %

3. Thread: blind hole through hole

Threaded length: _____ mm

Core hole Ø: _____

Depth: _____ mm

Counter-bore Ø: _____

Depth: _____ mm

4. Cutting speed (V_c): _____ m/min _____ l/min

Feed (f): _____ %

5. Machine: _____ internal coolant

Working position: horizontal

vertical

Rigid Tapping: "Soft Rigid Tapping"

Tapping spindle: axial compensation

collet

de-clutching

Weldon

reversible

hot / cold shrunk

sliding clutch

6. Lubricant: emulsion cutting oil air mist

Product: _____

7. Tool change reason: tool wear

tool breakage

thread not correct (checked with thread plug gauge)

tooth breakage in the chamfer lead

machine error

tooth breakage in the guiding thread

8. Efficiency comparison:

Tool under test: _____

Performance and observations: _____

Remarks: _____

**ВСЕ НАШИ ИНСТРУМЕНТЫ МОЖНО ЗАКАЗАТЬ В
ЛЮБОЕ ВРЕМЯ ЧЕРЕЗ НАШ ИНТЕРНЕТ-МАГАЗИН.
ЗАРЕГИСТРИРУЙТЕСЬ СЕЙЧАС: DCSWISS.COM**

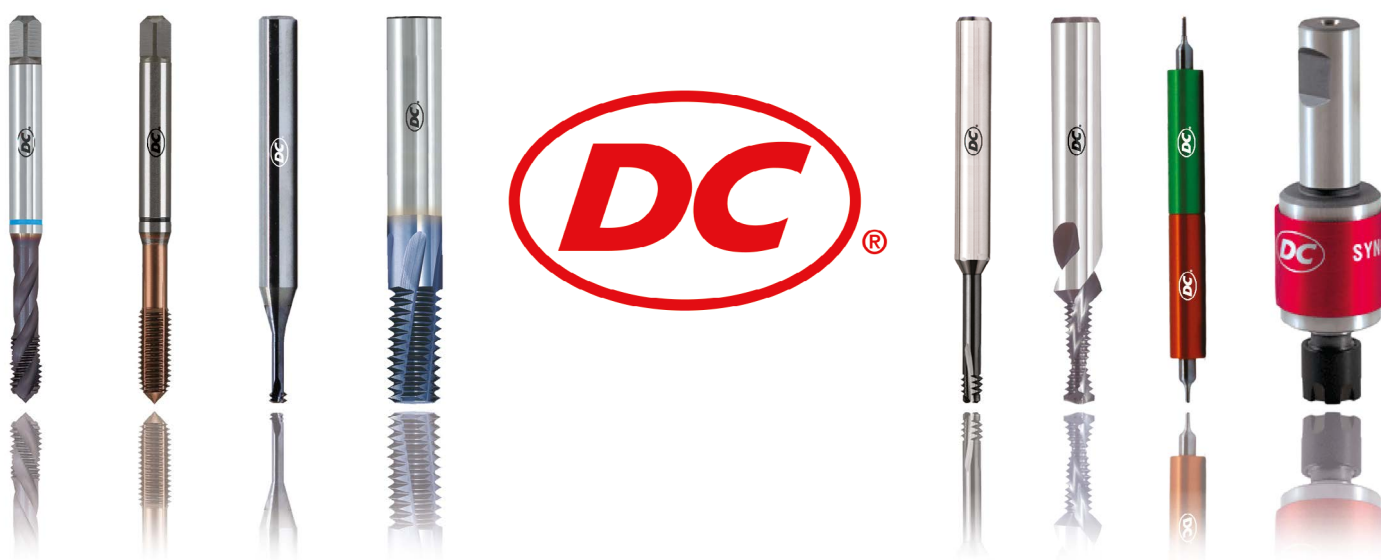

**YOU FIND
ALL THESE TOOLS ON OUR **WEBSHOP**
REGISTER NOW: DCSWISS.COM**

ЦЕНОВЫЕ ДОПОЛНЕНИЯ — PRICE SUPPLEMENTS

Возможные модификации стандартных метчиков без покрытия и обработки поверхности

Цена и сроки поставки по запросу

Изменение угла заточки (от \varnothing 5 мм)
Дополнительная обработка режущих кромок ($\varnothing \leq 52$ мм)
Удлинение заходной части (от \varnothing 2.5 мм)
Укорачивание заходной части (от \varnothing 2.5 мм)
Вышлифовка стружколомающей фаски (от \varnothing 5 мм)
Изменение параметра l3, d2 или d4
Удлинение канавок ($\varnothing \geq 5$ мм - ≤ 48 мм)
Удаление центрального конуса ($\varnothing \geq 1$ мм - ≤ 12 мм)
Увеличенное стружечное пространство (от \varnothing 3 мм)
Шахматное расположение зубьев (от шага 0.5 мм)
Вышлифовка лыски под Велдон ($\varnothing \geq 6$ мм - ≤ 16 мм)
Внутренний канал СОЖ, фронтальный выход ($\varnothing \geq 3$ мм - ≤ 25.4 мм)
Внутренний канал СОЖ, радиальный выход ($\varnothing \geq 3$ мм - ≤ 25.4 мм)
Плазменное азотирование + "V" обработка поверхности
DC "V" обработка поверхности
Покрытия TiN, TiCN, VS, CrN, HL, ...
Дополнительная маркировка

Укорачивание секции сверла (N5951-SP; N5952-SP)

Разумеется, мы также производим резьбонарезные инструменты по Вашему чертежу в соответствии с требованиями заказчика. Цена и сроки поставки по запросу.

Possible modifications of non-coated and non-surface treated standard taps

Price and delivery time on request

Modification of cutting angle (from \varnothing 5 mm)
Conditioning of cutting edges ($\varnothing \leq 52$ mm)
Lengthening of chamfer (from \varnothing 2.5 mm)
Shortening of chamfer (from \varnothing 2.5 mm)
Grinding of peeling cut (from \varnothing 5 mm)
Modification of l3, d2, a or d4
Lengthening of flutes ($\varnothing \geq 5$ mm - ≤ 48 mm)
Removal of center point ($\varnothing \geq 1$ mm - ≤ 12 mm)
Interrupted thread (from pitch 0.5 mm)
Truncated thread (from \varnothing 3 mm)
Grinding the Weldon Surface ($\varnothing \geq 6$ mm - ≤ 16 mm)
Internal coolant, with frontal outflow ($\varnothing \geq 3$ mm - ≤ 25.4 mm)
Internal coolant, with radial outflow ($\varnothing \geq 3$ mm - ≤ 25.4 mm)
NV-Plasma nitriding + "V" surface treatment
DC "V" surface treatment
Coatings: TiN, TiCN, VS, CrN, HL, etc.
Additional marking
Shortening of drill section (N5951-SP; N5952-SP)

Of course we also produce customised threading tools as per your drawings.

Price and delivery time on request.

УСЛОВИЯ ПОСТАВКИ И ОПЛАТЫ

Заказы	<p>По заказам, которые не могут быть отгружены немедленно, будут сообщены сроки поставки. На изделия, которые более не относятся к стандартной программе, но присутствуют в каталоге, цены будут указаны как на „специальные“. Заказ может быть аннулирован только совместным письменным соглашением.</p>
Ценовые предложения и уведомления	<p>По причине постоянного развития все характеристики, упомянутые в наших предложениях, приложениях, указаниях весов, измерений, также как и иллюстрации и чертежи указывают приближенные значения. Эти технические данные имеют обязательное значение только там, где оговорено дополнительно.</p>
Цены	<p>Наши цены указаны при условиях поставки ex works Malleray, без учета НДС, упаковки, страховки, фрахта, таможенных и регистрационных сборов. В случае роста цен, мы оставляем за собой право выставить счета по уже измененным ценам.</p>
Платежи	<p>Платежи должны производиться в форме аванса или в форме безотзывного подтвержденного аккредитива открытого в нашу пользу в Швейцарском банке. Все банковские комиссии и сборы должны быть уплачены покупателем.</p>
Право собственности	<p>Мы оставляем за собой право собственности на все поставляемые товары до тех пор, пока цена продажи плюс побочные расходы не будут нам полностью оплачены покупателем.</p>
Отгрузка	<p>Все риски, связанные с поставкой, относятся на счет покупателя.</p>
Поставка	<p>Подтвержденные сроки поставки не являются обязывающими. Мы сделаем все от нас зависящее, чтобы выдержать их. Однако мы не можем нести ответственности за прямые или косвенные потери, возникшие по причине задержки поставки.</p>
Специальные заказы	<p>При исполнении специальных заказов мы оставляем за собой право на количественные колебания изделий в пределах 15%, или при небольших заказах 1 или 2 штуки.</p>
Гарантии	<p>Инструменты, признанные бракованными по вине DC будут заменены бесплатно, но без возмещения каких бы то ни было прочих убытков.</p>
Претензии	<p>Претензии принимаются в течение 15 дней с даты получения товара.</p>
Чертежи и эскизы	<p>Воспроизведение или передача чертежей и прочих документов третьим сторонам запрещены. Информация (чертежи и иллюстрации) в нашем каталоге являются информационными но не обязательными.</p>
Специальные условия	<p>В случае частичной или полной остановки нашего производства мы оставляем за собой право частично или полностью отказаться от обязательств по поставке.</p>
Арбитраж	<p>Все споры разрешаются в соответствии со Швейцарским законодательством aw. Местонахождение арбитражного суда – Мотье (Moutier), Швейцария.</p>

DELIVERY AND PAYMENT CONDITIONS

Orders	Orders, which cannot be delivered from stock, will be acknowledged. Items, which do not belong any more to our standard programme, although still featured in the catalogue, will be invoiced as «specials». Orders may only be cancelled by mutual written agreement.
Quotations and acknowledgements	For reasons of constant development in this field, all descriptions mentioned in our quotations, annexed documents, weight indications, measurements as well as illustrations and drawings are approximate indications. These technical data have binding value only if expressly specified.
Prices	Our prices are quoted for deliveries ex works Malleray, excluding VAT, packing, insurance, freight, customs' and legalisation duties. Should prices increase, we reserve the right to invoice tools already acknowledged at the new prices.
Payment	Payments must be made in advance or against irrevocable and confirmed documentary credit to be opened in our favour with a Swiss bank. All banking commissions and charges have to be borne by the buyer.
Right of ownership	We reserve the right of ownership of all goods supplied until the sales price, plus all incidental charges, have fully been paid.
Despatch	Deliveries take place at the purchaser's risk.
Delivery	Confirmed delivery dates are non-binding. We will do our utmost to maintain them. However, we cannot accept responsibility of direct or consequential losses due to delayed deliveries.
Special orders	For all special tools we reserve the right to over or under supply the ordered quantity by up to 15 %, or on small quantities by 1 or 2 pieces.
Guarantee	Tools recognised to be defective by DC will be replaced free of charge, but without prejudice.
Complaints	Complaints will be considered only within 15 days after receipt of the goods.
Drawings and sketches	The reproduction or transmission of drawings and other documents to a third party are prohibited. The information (drawings and prints) in our catalogue is for guidance only and is not binding.
Special conditions	In the case of partial or total disruption of our production; we reserve the right to partially or totally cancel our delivery commitments.
Tribunal	All disputes are subject to Swiss Law. The seat of court of law will be Moutier (Switzerland).

DC PROGRAMME OVERVIEW



THREAD CUTTING

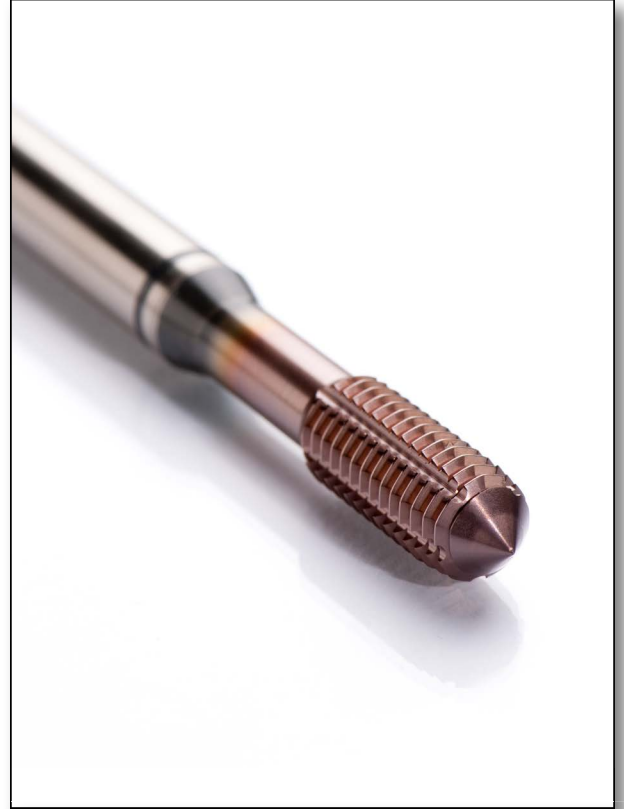

THREAD FORMING

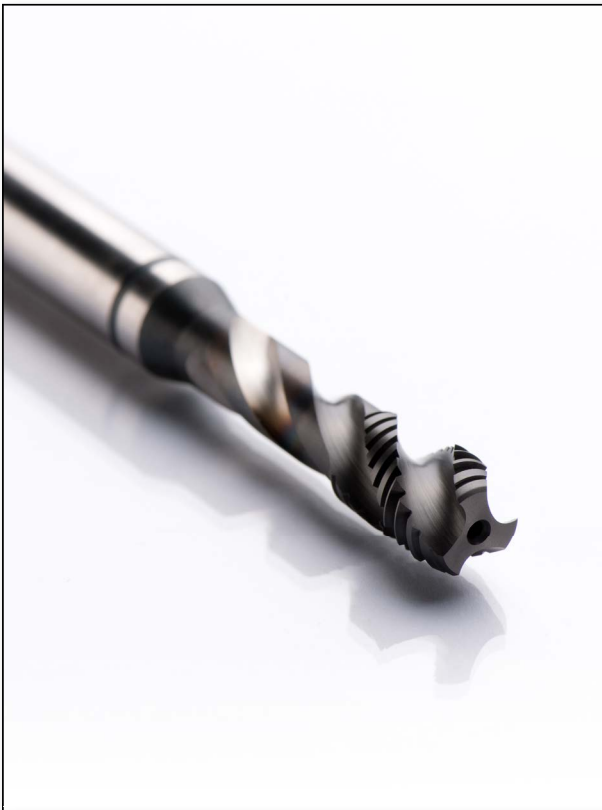

RIGID TAPPING



TAPPING CHUCKS



THREAD WHIRLING

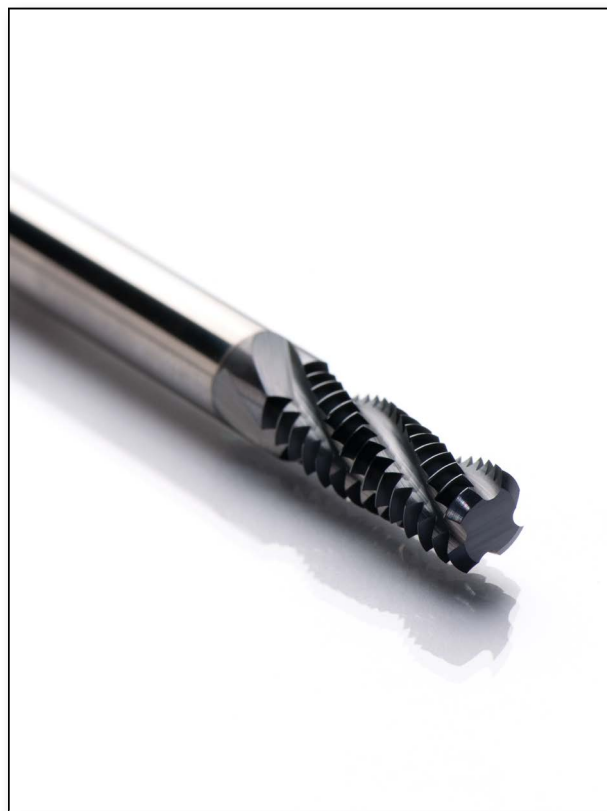

THREAD MILLING



THREAD DIES

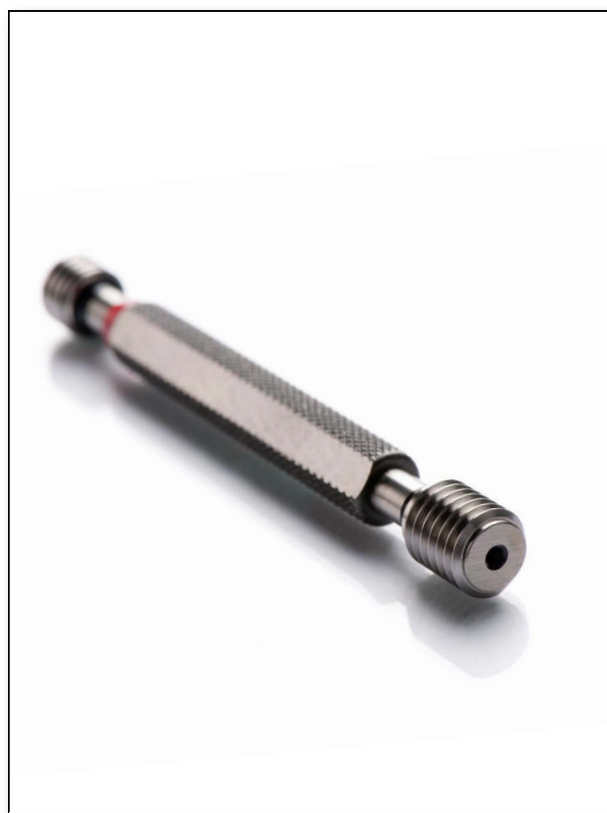

THREAD GAUGES



Schweizerische Eidgenossenschaft
Confédération suisse
Confederazione Svizzera
Confederaziun svizra

Federal Department of Economic Affairs,
Education and Research EAER
State Secretariat for Economic Affairs SECO
Swiss Accreditation Service SAS

Swiss Confederation

Based on the Accreditation and Designation Ordinance dated 17 June 1996 and on the advice of the Federal Accreditation Commission, the Swiss Accreditation Service (SAS) grants to

DC NANO TOOLS SA
Métrologie
Grand-rue 19
2735 Malleray



Period of accreditation:
06.01.2021 until 05.01.2026
(1st accreditation: 06.01.2016)

the accreditation as

Calibration laboratory for Length

International standard: ISO/IEC 17025:2017
Swiss standard: SN EN ISO/IEC 17025:2018

3003 Berne, 17.11.2020
Swiss Accreditation Service SAS

Head of SAS
Konrad Flück

SAS is a signatory of the multilateral agreements of the European co-operation for Accreditation (EA) for the fields of testing, calibration, inspection and certification of management systems, certification of personnel and certification of products, processes and services, of the International Accreditation Forum (IAF) for the fields of certification of management systems and certification of products, processes and services and of the International Laboratory Accreditation Cooperation (ILAC) for the fields of testing and calibration.

Certificate of the Swiss Private Sector Energy Agency

Voluntary Climate Protection and Energy Efficiency

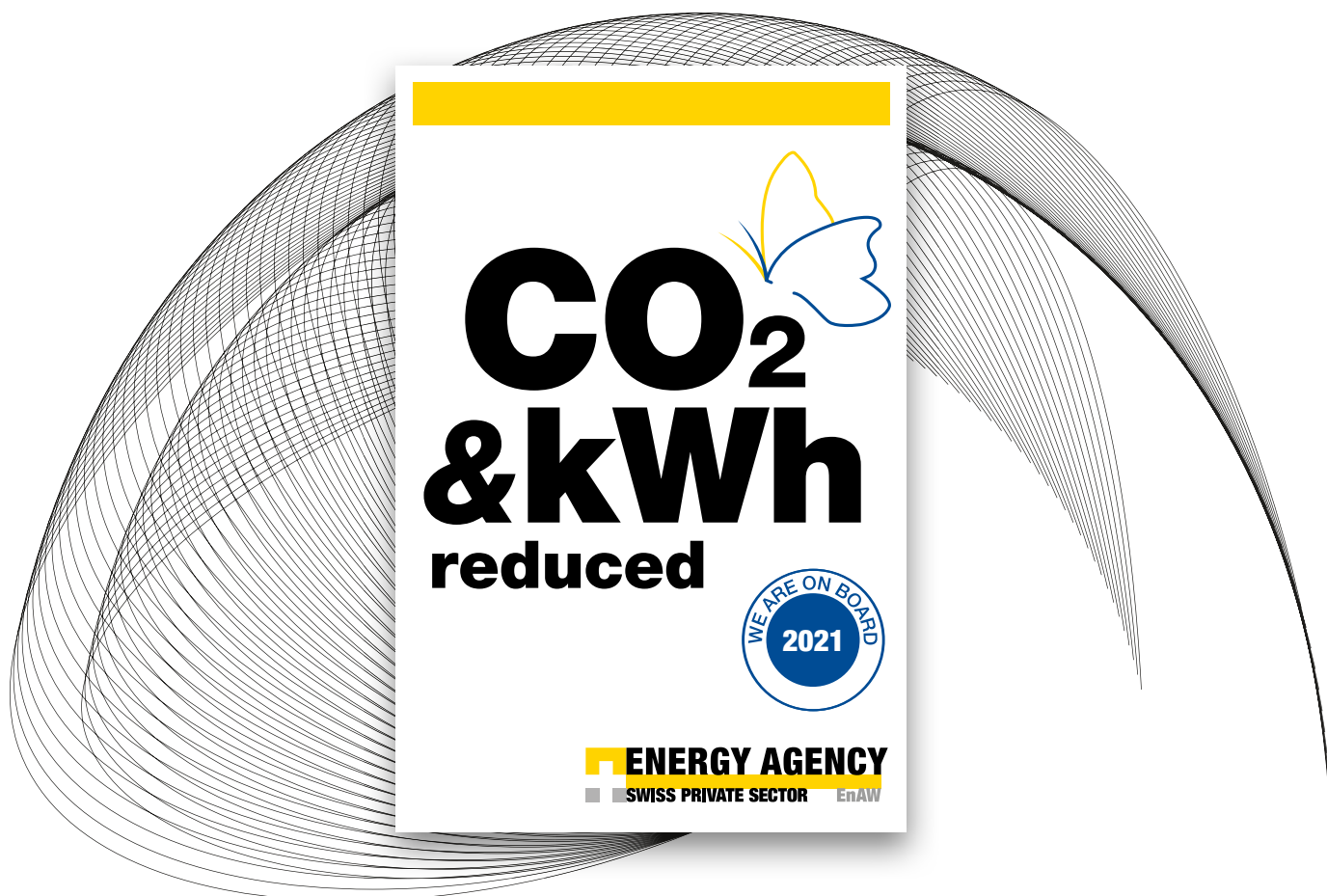

DC Swiss SA

DC Swiss SA is convinced of the need to stand up for sustainable climate protection. By voluntarily declaring its adherence to the Swiss Private Sector Energy Agency programme, DC Swiss SA commits to actively reducing CO₂ emissions and optimizing energy efficiency. The Swiss Federal Government, cantons and private sector partners honor the target agreement.

Dr. Jacqueline Jakob
Swiss Private Sector Energy Agency

1st January 2021

Martin Kernen
Swiss Private Sector Energy Agency

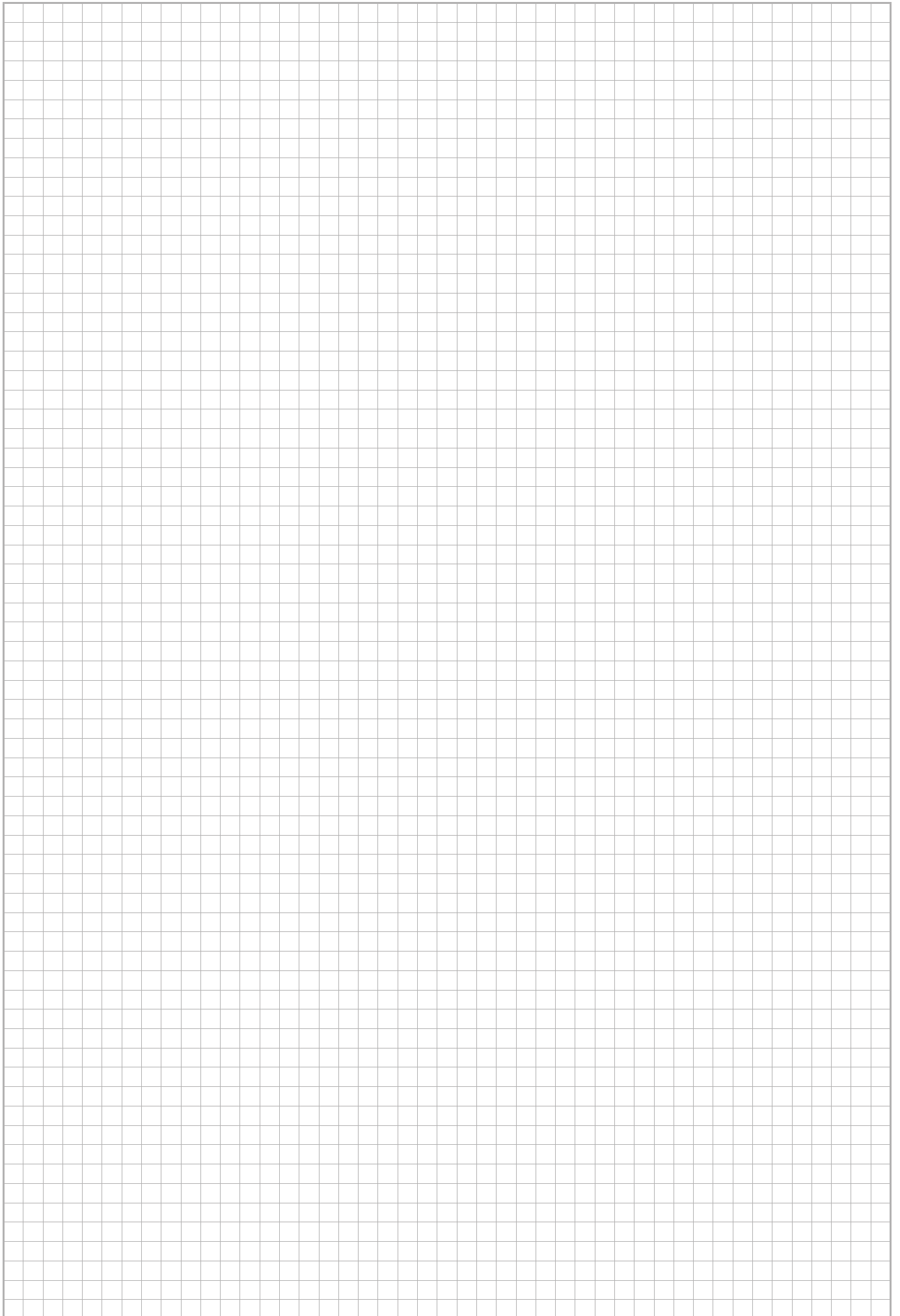

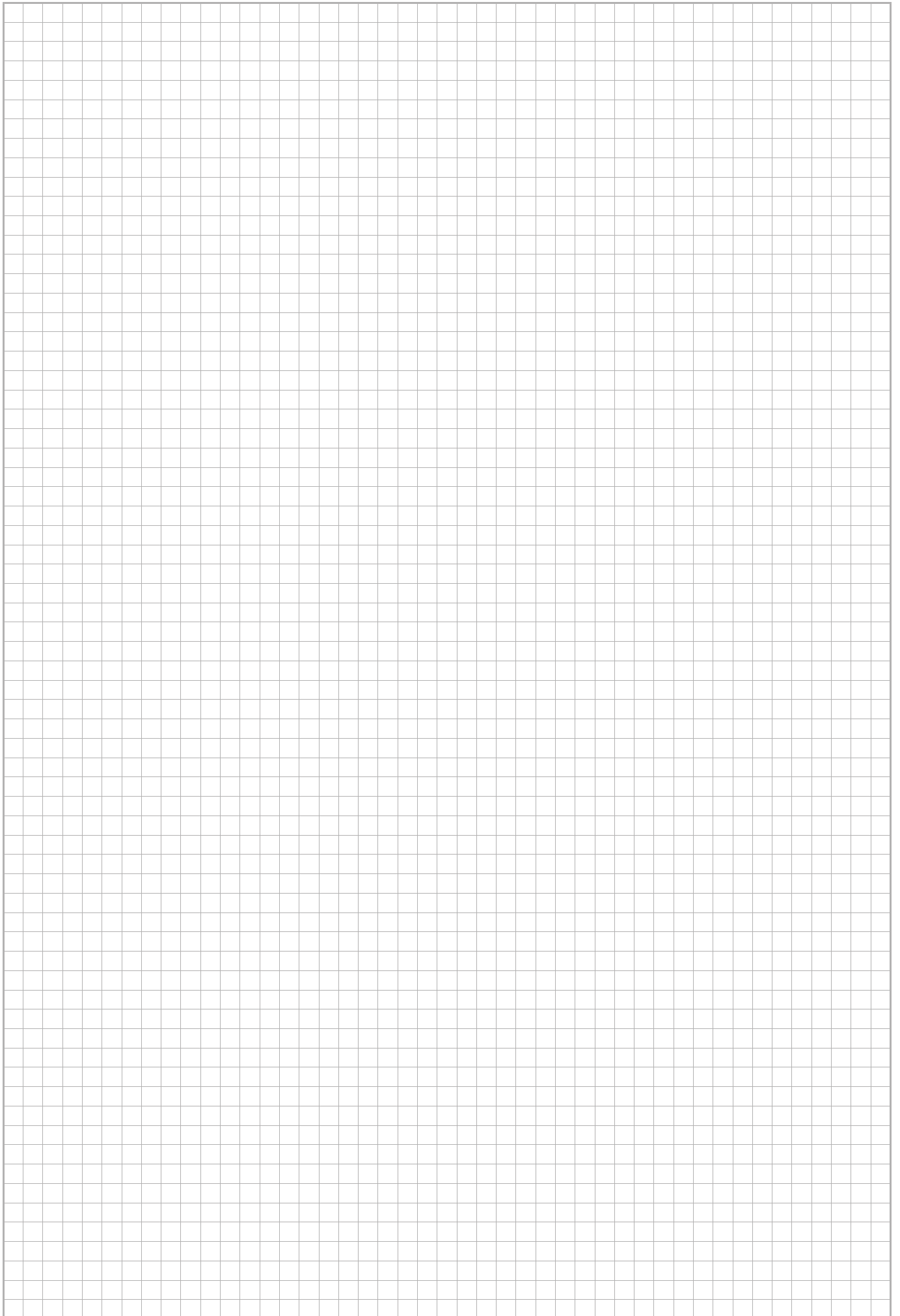

SRT 520 DC SYNCHRO

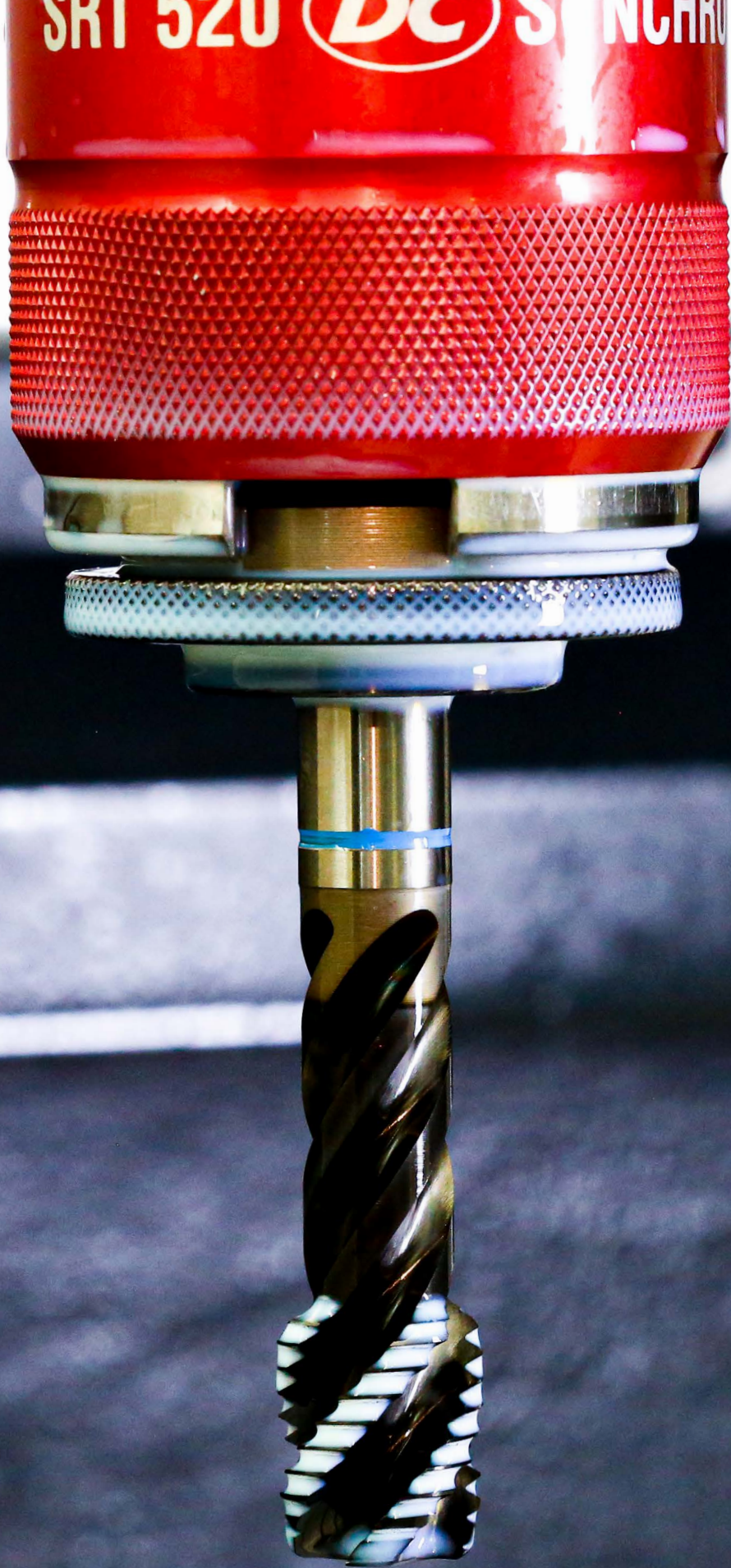



DC SWISS SA
Grand-Rue 19
CH-2735 Malleray
Tel. + 41 32 491 63 63
info@dcswiss.ch



DC Nano Tools SA
Grand-Rue 19
CH-2735 Malleray
Tel. + 41 32 491 63 63
info@dcswiss.ch

DC Swiss GmbH
Graseggerstrasse 125
DE-50737 Köln
Tel. + 49 221 995 532 0
info@dcswiss.de

DC Swiss s.r.l
Via Canova 10
IT-20017 Rho
Tel. + 39 02 669 40 41
info@dcswiss.it

DC Swiss UK Ltd
9 Orgreave Road
GB-Sheffield S13 9LQ
Tel. + 44 114 293 90 13
info@dcswiss.co.uk

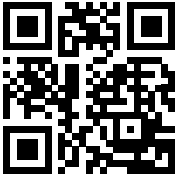

dcswiss.com



ПРЕДУПРЕЖДЕНИЕ

Резьбонарезные инструменты могут сломаться как по причине технического характера, так и допущенной небрежности и причинить вред здоровью оператора. Всегда соблюдайте правила техники безопасности, использование очков является обязательным.

Заточка инструмента образует вредные частицы, поэтому должна выполняться только в соответствии с жесткими стандартами техники безопасности.

WARNING

Thread tools can break or shatter either through technical failure or negligence, and can endanger the health of the operator. Always obey the safety and health regulations, also the wearing of safety glasses is compulsory.

The grinding of threading tools causes hazardous particles, and must be performed only under most rigorous safety standards.

Мы сделали все возможное для того чтобы содержащаяся информация (чертежи, рисунки, технические данные) были верными. Однако мы не несем ответственности за допущенные ошибки и опечатки.

Воспроизведение чертежей и других документов, а также их передача третьим сторонам запрещены.

We have made every effort to ensure that the information (drawings, prints, technical data) given is correct. However, we do not assume any responsibility for any errors, omissions or subsequent changes.

The reproduction of drawings and other documents and their transmission to a third party is prohibited.

Публикация этого каталога отменяет и заменяет все предыдущие издания (кроме каталога ТМ.1)!

The publication of this catalogue renders all previous editions obsolete (exception: catalogue TM.1)!

Translated, proofread and validated by our Russian agent.

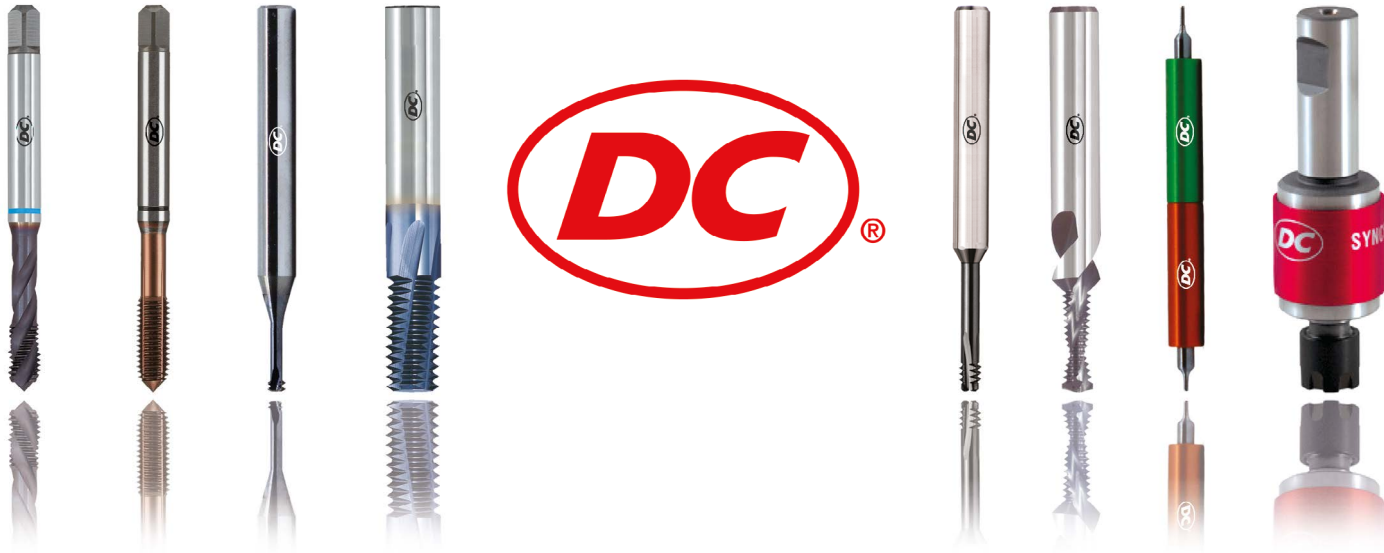

DC SWISS SA

Grand-Rue 19
CH-2735 Malleray
Tel. + 41 32 491 63 63
info@dcswiss.ch

DC Nano Tools SA

Grand-Rue 19
CH-2735 Malleray
Tel. + 41 32 491 63 63
info@dcswiss.ch



DC Swiss GmbH

Graseggerstrasse 125
DE-50737 Köln
Tel. + 49 221 995 532 0
info@dcswiss.de

DC Swiss s.r.l

Via Canova 10
IT-20017 Rho
Tel. + 39 02 669 40 41
info@dcswiss.it

DC Swiss UK Ltd

9 Orgreave Road
GB-Sheffield S13 9LQ
Tel. + 44 114 293 90 13
info@dcswiss.co.uk